



Operating instructions  
IO-Link master with Powerlink interface

**GB**

**AL1370**

## Contents



1	Preliminary note	4
1.1	Symbols used	4
1.2	Warnings used	4
1.3	Change history	4
2	Safety instructions	5
2.1	Cyber security	5
2.2	Safety symbols on the unit	5
3	Intended use	6
4	Function	7
4.1	IO-Link	7
4.1.1	IO-Link supply	7
4.2	Parameter setting	7
4.3	Powerlink	7
4.4	ifm IoT Core	7
4.5	Visual indication	8
4.6	Digital inputs	8
5	Installation	9
5.1	Install device	9
6	Electrical connection	10
6.1	Overview	10
6.2	General wiring information	10
6.2.1	General notes on wiring	10
6.3	Fieldbus ports	11
6.4	IoT port	11
6.5	IO-Link ports (Class A)	11
6.5.1	Connecting IO-Link devices (Class A)	12
6.5.2	Connecting IO-Link devices (Class B)	12
6.6	Ground connection	12
6.7	Voltage supply	13
7	Operating and display elements	14
7.1	LEDs	14
7.1.1	Status	14
7.1.2	Ethernet	14
7.1.3	Voltage supply	15
7.1.4	IoT	15
7.1.5	IO-Link ports (Class A)	15
8	Set-up	16
9	Settings	17
9.1	Configuration tools	17
9.1.1	Supported configuration tools	17
9.1.2	Getting started	17
9.1.3	IoT interface	17
9.1.4	Fieldbus interface	19
9.1.5	Ports	20
9.1.6	Info	21
9.1.7	Firmware	21
9.1.8	IO-Link devices	22
9.2	ifm IoT Core	23
9.2.1	ifm IoT Core: General information	23
9.2.2	Getting started	25
9.2.3	General functions	26
9.2.4	IoT	30
9.2.5	Fieldbus	33
9.2.6	Ports	34
9.2.7	IO-Link devices	39
9.2.8	Gateway	41

9.2.9	Notifications	42
9.2.10	WebSocket support	47
9.2.11	MQTT support	48
9.2.12	ifm IoT Core Visualizer	53
9.3	Powerlink	59
9.3.1	General information	59
9.3.2	Installing the XDD file	59
9.3.3	Gateway	59
9.3.4	Ports	60
9.3.5	IO-Link devices	61
9.3.6	Process data	64
9.3.7	Events	67
10	Maintenance, repair and disposal	68
10.1	Cleaning the housing surface	68
11	Appendix	69
11.1	ifm IoT Core	69
11.1.1	Profiles	69
11.1.2	Types	69
11.1.3	Services	69
11.2	Powerlink	78
11.2.1	Object directory	78

# 1 Preliminary note

You will find instructions, technical data, approvals and further information using the QR code on the unit / packaging or at [www.ifm.com](http://www.ifm.com).

## 1.1 Symbols used

- ✓ Requirement
- ▶ Instructions
- ▷ Reaction, result
- [...] Designation of keys, buttons or indications
- Cross-reference
-  Important note  
Non-compliance may result in malfunction or interference.
-  Information  
Supplementary note

## 1.2 Warnings used

	<b>ATTENTION</b> Warning of damage to property
--	---

	<b>CAUTION</b> Warning of personal injury ▷ Slight reversible injuries may result.
---	--

	<b>WARNING</b> Warning of serious personal injury ▷ Death or serious irreversible injuries may result.
---	--

## 1.3 Change history

Version	Subject	Date
00	New creation of the document	01 / 2021

## 2 Safety instructions

- The unit described is a subcomponent for integration into a system.
  - The system architect is responsible for the safety of the system.
  - The system creator undertakes to perform a risk assessment and to create documentation in accordance with legal and normative requirements to be provided to the operator and user of the system. This documentation must contain all necessary information and safety instructions for the operator, the user and, if applicable, for any service personnel authorised by the architect of the system.
- Read this document before setting up the product and keep it during the entire service life.
- The product must be suitable for the corresponding applications and environmental conditions without any restrictions.
- Only use the product for its intended purpose (→ Intended use).
- If the operating instructions or the technical data are not adhered to, personal injury and/or damage to property may occur.
- The manufacturer assumes no liability or warranty for any consequences caused by tampering with the product or incorrect use by the operator.
- Installation, electrical connection, set-up, operation and maintenance of the product must be carried out by qualified personnel authorised by the machine operator.
- Protect units and cables against damage.

### 2.1 Cyber security

#### ATTENTION

Device operation in an unprotected network environment.

- ▷ Unauthorised read or write access to data is possible.
- ▷ Unauthorised manipulation of the device function is possible.
- ▶ Restrict access to authorised users (e.g. password-protected access).
- ▶ Choose a safe method to connect with the device (e. g. VPN).
- ▶ Use encrypted data transmission (e. g. https / TLS).

### 2.2 Safety symbols on the unit

 Observe instructions in chapter → Electrical connection!

### **3 Intended use**

The unit may only be used for the following purposes:

- IO-Link master for configuration, management and operation of IO-Link devices
- Gateway between IO-Link devices and a higher-level control system

The device is designed for use outside of a control cabinet.

## 4 Function

### 4.1 IO-Link

The unit offers the following IO-Link functions:

- IO-Link master (IO-Link revision 1.0 and 1.1)
- 4 IO-Link ports (Class A) for connection to IO-Link devices
- Provision of the process data of the connected IO-Link devices for monitoring applications (moneo Suite, LR SMARTOBSERVER, LR Agent)

#### 4.1.1 IO-Link supply

The device offers 4 for IO-Link devices. Every supply provides short circuit monitoring.

The ports X01...X04 are IO-Link ports (Class A).

The device ensures fire protection for connected IO-Link devices by providing an energy-limited circuit at the IO-Link ports (according to IEC 61010-1 and Class 2 according to UL1310).

### 4.2 Parameter setting

The device can be configured with the following options:

- Configuration tools (ifm moneo suite, moneo configure SA, LR DEVICE)
- ifm IoT Core (REST API, ifm IoT Core Visualizer)
- Powerlink projection software

### 4.3 Powerlink

The device offers the following Powerlink functions:

- Device profile: Controlled Node (CN)
- Device description: XDD file
- Supported network protocols: UDP
- Support:
  - Multiplexing
  - Multi ASnd

### 4.4 ifm IoT Core

- Mapping of the data, events and services of the device to an object model (ifm IoT Core)
- Integration of the device in IoT applications
- Access to ifm IoT Core:
  - REST-API
  - Browser-based interface (IoT Core Visualizer)
- Cyber security functions
  - Secure data transmission via encrypted connection (Secure Layer Transport - TLS)
  - Access protection via authentication

- Supported protocols: HTTP(S), TCP, JSON, MQTT, Websockets

## 4.5 Visual indication

The device displays the following indications:

- Status and error indication of the gateway and the system
- Status and activity indication of the Ethernet connection
- Status display of the voltage supply
- Status, error and short circuit/overload indication of the sensor ports

## 4.6 Digital inputs

The ports X01...X04 each have an additional digital input (type 2 according to EN 61131-2). The digital inputs are on pin 2.

The digital inputs are supplied via US. They refer to the potential of US (pin 3).



## 5 Installation

### 5.1 Install device



- ▶ Disconnect the power of the machine before installation.
  - ▶ Use a flat mounting surface for installation.
  - ▶ Please observe the maximum tightening torque.
- ▶ Fasten the module onto the mounting surface using M5 screws and washers (tightening torque: 1.8 Nm).

## 6 Electrical connection

### 6.1 Overview

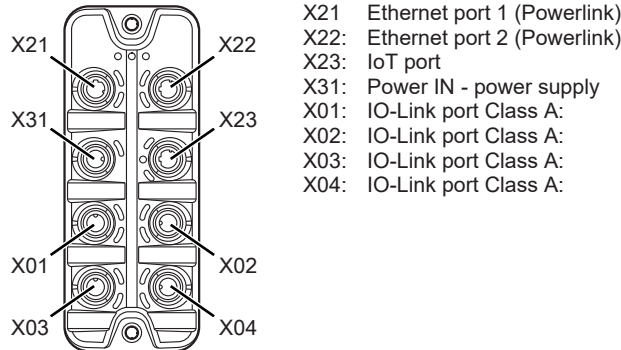

- X21 Ethernet port 1 (Powerlink)
- X22: Ethernet port 2 (Powerlink)
- X23: IoT port
- X31: Power IN - power supply
- X01: IO-Link port Class A:
- X02: IO-Link port Class A:
- X03: IO-Link port Class A:
- X04: IO-Link port Class A:

### 6.2 General wiring information

The unit must be connected by a qualified electrician.

- ▶ Observe the national and international regulations for the installation of electrical equipment.

The unit is only suitable for operation using SELV/PELV voltages.

- ▶ Take information about IO-Link configuration into consideration!

This device contains components that may be damaged or destroyed by electrostatic discharge (ESD).

- ▶ Please observe the required precautions against electrostatic discharge!

By means of basic insulation according to EN61010-1, the circuits are isolated from each other and from device surfaces that could be touched (secondary circuit with V DC maximum, supplied from mains circuit up to 300 V overvoltage category II).

By means of basic insulation according to EN61010-1, the communication interfaces are separated from each other and from device surfaces that could be touched (secondary circuit with V DC maximum, supplied from mains circuit up to 300 V overvoltage category II). They are designed for network environment 0 according to IEC TR62102).

#### 6.2.1 General notes on wiring

The M12 connection parts in the device comply with the ingress resistance requirements of the standard EN 61076-2-101. For compliance with the protection rating, only cables certified according to this standard may be used. The system architect undertakes to ensure the ingress resistance of cables they have cut to length.

- ▶ Carry out the fitting according to the indications of the cable manufacturer. Maximum permissible tightening torque: 0.8 Nm.
- ▶ During installation, place the M12 connector vertically so that the coupling nut will not damage the thread.
- ▶ Provide cables with a strain relief depending on the mounting conditions to avoid excessive strain on the installation points and the M12 connections.
- ▶ Ensure correct fit and proper assembly of the M12 connection parts. If these instructions are not complied with, the specified protection rating cannot be guaranteed.
- ▶ Cover unused sockets with M12 protective caps (art. no.:E73004).

For UL applications:

- ▶ To connect the master and the IO-Link devices, only use UL-certified cables belonging to category CYJV or PVVA with a minimum temperature of 80 °C (75 °C in case of a maximum ambient temperature of 40 °C).

## 6.3 Feldbus ports

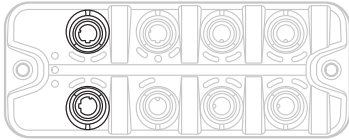

The device is connected to the Powerlinknetwork via the Powerlinkports (e.g. Powerlinkcontrol, additional Powerlinkdevice).

- ▶ Connect the device to the Powerlink network via the X21, X22 ports.
- ▶ For connection, use M12 connectors (with at least protection rating: IP 65 / IP 66 / IP 67).

Wiring:

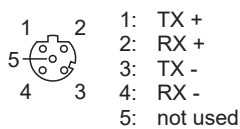

## 6.4 IoT port

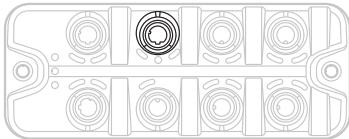

The IoT port connects the device to an IT network (e.g. laptop with configuration tool, monitoring software or IoT-enabled software).

- ▶ Connect the device to the IT network via port X23 .
- ▶ For connection, use M12 connectors (with at least protection rating: IP 65 / IP 66 / IP 67).

Wiring:

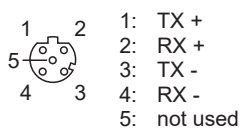

## 6.5 IO-Link ports (Class A)

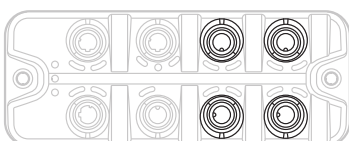

IO-Link devices are connected to the unit via the IO-Link ports (sensors, actuators).

The IO-Link ports meet the requirements of the IO-Link specifications 1.0 to 1.1.2.

Wiring information:

- The connected IO-Link devices must be supplied exclusively via the IO-Link master.
- The ports have an additional digital input (type 2, according to IEC 61131-2).

Wiring:

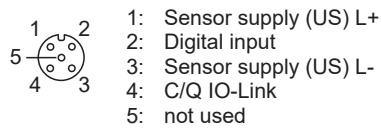

### 6.5.1 Connecting IO-Link devices (Class A)

Wiring information:

- The connected IO-Link devices must be supplied exclusively via the IO-Link master.
- ▶ Connect the IO-Link devices with the ports X01...X04. Maximum cable length per port: 20 m
- ▶ For connection, use M12 connectors (with at least protection rating: IP 65 / IP 66 / IP 67).

### 6.5.2 Connecting IO-Link devices (Class B)

Wiring information:

- The connection of IO-Link devices (Class B) requires the supply with an additional auxiliary voltage UA. Feeding is done with the help of a Y-connection cable (→ accessories).



#### CAUTION

Non-compliance with the electrical separation of the circuits

▷ Risk of fire

▶ Ensure that the external supply UA is electrically separated from the power circuit of the unit by basic insulation (according to IEC 61010-1, secondary current circuit with max. 30 V DC, derived from mains circuit up to 300 V of overvoltage category II).

▶ Ensure that the IO-Link devices and the connection technology support the electrical separation.

- When connecting an IO-Link device (Class B), the additional digital input at pin 2 of the port is not available.
- ▶ Connect IO-Link devices to ports X01...X04 via Y-connection cable.
- ▶ Connect Y cables to the supply voltage 24 V DC (20...30 V SELV/PELV)
- ▶ For connection, use M12 connectors (with at least protection rating: IP 65 / IP 66 / IP 67).

## 6.6 Ground connection

The FE potential is connected to the following points of the device:

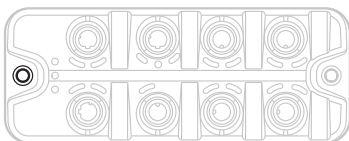

- upper mounting lug of the housing



To ensure the protection of the device against electrical interference and to ensure the safe function of the device, the housing has to be connected to the GND of the installation using the shortest possible route.

- ▶ Ground the unit via the mounting screw of the upper mounting lugs.

## 6.7 Voltage supply

The unit is connected to the power supply via the Power-IN port.

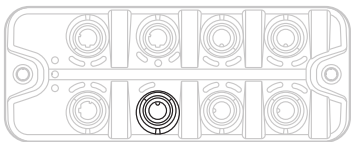

- ▶ Disconnect power!
- ▶ Connect the device via port X31 to 24 V DC (20...30 V SELV/PELV; according to IEC 61010-1, secondary circuit with max. 30 V DC, supplied from main circuit up to 300 V of overvoltage category).
- ▶ Use an L-coded M12 connector (minimum protection type: VARIABLE).



Recommended max. cable length: 25 m.

- ▶ In case of cables that are longer than 25 m, take the voltage drop and the necessary minimum supply voltage of 20 V into consideration!

Wiring:



- 1: + 24 V DC (US)
- 2: not used
- 3: GND (US)
- 4: not used

## 7 Operating and display elements

### 7.1 LEDs

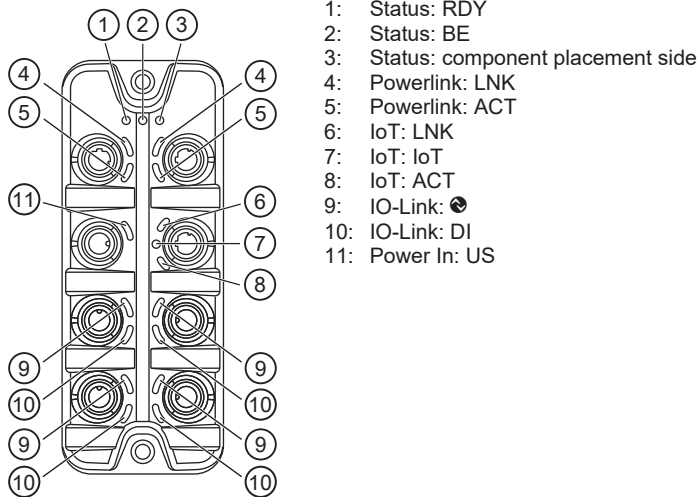

#### 7.1.1 Status

LED	Description	Colour	State	Description
RDY	Gateway status	green	off	Gateway: not active or restarts
			flashes (5 Hz)	Gateway: Error
			flashes (200 ms on, 800 ms off)	Gateway: Firmware update running
			on	Gateway: OK
BE	Network status	red	off	Bus Failure: Error
			on	Bus Failure: no error
component placement side	Powerlink status	green	off	Bus state: Status "NOT_ACTIVE" or "INITIALISATION"
			flashes (10 Hz)	Bus state: Status "BASIC_ETHERNET"
			flashes (200 ms on, 1000 ms off)	Bus state: Status "PRE_OPERATIONAL_1"
			flashes (200 ms on, 200 ms off, 200 ms on, 1000 ms off)	Bus state: Status "PRE_OPERATIONAL_2"
			flashes (200 ms on, 200 ms off, 200 ms on, 200 ms off, 200 ms on, 1000 ms off)	Bus state: Status "READY_TO_OPERATE"
			flashes (2.5 Hz)	Bus state: Status "STOPPED"
			on	Bus state: Status "OPERATIONAL"

#### 7.1.2 Ethernet

LED	Description	Colour	State	Description
LNK	Status of the connection	green	off	no Ethernet connection
			on	Ethernet connection established

LED	Description	Colour	State	Description
ACT	Status of the data transmission	yellow	off	no data transmission
			flashes	Data transmission

### 7.1.3 Voltage supply

LED	Description	Colour	State	Description
US	Status of the voltage supply	green	off	no supply voltage is applied or the applied voltage is too low
			on	Supply voltage applied

### 7.1.4 IoT

LED	Description	Colour	State	Description
LNK	Status of the connection	green	off	no Ethernet connection
			on	Ethernet connection established
ACT	Status of the data transmission	yellow	off	no data transmission
			flashes	Data transmission
IoT	Device identification	green	flashes	Device identification active

### 7.1.5 IO-Link ports (Class A)

LED	Description	Colour	State	Description
☉	Status of the IO-Link port	yellow	off	Port mode DI / DO: pin 4 (C/Q) = OFF
			on	Port mode DI / DO: Pin 4 (C/Q) = ON
		green	flashes (1 Hz)	Port mode IO-Link: no IO-Link device found
			flashes (5 Hz)	Port mode IO-Link: Status "PREOPERATE"
			on	Port mode IO-Link: Status "OPERATE"
		red	flashes (1.2 Hz)	Port configuration error or short circuit / overload on US
on	Transmission error			
DI	Status of the digital input (pin 2)	yellow	off	Digital input: Pin 2 = OFF
			flashes (5 Hz)	Digital input: Pin 2 = ON

## 8 Set-up

- ▶ Install the unit correctly.
- ▶ Establish a correct electrical connection with the device.
- ▷ Once connected to the supply voltage, the unit will start.
- ▷ The LEDs show status and error conditions.
- ▷ The unit is ready for operation.
- ▷ The device can be configured.



## 9 Settings

### 9.1 Configuration tools

#### 9.1.1 Supported configuration tools

The device can be configured with the following configuration tools:

- LR DEVICE
  - ifm moneo suite
  - ifm moneo configure (SA)
- ▶ Install the required configuration tool.
  - ▶ Activate the licences required for operation.
  - ▷ The configuration tool can be used to set the parameters of the unit.

#### 9.1.2 Getting started

Requirements:

- ✓ The configuration tool is correctly installed on the laptop / PC.
- ✓ The laptop / PC is connected to the IoT port of the unit.
- ▶ Start the configuration tool.
- ▶ Scan the network for devices.
  - ▷ The configuration tool recognises the unit.
- ▶ Optional: Adapt the IP settings of the device.
- ▷ The configuration tool can access IO-Link masters and the connected IO-Link devices.

#### 9.1.3 IoT interface

The device is connected to the IT network via the IoT interface.

##### IoT: Configuring IP settings

For communication with the IT network, the IP parameters of the IoT interface must be configured.

- ▶ Select [IoT] menu.

Parameter	Description	Value range	Access
DHCP	Enable / disable the DHCP client	<ul style="list-style-type: none"> <li>• Static IP: DHCP client disabled IP parameters are set by the user</li> <li>• DHCP DHCP client enabled; IP parameters are set by the network's DHCP server.</li> </ul>	rw <sup>1</sup>
IP address	IP address of the IoT interface	e.g. 192.168.100.1 (default)	rw <sup>2</sup>
Subnet mask	Subnet mask of the Ethernet network	e.g. 255.255.255.0 (default)	rw <sup>2</sup>
Default gateway IP address	IP address of the network gateway	e.g. 0.0.0.0 (default)	rw <sup>2</sup>
MAC address	MAC address of the IoT interface		ro <sup>3</sup>

<sup>1</sup> read and write

<sup>2</sup> read and write; can only be changed if DHCP client is enabled

<sup>3</sup> read only

- ▶ Save the changes on the device.

## IoT: Configuring security mode

The unit provides a security mode. The security mode makes it possible to protect access to IO-Link masters and connected IO-Link devices from the IT network. When security mode is activated, the following restrictions apply:

- Access only by authentication (password protection)
- Access only via encrypted connection (TLS - Transport Layer Security)



The security mode only protects access and data transmission via the IoT interface.

The user name `administrator` cannot be changed.

The security mode can be enabled without setting the password at the same time. The next time the unit is accessed, the configuration tool requires the password to be set.

After entering the correct password, the user has unrestricted access to the IO-Link master and the connected IO-Link devices. The password is requested again when the current configuration tool session has ended (e.g. after a restart).

To configure the security mode:

- ▶ Select [IoT] menu.

Parameter	Description	Value range	Access
Security mode HTTPS	Enabling / disabling security mode	<ul style="list-style-type: none"> <li>• Disabled: Security mode disabled</li> <li>• Enabled: Security mode enabled</li> </ul>	rw <sup>1</sup>
Security password	Password for authentication Note: The set password is not displayed.		wo <sup>2</sup>

<sup>1</sup> read and write

<sup>2</sup> write only

- ▶ Save the changes on the device.

## IoT: Configuring access rights

The access rights define which control instance may read or write the parameters, process data and event / diagnostic messages.

- ▶ Select [IoT] menu.

Parameter	Description	Value range	Access
Access Rights	Access rights on the IO-Link master	<ul style="list-style-type: none"> <li>• Fieldbus + IoT (default):               <ul style="list-style-type: none"> <li>– Fieldbus and ifm IoT Core have read and write access rights to parameters and process data</li> <li>– Fieldbus and ifm IoT Core have read access rights to events/alarms</li> </ul> </li> <li>• Fieldbus + IoT (read only):               <ul style="list-style-type: none"> <li>– Fieldbus has read and write access rights to parameters and process data</li> <li>– Fieldbus has read access rights to events/alarms</li> <li>– ifm IoT Core only has read access rights to parameters, process data and events/alarms</li> </ul> </li> <li>• IoT only:               <ul style="list-style-type: none"> <li>– ifm IoT Core has read and write access rights to parameters and process data</li> <li>– IoT has read access rights to events/alarms</li> <li>– Fieldbus has no access rights</li> </ul> </li> </ul>	rw <sup>1</sup>

<sup>1</sup> read and write

- ▶ Save the changes on the device.

## IoT: Configuring the interface to the monitoring software

For optional transmission of process data to monitoring software moneo, LR AGENT or LR SMARTOBSERVER, the interface must be configured accordingly.

- Select [IoT] menu.

Parameter	Description	Value range	Access
IP address Moneo, LR Agent or SMARTOBSERVER	IP address of moneo, LR AGENT or LR SMARTOBSERVER	<ul style="list-style-type: none"> <li>• 0.0.0.0</li> <li>...</li> <li>• 255.255.255.255 (default)</li> </ul>	rw <sup>1</sup>
Port Moneo, LR Agent or SMARTOBSERVER	Number of the moneo port, LR AGENT or LR SMARTOBSERVER to which the process data is sent	<ul style="list-style-type: none"> <li>• 0</li> <li>...</li> <li>• 35100 (default)</li> <li>...</li> <li>• 65535</li> </ul>	rw <sup>1</sup>
Interval Moneo, LR Agent or SMARTOBSERVER	Cycle time for the transfer of the process data to moneo, LR AGENT or LR SMARTOBSERVER (value in ms)	<ul style="list-style-type: none"> <li>• Off: no transmission(default)</li> <li>• 500: 500 ms</li> <li>...</li> <li>• 2147483647: 2147483647 ms</li> </ul>	rw <sup>1</sup>
Application tag	Source identifier of the IO-Link master in the structure of the LR AGENT or LR SMARTOBSERVER (String32)	AL1370 (default)	rw <sup>1</sup>

<sup>1</sup> read and write

- Save the changes on the device.

 After changing the parameters [IP address Moneo, LR Agent or SMARTOBSERVER] or [Application Tag], it may take up to 20 seconds until the device will establish a TCP connection again.

To prevent the delay:

- Restart the device.

### 9.1.4 Fieldbus interface

#### Fieldbus: Configuring the interface

- Select [Fieldbus] menu.

Parameter	Description	Value range	Access
IP address	IP address of the fieldbus interface	e.g. 192168100139	ro <sup>1</sup>
Subnet mask	Subnet mask of the fieldbus network	e.g. 255.255.255.0	ro <sup>1</sup>
Default gateway IP address	IP address of the network gateway	e.g. 192168100254	ro <sup>1</sup>
Host name	Powerlink Hostname	e.g. AL1x7x	rw <sup>2</sup>
MAC address	MAC address of the fieldbus interface of the IO-Link master	e.g. 00:02:01:0f:C8:8F	ro <sup>1</sup>
Fieldbus firmware	Fieldbus firmware of the IO-Link master	e.g.	ro <sup>1</sup>
nodeID	Powerlink node identifier of the unit	<ul style="list-style-type: none"> <li>• 1: 1 (default)</li> <li>...</li> <li>• 239: 239</li> </ul>	rw <sup>2</sup>
installationLocation	Installation location of the unit	e.g. Plant3	rw <sup>2</sup>

<sup>1</sup> read only

<sup>2</sup> read and write

- Save the changes on the device.



## 9.1.5 Ports

### Ports: Setting the data transmission to the monitoring software

- ▶ Select the [Port n] menu (n: 1...4).

Parameter	Description	Value range	Access
Port n: Transmission to Moneo, LR Agent or SMARTOBSERVER	Enable / disable transmission of the process data of the connected sensors to moneo, LR AGENT or LR SMARTOBSERVER	<ul style="list-style-type: none"> <li>• Disabled: Process data not transferred</li> <li>• Enabled: Process data transmitted</li> </ul>	rw <sup>1</sup>

<sup>1</sup> read and write

- ▶ Save the changes on the device.

### Ports: Setting the operating mode Pin 4 (US)

- ▶ Select the [Port n] menu (n: 1...4).

Parameter	Description	Value range	Access
Port n: Mode Pin4 US	Operating mode of Pin 4 (C/Q) of the port	<ul style="list-style-type: none"> <li>• Disabled: Port disabled</li> <li>• DI: Digital input</li> <li>• DO: Digital output</li> <li>• IO-Link: IO-Link process data</li> </ul>	rw <sup>1</sup>

<sup>1</sup> read and write

- ▶ Save the changes on the device.

### Ports: Setting validation and data storage

- ▶ Select the [Port n] menu (n: 1...4).

Parameter	Description	Value range	Access
Port n: Validation / Data Storage	Validation of the connected IO-Link devices and automatic recovery of the parameter sets of the IO-Link device	<ul style="list-style-type: none"> <li>• No check and clear: <ul style="list-style-type: none"> <li>– No compatibility check</li> <li>– No backup / restore of parameter values</li> </ul> </li> <li>• Type compatible V1.0 device: <ul style="list-style-type: none"> <li>– Compatibility check on IO-Link standard V1.0</li> <li>– No backup / restore of parameter values</li> </ul> </li> <li>• Type compatible V1.1 device <ul style="list-style-type: none"> <li>– Compatibility check on IO-Link standard V1.1</li> <li>– No backup / restore of parameter values</li> </ul> </li> <li>• Type compatible V1.1 device with Backup + Restore: <ul style="list-style-type: none"> <li>– Compatibility check on IO-Link standard V1.1</li> <li>– Automatic storage of the parameter values; Changes are saved</li> <li>– Automatic recovery of the parameter values when connecting an identical IO-Link device with factory settings</li> </ul> </li> <li>• Type compatible V1.1 device with Restore <ul style="list-style-type: none"> <li>– Compatibility check on IO-Link standard V1.1</li> <li>– No storage of the parameter values</li> <li>– Automatic recovery of the parameter values when connecting an identical IO-Link device with factory settings</li> </ul> </li> </ul>	rw <sup>1</sup>

Parameter	Description	Value range	Access
Port n: Vendor ID	Vendor ID of the IO-Link device to be validated against	e.g. 310: ifm electronic gmbh	rw <sup>1</sup>
Port n: Device ID	Device ID of the IO-Link device to be validated against	e.g. 1129: TCC501 (ifm temperature sensor)	rw <sup>1</sup>

<sup>1</sup> read and write; Parameter only available if operating mode pin 4 (US) = IO-Link and IO-Link device is connected to port

► Save the changes on the device.

### Ports: Setting the cycle time

► Select the [Port n] menu (n: 1...4).

Parameter	Description	Value range	Access
Port n: Cycle time actual	Current cycle time between the IO-Link master and the IO-Link device (value in $\mu$ s)	<ul style="list-style-type: none"> <li>• 0: best possible cycle time</li> <li>...</li> <li>• 132800: 132800 <math>\mu</math>s</li> </ul>	ro <sup>1</sup>
Port n: Cycle time preset	Cycle time between the IO-Link master and the IO-Link device (value in $\mu$ s)	<ul style="list-style-type: none"> <li>• 0: The IO-Link master automatically sets the best possible cycle time</li> <li>• 1: 1 <math>\mu</math>s</li> <li>...</li> <li>• 132800: 132800 <math>\mu</math>s</li> </ul>	rw <sup>2</sup>
Port n: Bit rate	Transmission rate between the IO-Link master and the IO-Link device	<ul style="list-style-type: none"> <li>• COM1: 4.8 kbaud</li> <li>• COM2: 38-4 kbaud</li> <li>• COM3: 230.4kbaud</li> </ul>	ro <sup>1</sup>

<sup>1</sup> read only; Parameter only available if operating mode pin 4 (US) = IO-Link and IO-Link device is connected to port

<sup>2</sup> read and write; Parameter only available if operating mode pin 4 (US) = IO-Link and IO-Link device is connected to port

► Save the changes on the device.

## 9.1.6 Info

### Info: Displaying the device information

► Select [Info] menu.

Parameter	Description	Value range	Access
Product code	Article number	AL1370	ro <sup>1</sup>
Device family	Device family	IO-Link master	ro <sup>1</sup>
Vendor	Manufacturer	ifm electronic gmbh	ro <sup>1</sup>
SW revision	Firmware version	e.g. AL1x7x_cn_pl_v3.3.40	ro <sup>1</sup>
HW revision	Hardware revision	e.g. AB	ro <sup>1</sup>
Bootloader revision	Bootloader version	e.g. AL1xxx_bl_f7_v1.2.0	ro <sup>1</sup>
Serial number	Serial number	e.g. 0002043100003	ro <sup>1</sup>
Fieldbus type	Fieldbus	Powerlink	ro <sup>1</sup>

<sup>1</sup> read only

## 9.1.7 Firmware

### Firmware: Showing the firmware version

► Select [Firmware] menu.

Parameter	Description	Value range	Access
Version	Firmware version	e.g. AL1x7x_cn_pl_v3.3.40	ro <sup>1</sup>

<sup>1</sup> read only

### **Firmware: Resetting the device**

Only available with LR DEVICE

- ▶ Select [Firmware] menu.
- ▶ Click on [Factory Reset] .
- ▷ The device will be reset to the factory settings.
- ▷ All parameters are set to their default values.

### **Firmware: Rebooting the device**

Only available with LR DEVICE

- ▶ Select [Firmware] menu.
- ▶ Click on [Reboot].
- ▷ The device will be restarted.
- ▷ All set parameter values will be retained.

## **9.1.8 IO-Link devices**

The unit supports access to connected IO-Link devices (sensors, actuators) with the configuration tools.

Requirements:

- ✓ The IO-Link master is correctly mounted and electrically connected.
- ✓ The IO-Link device is correctly connected to the IO-Link port of the device.
- ✓ The configuration tool is connected to network.
- ✓ Operating mode Pin 4 (US) of the IO-Link port is "IO-Link" (→ Ports: Setting the operating mode Pin 4 (US) □ 20).
- ✓ IoT has read and write rights to the device (→ IoT: Configuring access rights □ 18).
- ▶ Update the IODD library of the configuration tool.
- ▶ Scan the network for devices.
  - ▷ The configuration tool detects the IO-Link master.
- ▶ Click on the IO-Link master found.
  - ▷ The configuration tool displays a detailed view of the IO-Link master.
  - ▷ The configuration tool recognises the connected IO-Link device.
- ▶ Click on the IO-Link device.
  - ▷ A detailed view of the IO-Link device appears.
  - ▷ The detailed view shows the current parameter values of the IO-Link device.
- ▶ Configure the IO-Link device.
- ▶ Store the changed configuration of the IO-Link device.

## 9.2 ifm IoT Core

### 9.2.1 ifm IoT Core: General information

The device has the ifm IoT Core. The ifm IoT Core represents the functionality of a device. Each device is represented by a number of objects, services and events. The elements of the ifm IoT Core are arranged in a JSON object in a hierarchical tree structure. The ifm IoT Core makes these elements available to the outside world via standard interfaces. This allows the user and other devices to access data (parameters, process data, events) and functions (services) of the ifm IoT Core.

#### Accessing the ifm IoT Core

An element of the ifm IoT Core is accessed via its address (e.g. `root/port1/pin2`). The address is composed of the path leading to the element (`root/port1`) and the identifier of the element (`pin2`).

The user can access the ifm IoT Core via HTTP requests. The following methods are supported:

#### GET method

Access: reading

Syntax of the request:

```
http://ip/datapoint/service
```

Parameter	Description
ip	IP address of the IoT interface
data_point	Data point which is to be accessed
service	Service

Syntax of the response:

```
{
  "cid":id,
  "data":{"value":resp_data},
  "code":diag_code
}
```

Parameter	Description
id	Correlation ID for the assignment of request and reply
resp_data	Value of the data point; depending on the data type of the data point
diag_code	Diagnostic code Diagnostic codes (→ 25)

#### Example: GET request

- Request:

```
http://192.168.0.250/devicetag/applicationtag/getdata
```

- Response:

```
{
  "cid":-1,
  "data":{"value":"AL1370"},
  "code":200
}
```

## POST method

Access: reading, writing

Syntax of the request:

```
{
  "code": "code_id",
  "cid": id,
  "adr": "data_point/service",
  "data": {req_data},
  "auth": {"user": "usr_id", "passwd": "password"}
}
```

Field	Parameter	Description
code	code_id	Service class <ul style="list-style-type: none"> <li>request: Request</li> <li>transaction: Transaction</li> <li>event: event</li> </ul>
cid	id	Correlation ID for the assignment in pairs of request and return identifier freely assignable by the user
adr	data_point	Data point of the element tree to be accessed
	service	service to be performed (→ Services □ 69)
data <sup>1</sup>	req_data	Data sent to the ifm IoT Core (e.g. new values); Syntax depending on the service
auth <sup>2</sup>	usr_id	User name (BASE64 coded); Default: administrator
	password	Passwort (BASE64-coded)

<sup>1</sup> optional; only required for services that send data to the ifm IoT Core (e.g. setdata)

<sup>2</sup> optional; only required if security mode is activated

Syntax of the response:

```
{
  "cid": id,
  "data": {resp_data},
  "code": diag_code
}
```

Field	Parameter	Description
cid	id	Correlation ID for the assignment of request and return (→ Request)
data <sup>1</sup>	resp_data	Values returned by the ifm IoT Core; Syntax depending on the service
code	diag_code	Diagnostic code (→ Diagnostic codes □ 25)

<sup>1</sup> optional; only available for services that receive data from the ifm IoT Core (e.g. getdata)

Device-specific error codes are output in the event of faulty acyclic access to connected IO-Link devices.

Syntax of the response in the event of incorrect access:

```
{
  "cid": id,
  "error": err_code,
  "code": diag_code
}
```

Field	Parameter	Description
cid	id	Correlation ID for the assignment of request and return (→ Request)
error	err_code	device-specific error code (→ IO Device Description (IODD) of the IO-Link device)



Field	Parameter	Description
code	diag_code	Diagnostic code (→ Diagnostic codes <a href="#">□ 25</a> )

### Example: POST request

- Request:

```
{
  "code": "request",
  "cid": -1,
  "adr": "devicetag/applicationtag/getdata"
}
```

- Response:

```
{
  "cid": -1,
  "data": {"value": "VARIABLE_LINK"},
  "code": 200
}
```

GB

### Diagnostic codes

Code	Text	Description
200	OK	Request successfully processed
230	OK but needs reboot	Request successfully processed The IO-Link master must be rebooted
231	OK but block request not finished	Request successfully processed blockwise request, but not finished
233	IP settings (of IoT-Port) have been updated. Application needs to reload device. Wait at least 1 second before reloading the device.	The IP settings have been successfully changed, IO-Link master will be reloaded; wait for at least 1 second
400	Bad request	Invalid request
401	Unauthorized	Non authorised request
403	Forbidden	Forbidden request
500	Internal Server Error	Internal fault; detailed information in the "error" field
503	Service Unavailable	Service not available (e.g. IO-Link port in wrong operating mode; no IO-Link device on IO-Link port)
507	Insufficient Storage	The internal memory for notifications is full (max. 16 kB)
530	The requested data is invalid	Invalid process data
531	IO-Link Error	Error in IO-Link master / IO-Link device; detailed information in the "error" field
532	PLC connected Error	Error when writing data because IO-Link master is still connected to fieldbus PLC

### 9.2.2 Getting started

To register the device description of the VARIABLE\_AL1330:

- ▶ Send the following POST request to the ifm IoT Core:  
{"code": "request", "cid": -1, "adr": "gettree"}
- ▷ ifm IoT Core returns the device description as a structured JSON object.
- ▶ Identify all substructures and the data points contained therein in the tree structure of the JSON object.

- Identify the applicable services for the access to substructures and the data points contained therein.

### 9.2.3 General functions

The device has the type “device” (→ Types □ 69). The following services can be applied to the root element of the device tree:

Service	Description
../gettree	Provide the complete tree or subtree of the device description (JSON)
../getidentity	Read identification information of the device
../getdatamulti	Reading several elements sequentially
../getelementinfo	Reading detailed information of an element
../getsubscriberlist	Print a list of all active notification subscriptions
../querytree	Search device description for specific elements

The following services can be applied to elements of the type `data` depending on its access rights:

Service	Description
../getdata	Reading the value of the element
../setdata	Write the value of the element

#### Example: Reading properties of an element

**Task:** Determine the data type and value range of the `accessrights` parameter.

**Solution:** Read the properties of the element `iotsetup/accessrights` of the `getelementinfo` service. The fields `type` (data type) and `valuation` (range of values) contain the required information.

- Request:

```
{
  "code": "request",
  "cid": 4711,
  "adr": "getelementinfo",
  "data": {"adr": "iotsetup/accessrights"}
}
```

- Response:

```
{
  "cid":4711,
  "data":{
    "identifier":"accessrights",
    "type":"data",
    "uid":null,
    "profiles":["parameter"],
    "format":{
      "type":"enum",
      "namespace":"json",
      "encoding":"integer",
      "valuation":{
        "valuelist":{
          "0":"Fieldbus + IoT",
          "1":"Fieldbus + IoT (read-only)",
          "3":"IoT only"}
        }
      }
    },
    "code":200
  }
}
```

The accessrights parameter has the data type ENUM with the valid values "Fieldbus + IoT", "Fieldbus + IoT (read only)" and "IoT only".

### Example: Outputting the subtree

**Task:** Output all direct sub-elements of the node firmware.

**Solution:** Use the service gettree to output the required subtree (root node: firmware, sub-levels to be shown: 1)

- Request:

```
{
  "code":"request",
  "cid":4711,
  "adr":"gettree",
  "data":{"adr":"firmware","level":1}
}
```

- Response:

```

{
  "cid":4711,
  "data":{
    "identifier":"firmware",
    "type":"structure",
    "profiles":["software","software/uploadablesoftware"],
    "subs":[
      {"identifier":"version","type":"data","profiles":["parameter"],
        "format":{"type":"string","namespace":"json","encoding":"UTF-8"}},
      {"identifier":"type","type":"data",
        "format":{"type":"string","namespace":"json","encoding":"UTF-8"}},
      {"identifier":"install","type":"service"},
      {"identifier":"factoryreset","type":"service"},
      {"identifier":"signal","type":"service"},
      {"identifier":"container","type":"data",
        "format":{"type":"binary","namespace":"json","encoding":"base64"}},
      {"identifier":"reboot","type":"service"}
    ]
  },
  "code":200
}

```

### Example: Changing a parameter value

**Task:** The Application Tag parameter of the unit is to be written with the value "Do not use". The new value is only supposed to be valid until the next reboot of the unit.

**Solution:** Write the new value of the applicationspecifictag element with the setdata service. To keep the new value only until the next restart of the unit, pass on the duration option with the uptime value.

- Request:

```

{
  "code":"request",
  "cid":4711,
  "adr":"/devicetag/applicationtag/setdata",
  "data":{"duration":"uptime","newvalue":"Do not use"}
}

```

- Response:

```

{
  "cid":4711,
  "code":200,
}

```

### Example: Reading several elements sequentially

**Task:** The following current values are to be read by the IO-Link master. Temperature, serial number

**Solution:** Read the current parameter values using the getdatamult (data point temperature service: /processdatamaster/temperature; Data point serial number: /deviceinfo/serialnumber)

- Request:

```
{
  "code": "request",
  "cid": 4711,
  "adr": "/getdatamulti",
  "data": {"datatosend": [
    "/processdatamaster/temperature",
    "/deviceinfo/serialnumber"]
  }
}
```

- Response:

```
{
  "cid": 4711,
  "data": {
    "processdatamaster/temperature": {"code": 200, "data": 44},
    "deviceinfo/serialnumber": {"code": 200, "data": "000174210147"}},
  "code": 200
}
```

### Example: Browsing device description

**Task:** List all elements with the designation "status" and the profile "runcontrol".

**Solution:** Use the service querytree to browse the device description with the parameters "status" (name) and "runcontrol" (profile)

- Request:

```
{
  "cid": 4711,
  "code": "request",
  "adr": "querytree",
  "data": {"profile": "runcontrol", "name": "status"}
}
```

- Response:

```
{
  "cid": 4711,
  "data": {"adrList": [
    "device/connections/mqttConnection/status",
    "device/connections/mqttConnection/mqttCmdChannel/status"]},
  "code": 200
}
```

### DNS support

The ifm IoT Core supports the Domain Name System (DNS) service for the name resolution of IP addresses. The user can use the corresponding host name instead of the concrete IP address in the request. DNS can be used both for addressing the IoT core and for addressing network participants.

### Example: Using DNS support

#### Example 1: gettree

Synonymous requests:

- `http://192.168.23.70:8080/gettree`
- `http://example.org:8080/gettree`

**Example 2:** subscribe

Synonymous requests:

- with IP address:

```
{
  "cid":11,
  "code":10,
  "adr":"setasync/datachanged/subscribe",
  "data":{
    "datatosend":["setasync"],
    "callback":"192.168.23.70:8080/dump"}
}
```

- with host name:

```
{
  "cid":11,
  "code":10,
  "adr":"setasync/datachanged/subscribe",
  "data":{
    "datatosend":["setasync"],
    "callback":"http://example.com:8080/dump"}
}
```

## 9.2.4 IoT

### IoT: Configuring access rights

Substructure: iotsetup

Available data points:

Name	Description	Access
../accessrights	Access rights on the IO-Link master	rw <sup>1</sup>

<sup>1</sup> read and write

### IoT: Configuring IP settings

Substructure: iotsetup/network

Available data points:

Name	Description	Access
../dhcp	Activate / deactivate DHCP mode	rw <sup>1</sup>
../ipaddress	IP address of the IoT interface	rw <sup>1</sup>
../subnetmask	Subnet mask of the network segment	rw <sup>1</sup>
../ipdefaultgateway	IP address of the network gateway	rw <sup>1</sup>

<sup>1</sup> read and write

Applicable services:

Name	Description
../setblock	write all data points of the substructure blockwise

Write the data points of the substructure only with the `setblock` service!

## IoT: Configuring security mode

The unit provides a security mode. The security mode makes it possible to protect access to IO-Link masters and connected IO-Link devices from the IT network. When security mode is activated, the following restrictions apply:

- Access only by authentication (password protection)
- Access only via encrypted connection (TLS - Transport Layer Security)



The security mode only protects access and data transmission via the IoT interface.

- ▷ The user name `administrator` cannot be changed.
- ▷ The set password cannot be read with `getdata`.

The current status of the security mode can be read with the `getidentity` service (→ Service: `getidentity` □ 71).

For the authentication, the user must additionally provide the POST requests with a valid user name and password in the field "auth". The user name and the password are shown as Base64-coded character strings.

The following requests can be done if the security mode is enabled, also without authentication:

- `/getidentity`
- `/deviceinfo/vendor/getdata`
- `/deviceinfo/productcode/getdata`

Substructure: `iotsetup`

Available data points:

Name	Description	Access
<code>../security/securitymode</code>	Enabling / disabling security mode	rw <sup>1</sup>
<code>../security/password</code>	Password for authentication (Base64 coded)	wo <sup>2</sup>

<sup>1</sup> read and write

<sup>2</sup> write only



Valid character set for the Base64 coding / decoding of the password: UTF-8

Online tool for coding / decoding: [www.base64encode.org](http://www.base64encode.org)

### Example: Activating security mode

**Task:** The security mode of the IoT interface is to be activated. The valid password is to be set to "password" (BASE64-coded: `cGFzc3dvcmQ=`).

**Solution:** Activate the security mode via the data point `iotsetup/security/securitymode`. Write the required password to the data point `iotsetup/security/password`.

#### Activating security mode

- Request:

```
{
  "code": "request",
  "cid": -1,
  "adr": "/iotsetup/security/securitymode/setdata",
  "data": {"newvalue": "1"}
}
```

- Response:

```
{
  "cid":-1,
  "code":200
}
```

### Setting the password

- Request:

```
{
  "code":"request",
  "cid":-1,
  "adr":"/iotsetup/security/password/setdata",
  "data":{"newvalue":"cGFzc3dvcmQ="}
}
```

- Response:

```
{
  "cid":-1,
  "code":200
}
```

### Example: Request with authentication

**Task:** The temperature of the IO-Link master is to be read. The security function is enabled (current password: password).

**Solution:** Read the data point processdatamaster/temperature. The request must be sent using https. The user name and the password are transferred as a Base64-coded character string ("administrator" = "YWRtaW5pc3RyYXRvcg==", "password" = "cGFzc3dvcmQ=")

- Request:

```
{
  "code":"request",
  "cid":-1,
  "adr":"processdatamaster/temperature/getdata",
  "auth":{"user":"YWRtaW5pc3RyYXRvcg==","passwd":"cGFzc3dvcmQ="}
}
```

- Response:

```
{
  "cid":-1,
  "data":{"value":37},
  "code":200
}
```

### Example: Resetting the password

**Task:** The existing password is to be reset.

**Solution:** To reset a password, disable the security mode. To disable it, enter the user name and the password (the fields "user" and "passwd").

- Request:



```
{
  "code": "request",
  "cid": -1,
  "adr": "iotsetup/security/securitymode/setdata",
  "data": {"newvalue": 0},
  "auth": {"user": "YWRtaWw5pc3RyYXRvcg==", "passwd": "SW9UNG1mbQ=="}
}
```

- Response:

```
{
  "cid": -1,
  "code": 200
}
```

## IoT: interface to moneo, configuring LR AGENT and LR SMARTOBSERVER

Substructure: iotsetup

Available data points:

Name	Description	Access
../smobip	IP address of moneo, LR AGENT or LR SMARTOBSERVER	rw <sup>1</sup>
../smobport	Number of the moneo port, LR AGENT or LR SMARTOBSERVER to which the process data is sent	rw <sup>1</sup>
../smobinterval	Cycle time for the transfer of the process data to moneo, LR AGENT or LR SMARTOBSERVER (value in ms)	rw <sup>1</sup>

<sup>1</sup> read and write

Substructure: devicetag

Available data points:

Name	Description	Access
../applicationtag	Designation of the IO-Link master in moneo, LR AGENT or LR SMARTOBSERVER	rw <sup>1</sup>

<sup>1</sup> read and write



32 bytes are available on the IO-Link master for storing the applicationtag parameter. If the memory range is exceeded, the IO-Link master will abort the write process and return the diagnostic code 400.

- ▶ When writing the applicationtag parameter, note the different memory requirements of the individual UTF-8 characters (characters 0-127: 1 byte per character; character >127: more than 1 byte per character).

## 9.2.5 Fieldbus

### Fieldbus: Configuring the POWERLINK interface

Substructure: fieldbussetup

Available data points:

Name	Description	Access
../nodeid	Node ID of the IO-Link master in fieldbus project <ul style="list-style-type: none"> <li>• 1: Node ID 1</li> <li>• ...</li> <li>• 239: Node ID 239</li> </ul>	rw <sup>1</sup>
../installationlocation	Designation for place of installation (freely selectable, max. 20 characters)	rw <sup>1</sup>

Name	Description	Access
../connectionstatus	Status of the connection to the <Feldbus> network <ul style="list-style-type: none"> <li>• 0: not connected</li> <li>• 1: connected</li> </ul>	ro <sup>2</sup>
../hostname	Name of the <IO> master in the fieldbus project	rw <sup>1</sup>
../fieldbusfirmware	Firmware version of the IO-Link master	ro <sup>2</sup>
../network/ipaddress	IP address of the fieldbus interface	ro <sup>2</sup>
../network/subnetmask	Subnet mask of the network segment	ro <sup>2</sup>
../network/ipdefaultaddress	IP address of the network gateway	ro <sup>2</sup>
../network/macaddress	MAC address of the fieldbus interface	ro <sup>2</sup>

<sup>1</sup> read and write

<sup>2</sup> read only

## 9.2.6 Ports

### Ports: Setting the operating mode Pin 4 (US)

Substructure: iolinkmaster/port[n] (n: 1...4)

Available data points:

Name	Description	Access
../mode	Operating mode Pin 4 (US) of the port	rw <sup>1</sup>
../mastercycletime_preset	Cycle time of the data transmission on the port (value in µs)	rw <sup>1</sup>
../mastercycletime_actual	current cycle time of the data transmission on the port (value in µs)	ro <sup>2</sup>
../comspeed	Data transfer rate of the port	ro <sup>2</sup>

<sup>1</sup> read and write; can only be changed if no connection to the fieldbus controller is active

<sup>2</sup> read only

### Ports: Configuring the device validation and data storage

Substructure: iolinkmaster/port[n] (n: 1...4)

Name	Description	Access
../validation_datastorage_mode	Behaviour of the port when connecting a new IO_Link device	rw <sup>1</sup>
../validation_vendorid	IO-Link ID of the manufacturer that is to be validated	rw <sup>1</sup>
../validation_deviceid	IO-Link ID of the equipment to be validated	rw <sup>1</sup>
../datastorage	Structure for port data storage	rw <sup>1</sup>
../datastorage/maxsize	Maximum size of the data storage content (in bytes)	ro <sup>2</sup>
../datastorage/chunksize	Size of a data segment (in bytes)	ro <sup>2</sup>
../datastorage/size	Size of the data storage content (in bytes)	ro <sup>2</sup>

<sup>1</sup> read and write; can only be changed if no connection to the fieldbus controller is active

<sup>2</sup> read only

Applicable services:

Name	Description
../validation_useconnecteddevice	Validate the IO-Link device
../datastorage/getblobdata	Reading the content of the data storage area
../datastorage/stream_set	Transfer an individual data segment
../datastorage/start_stream_set	Start sequential transmission of several data segments

### Example: Cloning the data memory of an IO-Link port

Task: The data memory of port 2 of IO-Link master 1 is to be cloned to IO-Link master 2.

Solution: The cloning consists of 2 steps. In the first step, the data memory of the port is read by IO-Link master 1. In the second step, the read data is stored in the data memory of the port of IO-Link master 2.

#### Read data memory

- Read segment size of the data storage (h = number of bytes)

```
{
  "code": "request",
  "cid": -1,
  "adr": "/iolinkmaster/port[2]/datastorage/chunksize/getdata"
}
```

Example: h = 256

- Read total size of the data storage (g = number of bytes)

```
{
  "code": "request",
  "cid": -1,
  "adr": "/iolinkmaster/port[2]/datastorage/size/getdata"
}
```

Example: g = 550

- Calculate the number of reading steps n: n = first integer value for which applies:  $g < n \cdot h$

Example: n = 3, da  $550 < 3 \cdot 256$

- Read the data storage segment by segment ("pos" indicates the byte offset at which the read process starts with the length "length").

```
{
  "code": "request",
  "cid": -1,
  "adr": "/iolinkmaster/port[2]/datastorage/getblobdata",
  "data": {"pos": 0, "length": h}
}
{
  "code": "request",
  "cid": -1,
  "adr": "/iolinkmaster/port[2]/datastorage/getblobdata",
  "data": {"pos": h, "length": h}
}
{
  "code": "request",
  "cid": -1,
  "adr": "/iolinkmaster/port[2]/datastorage/getblobdata",
  "data": {"pos": 2*h, "length": h}
}
...
{
  "code": "request",
  "cid": -1,
  "adr": "/iolinkmaster/port[2]/datastorage/getblobdata",
  "data": {"pos": n*h, "length": h}
}
```

Example:

1st reading order: pos = 0, length = 256

2nd reading order: pos = 256, length = 256

3rd Read command: pos = 512, length = 256

Each segment is returned as a BASE64-encoded string.

► Connect segments (concatenate).

### Restore data memory

► Determine the size of the backed-up data storage content (n = number of bytes).

Example: n = 550

► Read segment size (s = number of bytes)

```
{
  "code": "request",
  "cid": -1,
  "adr": "/iolinkmaster/port[1]/datastorage/chunksize/getdata"
}
```

Example: s = 256

► Start writing the data storage string segment by segment ("size" = size of the read data storage)

```
{
  "code": "request",
  "cid": -1,
  "adr": "/iolinkmaster/port[1]/datastorage/start_stream_set",
  "data": {"size": n}
}
```

Example: size = 550

► Transmit data storage string segment by segment ("value" = string value with length s)

```
{
  "code": "request",
  "cid": -1,
  "adr": "/iolinkmaster/port[1]/datastorage/stream_set",
  "data": {"value": "aWZtfgIAAABBTDf4NXhfY25faXRfdDIuMi43Nw..."}
}
```

## Ports: Configuring the data transfer to LR AGENT / LR SMARTOBSERVER

Substructure: iolinkmaster/port[n] (n: 1...4)

Name	Description	Access
../senddatatosmob	Send process data to LR AGENT or LR SMARTOBSERVER	rw <sup>1</sup>

<sup>1</sup> read and write

## Ports: Reading / writing process data

Substructure: iolinkmaster/port[n] (n: 1...4)

Available data points:

Name	Description	Access
../pin2in	Digital input (pin 2)	ro <sup>1</sup>
../iolinkdevice/pdin	Input data (pin 4)	ro <sup>1</sup>
../iolinkdevice/pdout	Output data (pin 4)	rw <sup>2</sup>

<sup>1</sup> read only

<sup>2</sup> read and write; can only be changed if no connection to the fieldbus controller is active

### Example: Reading an IO-Link process value (operating mode "IO-Link")

**Task:** Read the current measured value of the ifm temperature sensor TN2531 at port 2.

**Solution:** Read the value of the pdin data point.

- Request:

```
{
  "code": "request",
  "cid": 4711,
  "adr": "/iolinkmaster/port[2]/iolinkdevice/pdin/getdata"
}
```

- Response:

```
{
  "cid": 4711,
  "data": {"value": "03C9"},
  "code": 200
}
```

The return value is displayed in hexadecimal format. The return value is given in hexadecimal format. Besides the temperature value the return value comprises additional information (→ IO Device Description (IODD) of the sensor). The temperature value is shown in bits 2 to 15.

0x03C9 = 0b1111001001

Temperature value: 0b11110010 = 242

This means that The current temperature value is 24.2 °C.

### Example: Writing an IO-Link process value

**Task:** The buzzer of the DV2500 at port 2 is to be switched on. The DV2500 operates in On/Off mode.

**Solution:** Write the value of the pdout data point. The IODD of the DV2500 shows the structure of the process value (e.g. LED activity). The buzzer is switched via bit 40 of the process value (OFF = 0, ON = 1).

Process sequence:

1. Read the current process value Example: Reading an IO-Link process value (operating mode "IO-Link") (→ [37](#)).
2. Set bit 40 of the read value to 1.
3. Write new process value.

Example:

Read process value:

0x0000 0000 004D = 0b0000 0000 0000 0000 0000 0000 0000 0000 0000 0000 0100 1101

New process value:

0b0000 0001 0000 0000 0000 0000 0000 0000 0000 0000 0100 1101 = 0x0100 0000 004D

- Request:

```
{
  "code": "request",
  "cid": 10,
  "adr": "iolinkmaster/port[2]/iolinkdevice/pdout/setdata",
  "data": {"newvalue": "01000000004D"}
}
```

- Response:

```
{
  "cid": 10,
  "code": 200
}
```

### Example: Reading the digital input value (operating mode "DI")

**Task:** The digital input value of the IO-Link device at port 2 (pin 4) is to be read. The operating mode of the IO-Link port is "Digital Input (DI)".

**Solution:** Write the process value of the pdin data point. The process value is returned as a hexadecimal value with a length of 1 byte (OFF = "00", ON = "01").

- Request:

```
{
  "code": "request",
  "cid": 10,
  "adr": "iolinkmaster/port[2]/iolinkdevice/pdin/getdata"
}
```

- Response:

```
{
  "cid": 10,
  "data": {"value": "00"},
  "code": 200
}
```

### Example: Writing the digital output value (operating mode "DO")

**Task:** The digital input value of the IO-Link device at port 2 (pin 4) is to be read. The operating mode of the IO-Link port is "Digital Input (DI)".

**Solution:** Write the process value of the pdin data point. The process value is returned as a hexadecimal value with a length of 1 byte (OFF = "00", ON = "01").

- Request:

```
{
  "code": "request",
  "cid": 10,
  "adr": "iolinkmaster/port[2]/iolinkdevice/pdin/getdata"
}
```

- Response:

```
{
  "cid":10,
  "data":{"value":"00"},
  "code":200
}
```

## Ports: Reading port events

A port event contains information about events on the IO-Link port (e.g. IO-Link device connected or disconnected, change of the operating mode of the port).

A port event is displayed as a value in hexadecimal format. The value is structured as follows:

Byte 2	Byte 1	Byte 0
Connection	reserved	Device

Legend:

- Connection      Connection status      1 byte
  - 0x00: No IO-Link device connected
  - 0x01: IO-Link device connected and in OPERATE state
- Device          IO-Link device status      1 byte
  - 0x01: Port activated, but no device connected
  - 0x02: Port activated and in "IO-Link" operating mode
  - 0x03: Port activated and in "DI" or "DO" operating mode

Substructure: iolinkmaster/port[n] (n: 1...4)

Available data points:

Name	Description	Access
../portevent	Port event	ro <sup>1</sup>

<sup>1</sup> read only

## 9.2.7 IO-Link devices

### IO-Link devices: Accessing parameters

The ifm IoT Core supports access to the parameters of connected IO-Link devices via the IT network using ISDU (Index Service Data Unit). Each parameter can be addressed via its ISDU index and ISDU subindex (→ IODD of the IO-Link device). If access to the IO-Link device is faulty, the ISDU error code will also be output in the response (→ IODD of the IO-Link device).

Substructure: iolinkmaster/port[n]/iolinkdevice (n: 1...4)

Applicable services:

Name	Description
../iolreadacyclic	Read a parameter of an IO-Link device (acyclic)
../iolwriteacyclic	Write a parameter of an IO-Link device (acyclic)

When using the validation level "Type compatible V1.1 Device with Backup + Restore":

After changing a parameter via ISDU write access, the user must end the parameter setting process with the "ParamDownloadStore" system command and activate the data storage mechanism on the IO-Link device.

- ▶ Set the SystemCommand object (ISDU index: 0x0002) to the value 0x05 (command "ParamDownloadStore") via acyclic ISDU write access.
- ▷ The parameter setting process is finished.
- ▷ The data storage mechanism on IO-Link device will be activated.

- ▷ The IO-Link device synchronises changed parameter values with data storage of the IO-Link master.

### Example: Reading a parameter value of an IO-Link device

**Task:** Reading the serial number of the ifm temperature sensor TN2531 at port 2.

**Solution:** Read the serial number with the `iolreadacyclic` service from the IO-Link device (index: 21, sub-index: 0)

- Request:

```
{
  "code": "request",
  "cid": 4711,
  "adr": "/iolinkmaster/port[2]/iolinkdevice/iolreadacyclic",
  "data": {"index": 21, "subindex": 0}
}
```

- Response:

```
{
  "cid": 4711,
  "data": {"value": "4730323134323830373130"},
  "code": 200
}
```

The returned value is displayed in hexadecimal format. Converting the HEX value to a STRING value results in: G0214280710.

### Example: Writing a parameter value of an IO-Link device

**Task:** Setting the output configuration OUT1 of the ifm temperature sensor TN2531 at port 2 to the value "Hnc / hysteresis function, normally closed".

**Solution:** Set the parameter [ou1] of the sensor with the service `iolwriteacyclic` to the value 4. The parameter can be accessed via IO-Link Index 580, Subindex 0 (→ IO-Link description of the sensor).

- Request:

```
{
  "code": "request",
  "cid": 4711,
  "adr": "/iolinkmaster/port[2]/iolinkdevice/iolwriteacyclic",
  "data": {"index": 580, "subindex": 0, "value": "34"}
}
```

The value must be passed in hexadecimal format. Converting the STRING value to a HEX value results in: 34.

- Response:

```
{
  "cid": 4711,
  "code": 200
}
```

### IO-Link devices: Reading and writing device information

Substructure: `iolinkmaster/port[n]/iolinkdevice` (n: 1...4)

Available data points:



Name	Description	Access
../status	Status of the connected IO-Link device	ro <sup>1</sup>
../vendorid	IO-Link ID of the manufacturer	ro <sup>1</sup>
../deviceid	IO-Link ID of the IO-Link device	ro <sup>1</sup>
../productname	Product name of the IO-Link device	ro <sup>1</sup>
../serial	Serial number of the IO-Link device	ro <sup>1</sup>
../applicationspecifictag	Device-specific identification (application tag)	rw <sup>2</sup>

<sup>1</sup> read only

<sup>2</sup> read and write

## IO-Link devices: Reading IO-Link events

The unit supports IO-Link events. IO-Link events are event and error messages. IO-Link events can be generated in the IO-Link master and in the connected IO-Link devices. IO-Link events generated in the IO-Link devices are forwarded to the IO-Link master and stored there.

An IO-Link event message has the following structure:

Byte 6	Byte 5	Byte 4	Byte 3	Byte 2	Byte 0...1
Instance	Mode	Type	Validity	Source	Event Code

### Legend

- Instance      IO-Link Event Qualifier: Trigger      1 byte
  - 0x00: unknown
  - 0x01: PL (Physical Layer)
  - 0x02: DL (Data Layer)
  - 0x03: AL (Application Layer)
  - 0x04: APPL (Application)
- Mode      IO-Link event Qualifier: Event trigger      1 byte
  - 0x40: one-time event or warning (single shot)
  - 0xC0: Error disappeared
  - 0x80: Error appeared
- Type      IO-Link Event Qualifier: Event category      1 byte
  - 0x10: Notification
  - 0x20: Warning
  - 0x30: Error
- Validity      Validity of the process data      1 byte
  - 0x00: valid
  - 0x40: not valid
- Source      IO-Link Event Qualifier: Event source      1 byte
  - 0x00: IO-Link device
  - 0xFF: IO-Link master
- Event Code      IO-Link event code (bytes are swapped!)      2 bytes      → IO-Link specification

Substructure: iolinkmaster/port[n]/iolinkdevice (n: 1...4)

Available data points:

Name	Description	Access
../iolinkevent	IO-Link event of the IO-Link device	ro <sup>1</sup>

<sup>1</sup> read only; Parameter only available if operating mode pin 4 (US) = IO-Link and IO-Link device is connected to port

## 9.2.8 Gateway

### Gateway: Resetting, rebooting and localising the device

Substructure: firmware

Applicable services:

Name	Description
../factoryreset	Reset the IO-Link master to factory settings
../reboot	Reboot the IO-Link master
../signal	Trigger the flashing of the status LEDs

### Gateway: Reading device information

Substructure: deviceinfo

Available data points:

Name	Description	Access
../productcode	Article number	ro <sup>1</sup>
../vendor	Manufacturer	ro <sup>1</sup>
../devicefamily	Device family	ro <sup>1</sup>
../hwrevision	Hardware revision	ro <sup>1</sup>
../serialnumber	Serial number	ro <sup>1</sup>
../swrevision	Firmware version	ro <sup>1</sup>
../bootloaderrevision	Bootloader version	ro <sup>1</sup>
../extensionrevision	Firmware and bootloader version	ro <sup>1</sup>
../fieldbustype	Fieldbus	ro <sup>1</sup>

<sup>1</sup> read only

### Gateway: Reading status and diagnostic information

Substructure: processdatamaster

Available data points:

Name	Description	Access
../temperature	Temperature of the IO-Link master (value in °C)	ro <sup>1</sup>
../voltage	Present voltage value of the supply voltage US (value in mV)	ro <sup>1</sup>
../current	Present current value of the sensor supply US (value in mA)	ro <sup>1</sup>
../supervisionstatus	Status of the device supply US	ro <sup>1</sup>

<sup>1</sup> read only

## 9.2.9 Notifications

The ifm IoT Core offers the possibility to send event or time controlled notifications.

Notifications can be transmitted using the following protocols:

- HTTP (Hypertext Transfer Protocol)
- MQTT (Message Queuing Telemetry Transport)
- TCP (Transmission Control Protocol)
- WS (Web Sockets)

Notifications can be transmitted in the following formats:

- JSON
- CSV

Notifications are set up with the subscribe service (→ Service: subscribe [□ 76](#)).

Active notifications can be changed with the subscribe service (→ Service: subscribe [□ 76](#)).

All active notifications can be displayed with the getsubscriberlist service (→ Service: getsubscriberlist [□ 71](#)).

Information about an active notification can be displayed with the `getsubscriptioninfo` service (→ Service: `getsubscriptioninfo` [ 72]).

Active notifications can be unsubscribed using the `unsubscribe` service (→ Service: `unsubscribe` [ 77]).

## Event-controlled notifications

All data points that have the attribute `datachanged` can serve as triggers for event-controlled notifications. If the value of the subscribed data point changes, a notification will be sent with the selected information.

Available data points:

Name
<code>firmware/type/datachanged</code>
<code>iolinkmater/port[n]/portevent/datachanged</code>
<code>iolinkmaster/port[n]/iolinkdevice/iolinkevent/datachanged</code>
<code>connections/mqttconnection/status/datachanged</code>
<code>connections/mqttconnection/status/preset/datachange</code>
<code>connections/mqttconnection/mqttsetup/qos/datachanged</code>
<code>connections/mqttconnection/mqtcmdchannel/status/preset/datachanged</code>
<code>connections/mqttconnection/mqtcmdchannel/status/datachanged</code>
<code>connections/mqttconnection/mqtcmdchannel/mqtcmdchannelsetup/brokerip/datachanged</code>
<code>connections/mqttconnection/mqtcmdchannel/mqtcmdchannelsetup/cmdtopic/datachanged</code>
<code>connections/mqttconnection/mqtcmdchannel/mqtcmdchannelsetup/defaultreplytopic/datachanged</code>
<code>connections/mqttconnection/mqtcmdchannel/mqtcmdchannelsetup/brokerport/datachanged</code>

Applicable services:

Name	Description
<code>../subscribe</code>	Subsrcribe to notifications
<code>../unsubscribe</code>	Unsubscribing from notifications
<code>../getsubscriptioninfo</code>	Display information about notifications

## Time-controlled notifications

The ifm IoT Core offers 2 counters that serve as triggers for time-controlled notifications. If the counter value reaches a multiple of the set interval time, a notification will be sent with the selected information.

Substructure: `timer[1...2]`

Available data points:

Name	Description	Access
<code>../counter/datachanged</code>	current counter value e.g. 235	ro <sup>1</sup>
<code>../intervall</code>	Interval time of the counter (in ms) • 50: 50 ms ... • 2147483647: 2147483647 ms	rw <sup>2</sup>

<sup>1</sup> read only

<sup>2</sup> read and write

Applicable services:

Name	Description
../subscribe	Subsrcribe to notifications
../unsubscribe	Unsubscribing from notifications
../getsubscriptioninfo	Display information about notifications

### Example: Subscribing to notifications

**Task:** Every 0.5 seconds, the current values of the following parameters are to be sent regularly to a network server with the IP address 192.168.0.4/temp.

- cyclic IO-Link input data of the IO-Link device at IO-Link Port 2
- Operating temperature of the IO-Link master.



The following options are additionally available:

via WebSockets (ws://): Example: Using WebSockets (→ Example: Using WebSockets [47](#))

via MQTT (mqtt://): Example: Configuring the MQTT command channel (→ Example: Configuring the MQTT command channel [50](#))

### Solution:

► Subscribe to the required data using the subscribe service.

- Request:

```
{
  "code": "request",
  "cid": 4711,
  "adr": "/timer[1]/counter/datachanged/subscribe",
  "data": {
    "callback": "http://192.168.0.4:80/temp",
    "datatosend": [
      "/iolinkmaster/port[2]/iolinkdevice/pdin",
      "/processdatamaster/temperature"
    ]
  }
}
```

► Set the timer to 500 ms.

- Request:

```
{
  "code": "request",
  "cid": 4712,
  "adr": "/timer[1]/interval/setdata",
  "data": {
    "newvalue": 500
  }
}
```

- Response:

```
{
  "cid": 4712,
  "code": 200
}
```

- Notification (Format: JSON)

```
{
  "code": "event",
  "cid": 4711,
  "adr": "",
  "data": {
    "eventno": "6317",
    "srcurl": "/timer[1]/counter/datachanged",
    "payload": {
      "/timer[1]/counter": {"code": 200, "data": 1},
      "/processdatamaster/temperature": {"code": 200, "data": 39},
      "/iolinkmaster/port[2]/iolinkdevice/pdin": {"code": 200, "data": "03B0"}
    }
  }
}
```

GB

### Example: Changing a notification

**Task:** The existing subscription is to be changed (→ Example: Subscribing to notifications □ 44). Instead of the temperature of the IO-Link master, the operating voltage applied is to be transmitted.

**Solution:** Overwrite the existing subscription. For this purpose, the parameter values for "cid" and "callback" in the request must be the same as those of the existing subscription.

- Request:

```
{
  "code": "request",
  "cid": 4711,
  "adr": "/timer[1]/counter/datachanged/subscribe",
  "data": {
    "callback": "http://192.168.0.4:80/temp",
    "datatosend": [
      "/iolinkmaster/port[2]/iolinkdevice/pdin",
      "/processdatamaster/voltage"
    ]
  }
}
```

### Example: Subscribing to a notification in CSV format

**Task:** Every 2 seconds, the current values of the following parameters are to be sent to a network server with the IP address 192.168.0.4

- cyclic IO-Link input data of the IO-Link device at port 2
- Operating temperature of the IO-Link master.

The data should be transmitted in CSV format (comma separator).

#### Solution:

- ▶ Use the subscribe service to subscribe to the required data and set the output format to "csv0".



Data in CSV format can only be sent via TCP connection.

- Request:

```
{
  "code": "request",
  "cid": 1,
  "adr": "/timer[1]/counter/datachanged/subscribe",
  "callback": "tcp://192.168.50.59:1883/topic",
  "codec": "csv0",
  "data": {
    "datatosend": [
      "/iolinkmaster/port[2]/iolinkdevice/pdin",
      "/processdatamaster/temperature"
    ]
  }
}
```

► Set the interval of the timer to 2 seconds:

- Request:

```
{
  "code": "request",
  "cid": 4712,
  "adr": "/timer[1]/interval/setdata",
  "data": {"newvalue": 2000}
}
```

The cyclically sent notification has the following structure:

```
/timer[1]/counter/datachanged,6317,200,1,200,39,200,03B0
```

### Example: Unsubscribing from a notification

**Task:** The existing subscription Example: Subscribing to notifications (→ □ 44) is to be deleted.

**Solution:** Use the unsubscribe service to delete the subscription. For this purpose, the value of the parameter "callback" in the request must be equal to the value of the existing subscription.

- Request:

```
{
  "code": "request",
  "cid": 4711,
  "adr": "/timer[1]/counter/datachanged/unsubscribe",
  "data": {
    "callback": "http://192.168.0.4:80/temp"
  }
}
```

### Example: checking a notification

**Task:** Display information about the existing subscription Example: Subscribing to notifications (→ □ 44).

**Solution:** Use the service getsubscriptioninfo and the parameter values cid, "adr" and "callback" of the existing subscription to retrieve the information.

- Request:

```
{
  "code": "request",
  "cid": 4711,
  "adr": "/timer[1]/counter/datachanged/getsubscriptioninfo",
  "data": {
    "callback": "http://192.168.0.4:80/temp"
  }
}
```

- Response:

```
{
  "code": "request",
  "cid": 4711,
  "data": {
    "callback": "http://192.168.0.4:80/temp",
    "datatosend": [
      "/iolinkmaster/port[2]/iolinkdevice/productname",
      "/iolinkmaster/port[2]/iolinkdevice/pdin",
      "/processdatamaster/temperature"
    ]
  }
}
```

### 9.2.10 WebSocket support

The ifm IoT Core supports communication via WebSocket protocol. With WebSockets, the user can establish a full-duplex communication channel via a TCP connection.

WebSockets can be used for the following services:

- subscribe
- unsubscribe



Maximum number of simultaneous WebSocket connections: 8  
Fail-safe WebSocket connections (wss://) are not supported.

To transmit notifications via a WebSocket connection:

Establish WebSocket a connection (e.g. "ws://192.168.0.55:80/websocket")

- Option 1: without parameter "callback"
  - ▶ Send a subscribe/unsubscribe request without "callback" parameter.
  - ▷ ifm IoT-Core sends notifications about existing WebSocket connections.
- Option 2: with parameter "callback"
  - ▶ send subscribe/unsubscribe requests with "callback" parameter ("ws:///myTopic").
  - ▷ ifm IoT-Core sends notifications about existing WebSocket connections to the `myTopic` topic.

#### Example: Using WebSockets

**Task:** The current values of the following parameters are to be sent regularly to the myTopic data sink via an existing WebSocket connection:

- Product name of the IO-Link device at IO-Link port 2
- cyclic IO-Link input data of the IO-Link device at IO-Link Port 2
- Operating temperature of the IO-Link master.

**Solution:** Subscribe to the required data using the subscribe service.

- Request:

```
{
  "code": "request",
  "cid": 4711,
  "adr": "/timer[1]/counter/datachanged/subscribe",
  "data": {
    "callback": "ws:///myTopic",
    "datatosend": [
      "/iolinkmaster/port[2]/iolinkdevice/productname",
      "/iolinkmaster/port[2]/iolinkdevice/pdin",
      "/processdatamaster/temperature"
    ]
  }
}
```

If the notifications are to be transmitted via the existing WebSocket connection, but without a special data sink, the callback parameter is not required.

- Request:

```
{
  "code": "request",
  "cid": 4711,
  "adr": "/timer[1]/counter/datachanged/subscribe",
  "data": {
    "datatosend": [
      "/iolinkmaster/port[2]/iolinkdevice/productname",
      "/iolinkmaster/port[2]/iolinkdevice/pdin",
      "/processdatamaster/temperature"
    ]
  }
}
```

### 9.2.11 MQTT support

The ifm IoT Core supports the MQTT protocol. MQTT allows a client to communicate with the ifm IoT Core via a broker to request and receive data. The ifm IoT Core can publish data via an MQTT connection.

To enable MQTT communication, the user must perform the following sub-steps:

- ▶ Activate MQTT command channel.
- ▶ Optional: Set Quality of Service (QoS).
- ▶ Set the IP address and port number of the MQTT broker.
- ▶ Set topic.
- ▶ Set standard response topic.
- ▷ The command channel is created with the selected properties.
- ▷ The user can publish on the topic with the ifm IoT Core.
- ▷ MQTT clients can subscribe to the topic.

#### Configuring the MQTT connection

The following status diagram shows the influence of the `start`, `stop` and `reset` services on the status of an MQTT connection:



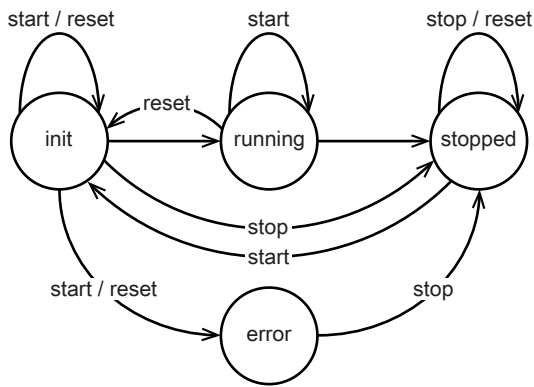

After the [init] state has been successful, the connection automatically changes to the [running] state. The connection automatically switches to the [error] state if at least one of the following events occurs:

- no MQTT broker available

**!** Maximum number of simultaneous MQTT connections: 10

Substructure: connections/mqttConnection

Name	Description	Access
../type	Type of the connection (MQTT)	ro <sup>1</sup>
../status	global status of the MQTT connection	ro <sup>1</sup>
../status/preset	Presetting of the status of the MQTT connection • running (default)	ro <sup>1</sup>
../MQTTSetup	Substructure for general MQTT settings	w
../MQTTSetup/QoS	Quality of Service (QoS) of the MQTT connection • 0: QoS Level 0 -PUBLISH (without confirmation) (default) • 1: QoS Level 1 -PUBLISH > PUBREC (one-time confirmation) • 2: QoS Level 2 - PUBLISH > PUBREC > PUBREL > PUBCOMP (double confirmation)	rw <sup>2</sup>
../MQTTSetup/version	MQTT version	ro <sup>1</sup>

<sup>1</sup> read only  
<sup>2</sup> read and write

Applicable services:

Name	Description
../status/start	Start MQTT connection
../status/stop	Stop MQTT connection
../status/reset	Reset MQTT connection

### Configuring the MQTT command channel

**!** Ensure that the MQTT broker can be reached and that the selected port of the MQTT broker is enabled for data transmission.

Wildcards "+" and "#" in topic names are not supported.

Substructure: connections/mqttConnection/mqttCmdChannel

Name	Description	Access
../type	Type of the command channel • mqtt: MQTT (default)	ro <sup>1</sup>
../status	Status of the command channel	ro <sup>1</sup>

Name	Description	Access
../status/preset	Presetting of the status of the command channel • running: Status [running] (default)	ro <sup>1</sup>
../mqttCmdChannelSetup	Substructure for the settings of the command channel	w
../mqttCmdChannelSetup/brokerIP	IP address of the MQTT broker	rw <sup>2</sup>
../mqttCmdChannelSetup/broker-Port	Port number of the MQTT broker	rw <sup>2</sup>
../mqttCmdChannelSetup/cmd-Topic	Designation of the MQTT topic	rw <sup>2</sup>
../mqttCmdChannelSetup/defaultReplyTopic	Standard response topic	rw <sup>2</sup>

<sup>1</sup> read only

<sup>2</sup> read and write

Applicable services:

Name	Description
../status/start	Start the MQTT command channel
../status/stop	Stop the MQTT command channel
../status/reset	Reset the MQTT command channel

### Example: Configuring the MQTT command channel

**Task:** Configuring and activating the MQTT command channel (IP address of the MQTT broker): 192.168.82.100, port: 1883, topic: abc, standard response topic: xyz, Quality of Service: Level 2)

#### Solution:

- ▶ Check whether MQTT broker can be reached and the port has been released.
- ▶ Activate command channel
- Request:

```
{
  "code": "request",
  "cid": 4711,
  "adr": "/connections/mqttConnection/mqttCmdChannel/status/start"
}
```

- ▶ Set the IP address of the MQTT broker.
- Request:

```
{
  "code": "request",
  "cid": 4712,
  "adr": "/connections/mqttConnection/mqttCmdChannel/mqttCmdChannelSetup/brokerIP/setdata",
  "data": {"192.168.82.100"}
}
```

- ▶ Set the port number of the MQTT broker.
- Request:

```
{
  "code": "request",
  "cid": 4713,
  "adr": "/connections/mqttConnection/mqttCmdChannel/mqttCmdChannelSetup/
brokerPort/setdata",
  "data": {"1883"}
}
```

► Set the topic.

- Request:

```
{
  "code": "request",
  "cid": 4714,
  "adr": "/connections/mqttConnection/mqttCmdChannel/mqttCmdChannelSetup/
cmdTopic/setdata",
  "data": {"abc"}
}
```

► Set standard response topic.

- Request:

```
{
  "code": "request",
  "cid": 4715,
  "adr": "/connections/mqttConnection/mqttCmdChannel/mqttCmdChannelSetup/
defaultReplyTopic/setdata",
  "data": {"xyz"}
}
```

► Set the Quality of Service.

- Request:

```
{
  "code": "request",
  "cid": 4716,
  "adr": "/connections/mqttConnection/MQTTSetup/QoS/setdata",
  "data": {"QoS2"}
}
```

### Example: Publishing the temperature to an MQTT broker

**Task:** Publish the temperature of the IO-Link master to an MQTT broker (IP address of the MQTT broker: 192.168.82.100, port: 1883, topic: abc).

**Solution:**

- Request:

```
{
  "code": "request",
  "cid": 1,
  "adr": "/timer[1]/counter/datachanged/subscribe",
  "data": {
    "callback": "mqtt://192.168.82.100:1883/abc",
    "datatosend": ["processdatamaster/temperature"]
  }
}
```

- Response:

```
{  
  "cid":-1,  
  "code":200  
}
```

## 9.2.12 ifm IoT Core Visualizer

The ifm IoT Core Visualizer provides a graphical user interface to access data and services of the ifm IoT Core.

### Starting the ifm IoT Core Visualizer

To start the ifm IoT Core Visualizer:

Requirements:

- ✓ The IO-Link master is connected to the IT network via the IoT port.
- ✓ Subnetwork
- ▶ Start web browser.
- ▶ Enter the address of the ifm IoT Core Visualizer: `http://ipadress/web/subscribe` (z. B. `http://192.168.178.1/web/subscribe`)
- ▷ The browser shows the ifm IoT Core Visualizer:

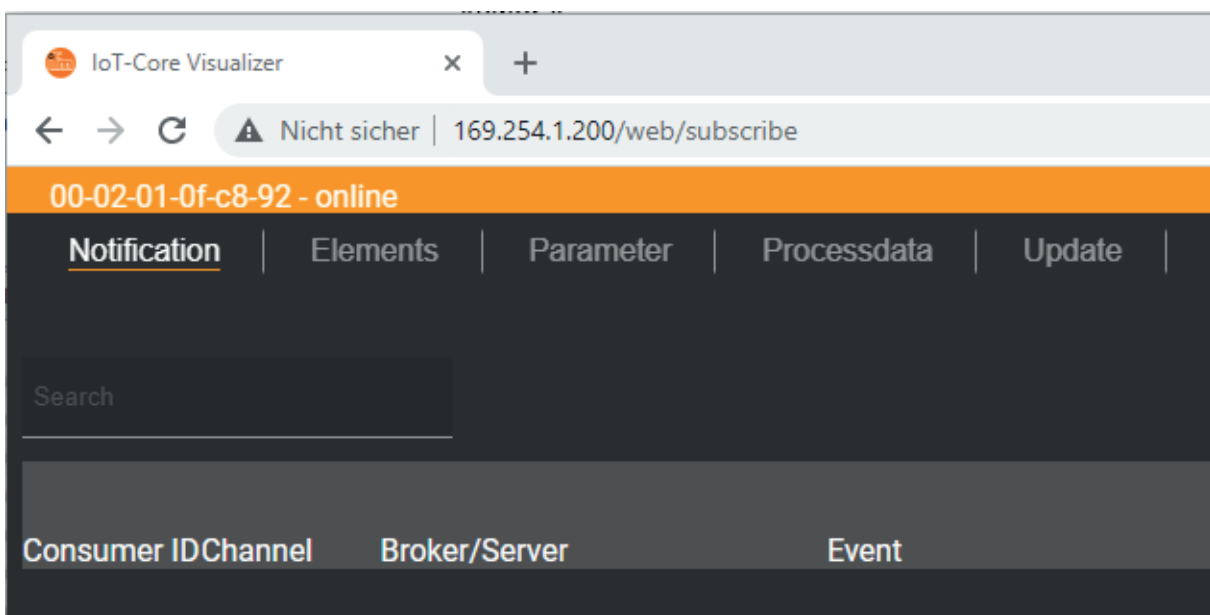

The navigation menu gives the user access to the following functions:

- [Notification]: Creating, managing and deleting notifications
- [Elements]: Searching for elements in the device description
- [Parameter]: Configuring the IO-Link master
- [Processdata]: Accessing process data
- Update: Updating the firmware

### Managing notifications

The menu page gives access to the following functions:

- Creating notifications
- Showing active notifications
- Deleting notifications (single, all)

Requirements:

- ✓ The ifm IoT Core Visualizer has been started.
- ▶ Click on [Notification].
- ▷ The menu page for managing notifications appears.

- ▷ The menu page shows all active notifications.

### Creating a new notification

A wizard is used to register new notifications.

Requirements:

- ✓ The [Notification] menu page is open
- ▶ Click on [+] on the right side of the table.
  - ▷ The wizard for the creation of notifications appears.

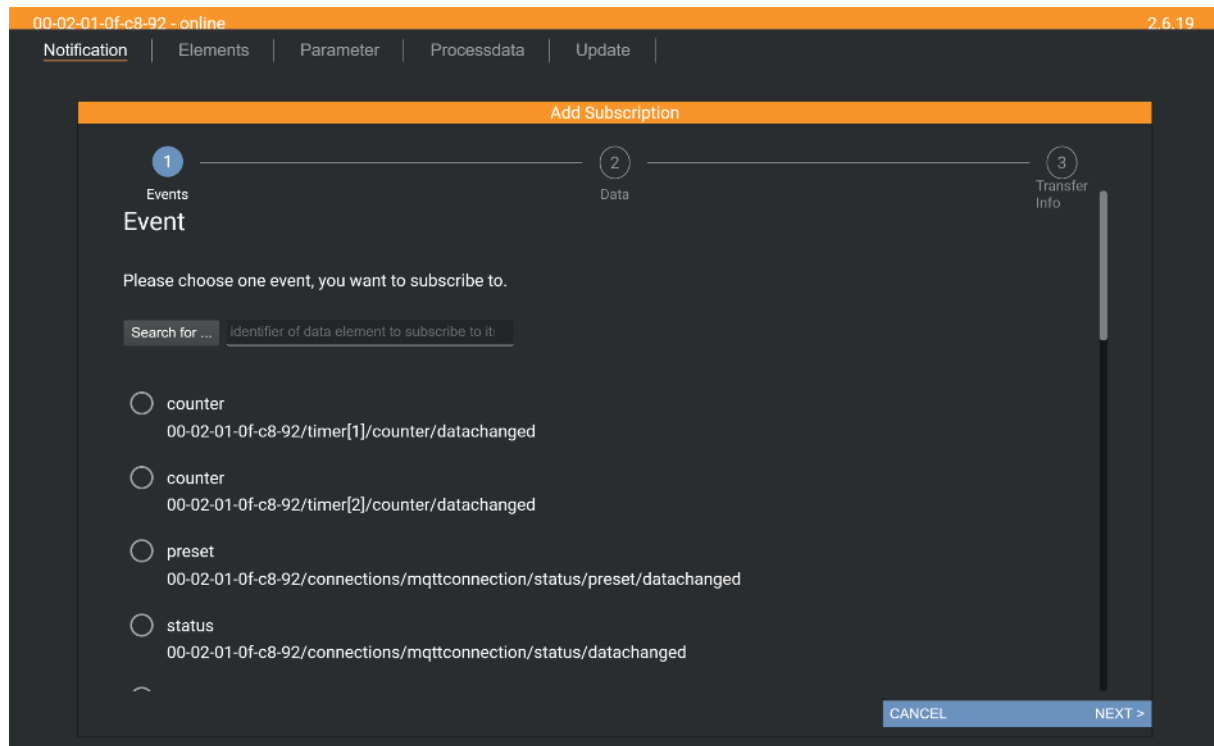

- ▶ Use the wizard to enter the required notification parameters step by step.
- ▷ The wizard generates a notification.
- ▷ The created notification is displayed in the table.



- ▶ For cyclical notifications via timer[1] or timer[2], set the interval time of the corresponding timer.

### Deleting a notification

To delete an active IODD:

Requirements:

- ✓ The [Notification] menu page is open
- ✓ At least one notification is active.
- ▶ Click on the [x] symbol in the [Unsubscribe] column.
- ▷ The selected notification will be deleted (unsubscribe).

### Searching for elements in the device description

The [Elements] menu page allows to search the device description for elements with specific properties ( type , profile , name ) and to output the results.

Requirements:

- ✓ The ifm IoT Core Visualizer has been started.

- ▶ Click on [Elements].
  - ▷ The menu page to search for elements appears.
  - ▷ The input mask appears.

The screenshot shows the web interface for the IO-Link master. At the top, there is a navigation bar with tabs: Notification, Elements (selected), Parameter, Processdata, and Update. The version number 2.6.19 is displayed in the top right corner. Below the navigation bar, there is a search input field labeled 'Search for ...'. Below the search field, there are three dropdown menus for 'identifier', 'profile', and 'type'. The 'identifier' dropdown is set to 'getdatamulti', the 'profile' dropdown is set to 'service', and the 'type' dropdown is empty. Below the search filters, there is a horizontal menu with options: Processdatamaster, Deviceinfo, Timer[1], Timer[2], lotsetup, Fieldbussetup, Connections, Iolinkmaster, and Firmware. Below this menu, there is a section for 'Devicetag' with a caret icon and the device ID '00-02-01-0f-c8-92'. Below the device ID, there is a table of search results:

Identifier	Path	Type	Profiles	Action
getidentity	00-02-01-0f-c8-92/getidentity	type: service	profiles: undefined	Copy URL
gettree	00-02-01-0f-c8-92/gettree	type: service	profiles: undefined	Copy URL
querytree	00-02-01-0f-c8-92/querytree	type: service	profiles: undefined	Copy URL
getsubscriberlist	00-02-01-0f-c8-92/getsubscriberlist	type: service	profiles: undefined	Copy URL

- ▶ Select the search criteria of the required element in the selection lists [identifier], [profile] and [type].
- ▶ Click on [Search for ...].
- ▷ The ifmIoT Core Visualizer searches the device description for elements with the selected search criteria.
- ▷ The result list shows all elements found.

## Configuring the IO-Link master

The [Parameter] menu page allows to configure the IO-Link master.

Available options:

- Reading and writing individual parameters
- Backup and restore the current configuration of the machine.

Requirements:

- ✓ The ifm IoT Core Visualizer has been started.
- ▶ Click on [Parameter].
- ▷ The menu page shows the available parameters of the IO-Link master.
- ▷ Current parameter values are displayed.
- ▶ Optional: Click on ↻ next to an element to manually update the process value.

The screenshot shows the configuration interface for an IO-Link master. At the top, there is a navigation bar with tabs: Notification, Elements, Parameter (selected), Processdata, and Update. Below this is a sub-menu with options: Deviceinfo, Timer[1], Timer[2], iotsetup (selected), Fieldbussetup, Connections, Iolinkmaster, Firmware, and Devicetag. The main content area is divided into two sections: 'iotsetup' and 'network'. The 'iotsetup' section shows a parameter 'accessrights' with a value of 'iot only'. To its right, there is a table of values for the 'accessrights' parameter:

Value	Description
0	fieldbus + iot
1	fieldbus + iot (read-only)
3	iot only

The 'network' section shows three parameters: 'macaddress' (00:02:01:0F:C8:92), 'ipaddress' (169.254.1.200), and 'subnetmask' (255.255.0.0). Each parameter has a 'Copy URL' button and a pencil icon for editing.

To change a parameter:

- ▶ Navigate to the desired parameter in the device description.
- ▶ Changing the parameter value
- ▶ Click on  to save the change on the IO-Link master.
- ▷ The changed parameter value is active.
- ▶ Optional: Repeat the procedure to change further parameter values.

### Accessing process data

The [Processdata] menu page makes it possible to read and write the process data of the IO-Link master and the connected IO-Link devices

Requirements:

- ✓ The ifm IoT Core Visualizer has been started.
- ▶ Click on [Processdata].
- ▷ Menu page shows the substructures of the device description that contain process data and events.
- ▷ The current process values are displayed.



GB

- ▶ Optional: Activate the [Polling] option and change the update interval.
- ▷ The process values will be updated with the set interval.
- ▶ Optional: Click on  next to an element to manually update the process value.

To change the value of a process date:

- ▶ Navigate to the required process date in the device description.
- ▶ Change the process value.
- ▶ Click on to save the change on the IO-Link master.
- ▷ Changes are saved on the IO-Link master.
- ▷ The changed process value is active.
- ▶ Optional: Repeat the procedure to change further process values.

## Updating the firmware

The [Update] menu page allows you to update the firmware of the IO-Link master:

Requirements:

- ✓ The ifm IoT Core Visualizer has been started.
- ▶ Click on [Update].
- ▷ Menu page displays information about the current firmware version.

- ▶ Click on [Load software file] and select a new firmware file (\*.bin).

- ▶ Click on [Update] to start the update process.
- ▷ The firmware of the IO-Link master will be updated.
- ▷ The area shows the progress of the update process.
- ▷ After successful update: The IO-Link master restarts automatically.

## 9.3 Powerlink

### 9.3.1 General information

The object directory of the device includes the following areas:

Index area	Description
0x1000 - 0x1FFF	Communication Profile Area
0x2000 – 0x2FFF	Manufacturer Specific Profile Area

Detailed description of the supported objects: Object directory (→ [□ 78](#))

A Powerlink cycle consists of an isochronous and an asynchronous phase.

In the isochronous phase, time-critical data is exchanged between the nodes in the network. A request-response mechanism is used for this (PReq: PollRequest; PRes: PollResponse) to transmit process data objects (PDO). The user must configure the content of TxPDO Configuring TxPDO (→ [□ 64](#)) and RxPDO Configuring RxPDO (→ [□ 65](#)).

The device supports the following PDOs:

- TxPDO: Powerlink Device > Powerlink Master
- RxPDO: Powerlink Master > Powerlink Device

In the asynchronous phase, non-time-critical data is exchanged between the nodes in the network (ASnd: Asynchronous Send). The following options are available for acyclic access to Service Data Objects (SDO):

- SDO access via ASnd
- SDO access via UDP

### 9.3.2 Installing the XDD file

To map the device in a Powerlink project planning software, ifm electronic provides an XDD file. The XDD (XML Device Description) describes the parameters, events and services of the device.



For instructions on how to install the XDD file: → User manual of the projection software

- ▶ Download the XDD file ([www.ifm.com](http://www.ifm.com)).
- ▶ Launch the Powerlink projection software.
- ▶ Install the XDD file of the device.
- ▷ The Powerlink projection software can access the data and functions of the device.

### 9.3.3 Gateway

#### Configuring access rights

The access rights define which control instance may read or write the parameters, process data and event / diagnostic messages.

Function	Object	Access
Set access rights	0x2F03: CurrentUseCase_U16 (→ <a href="#">□ 96</a> )	SDO

#### Configuring the Powerlink interface

The Powerlink interface of the device can be configured via the following objects:

Parameter / function	Object	Access
Setting the cycle time	0x1006: NMT_CycleLen_U32 (→ □ 79)	SDO
Host name	0x1F9A: NMT_HostName_VSTR (→ □ 87)	SDO
Setting the installation location	0x2E03: InstallationLocation_VSTR (→ □ 96)	SDO
Setting a new NodeID	0x2F04: NewNodeID_U8 (→ □ 97)	SDO



Note on setting the cycle time:

When setting a value outside the valid value range, the cycle time will be set automatically set to 0.

► Observe the valid value range!

## Reading device information

The following objects contain device and identification information:

Parameter / function	Object	Access
Device type	0x1000: NMT_DeviceType_U32 (→ □ 78)	SDO
Device Name	0x1008: NMT_ManufactDevName_VS (→ □ 79)	SDO
Hardware revision	0x1009: NMT_ManufactHwVers_VS (→ □ 79)	SDO
Software revision	0x100A: NMT_ManufactSwVers_VS (→ □ 80)	SDO
Identification information	0x1018: NMT_IdentityObject_REC (→ □ 80)	SDO
Article number	0x2E00: OrderNumber_VSTR (→ □ 95)	SDO
Date of production	0x2E01: ManufacturingDate_VSTR (→ □ 95)	SDO
QA date	0x2E02: QSDate_VSTR (→ □ 96)	SDO
Uptime	0x2F00: Timestamp_U64 (→ □ 96)	SDO

## Resetting the device

The user can reset the unit to its factory settings via the Powerlink network.

Function	Object	Access
Resetting the device	0x2F01: ResetToFactory_U16 (→ □ 96)	SDO

## Using the localisation function

To signal the location of the unit in an installation, the user can use the localisation service (flashing of the status LEDs of the unit).

Function	Object	Access
Activating the localisation function	0x2F02: DeviceLocalization_U8 (→ □ 96)	SDO

## 9.3.4 Ports

### Configuring the ports

A port configuration includes the following parameters:

- Operating mode
- Cycle time
- Validation / Data Storage
- VendorID
- Device ID

Each port is configured via a separate object.

Access to port configuration via the following objects:

Function	Object	Access
Port 1: Port configuration	0x2801: IOLConfigurationPort1 (→ □ 92)	SDO
Port 2: Port configuration	0x2811: IOLConfigurationPort2 (→ □ 93)	SDO
Port 3: Port configuration	0x2821: IOLConfigurationPort3 (→ □ 93)	SDO
Port 4: Port configuration	0x2831: IOLConfigurationPort4 (→ □ 93)	SDO

To change the process data of a port:

- ▶ Select the object of the required port.
- ▶ Setting the values of the subindices 0x01...0x05 as required.
- ▶ Set subindex 0x06 to value 0xFF.
  - ▷ The set port configuration will be written to the IO-Link master.
- ▶ Read index 0x06 to determine the status of the write process.
  - ▷ The changed port configuration is active.

### Setting fail-safe values for outputs

Fail-safe values can be defined for digital outputs and IO-Link output data at pin 4. If the connection to the fieldbus level is interrupted, the device will write the defined fail-safe values to the outputs. The fail-safe values can be set separately for each port.

Access is possible via the following objects:

Function	Object	Access
Port 1: Configuration of fail-safe values	0x2803: IOLFailSafePort1 (→ □ 95)	SDO
Port 2: Configuration of fail-safe values	0x2813: IOLFailSafePort2 (→ □ 95)	SDO
Port 3: Configuration of fail-safe values	0x2823: IOLFailSafePort3 (→ □ 95)	SDO
Port 4: Configuration of fail-safe values	0x2833: IOLFailSafePort4 (→ □ 95)	SDO

## 9.3.5 IO-Link devices

### Accessing parameters of the IO-Link devices

The unit supports access to the parameters of connected IO-Link devices via the Powerlink network using ISDU (Index Service Data Unit). Each parameter can be addressed via its ISDU index and ISDU subindex (IO Device Description (IODD) of the IO-Link device).

Access is possible via the following objects:

Function	Object	Access
Port 1: Accessing IO-Link devices	0x2800: IOLParamRWPort1 (→ □ 90)	SDO
Port 2: Accessing IO-Link devices	0x2810: IOLParamRWPort2 (→ □ 92)	SDO
Port 3: Accessing IO-Link devices	0x2820: IOLParamRWPort3 (→ □ 92)	SDO
Port 4: Accessing IO-Link devices	0x2830: IOLParamRWPort4 (→ □ 92)	SDO



Acyclic access via ISDU can take up to 5 s.

The IO-Link master can only process one access per port via ISDU. If another request is started during an active request, the IO-Link master will respond with an error message.

- ▶ Read the response object to query the current access status of the port.

Principle of the acyclic command processing:

1. Start command request: Write object / subindex 0x01
  - Command type (read / write)
  - Index / sub-index of the parameter
  - Length of the data to be transmitted (write command only)
  - Data (write command only)
2. Optional: Check the status of the command request: Read object / subindex 0x02
  - Status == 0xFF: Request is still being processed, repeat step 2
  - Status == 0x00 (write command): Request successfully processed, no return data available
  - Status == 0x01 (read command): Request successfully processed, return data available
  - Status == 0x02: Error, no return data available
  - Status == 0x03: Error, return data available
3. Optional: Read diagnostic codes: Read object / subindex 0x03
  - IO-Link Error Code (→ IODD of the IO-Link device)
  - Additional Code (→ IODD of the IO-Link Device)
4. Read return data: Read object / subindex 0x04
  - Status from index 0x02 (for assignment)
  - Current parameter value
  - IO-Link Error Code (→ IODD of the IO-Link device)
  - Additional Code (→ IODD of the IO-Link Device)

When using the validation level "Type compatible V1.1 Device with Backup + Restore":

After changing a parameter via ISDU write access, the user must end the parameter setting process with the "ParamDownloadStore" system command and activate the data storage mechanism on the IO-Link device.

- ▶ Set the SystemCommand object (ISDU index: 0x0002) to the value 0x05 (command "ParamDownloadStore") via acyclic ISDU write access.
- ▷ The parameter setting process is finished.
- ▷ The data storage mechanism on IO-Link device will be activated.
- ▷ The IO-Link device synchronises changed parameter values with data storage of the IO-Link master.

### Example: Acyclic reading of parameters

**Task:** The output configuration OUT 2 of the ifm temperature sensor TCC501 is to be read. The sensor is connected to port 2 of the device.

**Solution:** Read the output configuration (Index: 590, sub-index: 0) via SDO on object 0x2810

- ▶ Start command request: Write subindex 0x01 of object 0x2810 via SDO as follows:

<b>Byte 0</b>	0x0	Command "Read"
<b>Byte 1</b>	0x4E	Index (LSB)
<b>Byte 2</b>	0x02	Index (MSB)
<b>Byte 3</b>	0x00	Sub-index

- ▶ Check the status of the command request: Read subindex 0x02 of object 0x2810 via SDO
  - ▷ If subindex 0x02 == 0x01: Request successfully processed, return data available
  - ▷ If subindex 0x02 == 0x02: Error occurred, no return data available
  - ▷ If subindex 0x02 == 0x03: Error occurred, return data available

► Read return data: Read subindex 0x04 of object 0x2810 via SDO

Byte 0	0x01	Processing status (→ subindex 0x02)
Byte 1	0x00	reserved
Byte 2	0x00	IO-Link Error Code
Byte 3	0x00	IO-Link Additional Code
Byte 4	0x01	Length of the returned data (number of bytes)
Byte 5	0x0A	read parameter value

The read parameter value 0x0A (= 10) means: Output configuration [OUT 2] = [InEG / analogue signal 20...4 mA] (→ IODD of the TCC501).

### Example: Acyclic writing of parameters

**Task:** The output configuration [OUT 2] of the ifm temperature sensor TCC501 is to be deactivated. The sensor is connected to port 2 of the device.

**Solution:** Set the output configuration (Index: 590, subindex: 0) via SDO to object 0x2810 at the value 0x10 (= [OFF / Output Off]).

► Start command request: Write subindex 0x01 of object 0x2810 via SDO as follows:

Byte 0	0x01	Command "Write"
Byte 1	0x4E	Index (LSB)
Byte 2	0x02	Index (MSB)
Byte 3	0x00	Sub-index
Byte 4	0x01	Length of the data to be written (number of bytes)
Byte 5	0x10	New parameter value

► Check the status of the command request: Read subindex 0x02 of object 0x2810 via SDO

- ▷ If subindex 0x02 == 0x00: Change of parameter value was successful
- ▷ If subindex 0x02 == 0x02: An error has occurred Read the IO-Link error code and the additional code in subindex 0x04
- ▷ If subindex 0x02 == 0x03: An error has occurred Read error code in subindex 0x04

► Read return data: Read subindex 0x04 of object 0x2810 via SDO

Byte 0	0x00	Processing status (→ subindex 0x02)
Byte 1	0x00	reserved
Byte 2	0xXX	IO-Link error code (IO-Link specification)
Byte 3	0xYY	Additional code (IO-Link specification)

### Setting information parameters of the connected IO-Link devices

An object contains the following information about the IO-Link device connected to the port:

- Port status
- Min. supported cycle time
- IO-Link revision
- Vendor ID
- Device ID
- Serial number
- Product name
- Length of the process data (outputs)
- Length of the process data (inputs)

There is a separate object for each port.

Access is possible via the following objects:

Function	Object	Access
Port 1: IO-Link device information	0x2802: IOLInformationPort1 (→ 94)	SDO
Port 2: IO-Link device information	0x2812: IOLInformationPort2 (→ 94)	SDO
Port 3: IO-Link device information	0x2822: IOLInformationPort3 (→ 94)	SDO
Port 4: IO-Link device information	0x2832: IOLInformationPort4 (→ 94)	SDO

### 9.3.6 Process data

The process data of the ports are mapped cyclically to the following objects:

Data	Object	Access
Digital inputs – pin 2	0x2400: PD_Pin2 (→ 88)	SDO, PDO
Input data - pin 4 (operating mode: "IO-Link" and "DI")	0x2700: PD_InPort1 (→ 90) 0x2710: PD_InPort2 (→ 90) 0x2720: PD_InPort3 (→ 90) 0x2730: PD_InPort4 (→ 90)	SDO, PDO
Output data - pin 4 (operating mode: "IO-Link" and "DO")	0x2300: PD_OutPort1 (→ 87) 0x2310: PD_OutPort2 (→ 88) 0x2320: PD_OutPort3 (→ 88) 0x2330: PD_OutPort4 (→ 88)	SDO, PDO

In addition, the unit cyclically generates status and diagnostic information about the process data in the Port Qualifier Information (PQI).

The PQIs are mapped to the following objects:

Data	Object	Access
Port Qualifier Information (PQI)	0x2500: PD_PQIPort1 (→ 89) 0x2510: PD_PQIPort2 (→ 89) 0x2520: PD_PQIPort3 (→ 89) 0x2530: PD_PQIPort4 (→ 89)	SDO, PDO

The PQI is input data.

- ▶ Evaluate the PQI byte to obtain information on the validity of the process data and the connection status of the IO-Link devices.

### Configuring TxPDO

TxPDO are used for the cyclical transmission of process data from the Controlled Node (AL1370) to the Managing Node (Powerlink Master).

The device provides 1 TxPDO.

The following objects can be mapped into the TxPDO:

- Digital inputs – pin 2
- Input data - pin 4 (operating mode "IO-Link" and "DI")
- Port Qualifier Information (PQI)

The TxPDO can be configured via the following objects:

Contents	Object
TxPDO communication parameters	0x1800: PDO_TxCommParam_00h_REC (→ 82)
TxPDO mapping parameters	0x1A00: PDO_TxMappParam_00h_AU64 (→ 82)





ifm electronic recommends configuring the TxPDO via the Automation Studio configuration software instead of via the objects 0x1800 and 0x1A00.

The configuration of the TxPDO includes the following steps:

1. Object 0x1800: Set the communication parameters of the TxPDO

Set the receiver (set NodeID of the Managing Node)

2. Object 0x1A00: Map the content of the objects in TxPDO

The assignment of the process data to be transmitted to the TxPDO is done via index and subindex of the corresponding object. In addition, the number of bytes and the start position (offset) in the TxPDO must be specified.

A mapping entry in object 0x1A00 comprises 64 bits and has the following structure:

Byte 12...15	Byte 8...11	Byte 4...7	Byte 0...3
Length	Offset	Sub-index	Index

### Example: Configuring TxPDO

**Task:** The following process data is to be transmitted cyclically from the device to the Powerlink control:

- Digital input (pin 4) of port 1
- 8 bytes IO-Link input data (pin 4) of port 2
- Digital inputs (pin 2) of ports 3 and 4
- Port Qualifier Information (PQI) of the ports 1...4

**Solution:** Configure TxPDO.

Requirements:

- ✓ Ports 1...4 are configured according to the specifications.
- ✓ IO-Link devices / sensors are configured accordingly.
- ✓ IO-Link devices / sensors are connected with the port 1...4.
- ▶ Set object 0x1A00 / subindex 0x00 to 0x00.
  - ▷ The current TxPDO mapping will be deleted.
- ▶ Set the subindices of the object 0x1A00 as follows:

Sub-index	Value	Description
0x01	0x0001 0000 00 01 2700	Digital input - pin 4
0x02	0x0004 0001 00 01 2710	IO-Link input data - pin 4 (bytes 0...3) of port 2
0x03	0x0004 0005 00 02 2710	IO-Link input data - pin 4 (bytes 4...7) of port 2
0x04	0x0002 0009 00 01 2400	Digital inputs - pin 2 of ports 3 and 4
0x05	0x0001 000B 00 01 2500	Port Qualifier Information (PQI) – port 1
0x06	0x0001 000C 00 01 2510	Port Qualifier Information (PQI) – port 2
0x07	0x0001 000D 00 01 2520	Port Qualifier Information (PQI) – port 3
0x08	0x0001 000E 00 01 2530	Port Qualifier Information (PQI) – port 4

- ▶ Set object 0x1A00 / subindex 0x00 to 0x08.
  - ▷ New TxPDO mapping is activated.

### Configuring RxPDO

RxPDO are used to transmit process data from the Managing Node (Powerlink Master) to the Controlled Node (AL1370).

The devices already supports 1 RxPDO.

The data transmitted in the RxPDO can be mapped to the following objects:

- Output data - pin 4 (operating mode "IO-Link" and "DO").

The RxPDO is configured via the following objects:

Contents	Object
RxPDO communication parameters	0x1400: PDO_RxCommParam_00h_REC (→ □ 81)
RxPDO mapping parameters	0x1600: PDO_RxMappParam_00h_AU64 (→ □ 81)



ifm electronic recommends configuring the RxPDO via the Automation Studio configuration software instead of via the objects 0x1400 and 0x1600.

The configuration of the RxPDO includes the following steps:

1. Object 0x1400: Set the communication parameters of the RxPDO

Set the sender of the RxPDO (NodeID of the Managing Node)

2. Object 0x1600: Mapping the content of the RxPDO to objects

The assignment of the process data transmitted in the RxPDO is done via index and subindex of the corresponding object. In addition, the number of bytes and the start position (offset) in the RxPDO must be specified.

A mapping entry in object 0x1600 comprises 64 bits and has the following structure:

Byte 12...15	Byte 8...11	Byte 4...7	Byte 0...3
Length	Offset	Sub-index	Index

### Example: Configuring RxPDO

**Task:** The following process data is to be transmitted and output cyclically from the Powerlink control (Managing Node) to the device:

- Digital output (pin 4) of port 1
- 4 bytes IO-Link output data (pin 4) of port 2

The data is to be output to the corresponding devices. The Powerlink control has the NodeID "3".

**Solution:** Configure RxPDO.

Requirements:

- ✓ Ports 1...2 are configured according to the specifications.
- ✓ IO-Link devices / actuators are configured accordingly.
- ✓ IO-Link devices / actuators are connected to port 1...2.
- ✓ TxPDO of the Powerlink control (Managing Node) is configured according to the requirements.
- ▶ Set object 0x1400 / subindex 0x01 to value 0x03.
  - ▷ Powerlink control is sender of the RxPDO.
- ▶ Set object 0x1600 / subindex 0x00 to the value 0x00.
  - ▷ Current RxPDO mapping will be deleted.
- ▶ Set the subindices of the object 0x1600 as follows:

Sub-index	Contents	Description
0x01	0x0001 0000 00 01 2700	Digital output – pin 4 of the port 1
0x02	0x0004 0001 00 01 2710	IO-Link output data - pin 4 (bytes 0...3) of port 2

- ▶ Set object 0x1600 / subindex 0x00 to value 0x02.
  - ▷ The new RxPDO mapping is active.
  - ▷ Cyclically sent process data will be output on the IO-Link devices / actuators.

### 9.3.7 Events

The unit supports IO-Link events. IO-Link events are event and error messages. IO-Link events can be generated in the IO-Link master and in the connected IO-Link devices. IO-Link events generated in the IO-Link devices are forwarded to the IO-Link master and stored there.

The following event types exist:

- Error
- Warnings
- Notification

#### Reading IO-Link events

Access to the IO-Link events via the following object:

Function	Object	Access
Read events	0x1003: ERR_History_ADOM (→ 78)	SDO

Each event entry comprises 20 bytes of data containing detailed information on the type, origin and status of the event. In addition, the entry provides the IO-Link event code (→ IO-Link specification).

The structure stores a maximum of 254 events. The number of events in the structure is shown in subindex 0x00. The latest event is always stored in subindex 0x01.

To delete all event entries:

- ▶ Set object 0x1003 / subindex 0x00 to value 0x00.

## 10 Maintenance, repair and disposal

The operation of the unit is maintenance-free.

- ▶ Dispose of the device in an environmentally friendly way in accordance with the applicable national regulations when it is no longer used.

### 10.1 Cleaning the housing surface

Clean the surface of the device when necessary.

- ▶ Disconnect the device.
- ▶ Clean the device from dirt using a soft, chemically untreated and dry cloth.
- ▶ In case of severe soiling, use a damp cloth.
- ▶ Do not use any caustic cleaning agents for this!

# 11 Appendix

## 11.1 ifm IoT Core

### 11.1.1 Profiles

Profile	Description
blob	Binary Large Object
deviceinfo	Identification information of a device
devicetag	Device-specific identification
iolinkdevice_full	IO-Link device
iolinkmaster	IO-Link master
network	Network
parameter	Parameter
processdata	Process data
service	Service
software	Software
software/uploadable-software	upgradeable software
timer	Counter

### 11.1.2 Types

Type	Description
structure	Structural element (e.g. a folder in the file system)
service	Service that can be addressed from the network
event	An event that can be started by the firmware and sends messages.
data	Data point
device	Root element a device represents

### 11.1.3 Services

#### Service: factoryreset

Name: factoryreset

Description: The service sets the parameters of the device to the factory settings.

Request ("data" field): none

Return ("data" field): none

#### Service: getblobdata

Name: getblobdata

Description: The service reads a Binary Large Object (blob).

Request ("data" field):

Data field	Mandatory field	Data type	Description
pos	mandatory	NUMBER	Byte position
length	mandatory	NUMBER	Size of the object (number of bytes)

Return ("data" field):

Data field	Mandatory field	Data type	Description
data	mandatory	STRING	data to be decoded (BASE64 coded)
crc	optional	HEX STRING	CRC of the data after decoding
md5	optional	HEX STRING	MD5 checksum of the data after decoding

### Service: getdata

Name: `getdata`

Description: The service reads the value of a data point and outputs it.

Request ("data" field): none

Return data ("data" field):

Parameter	Mandatory field	Data type	Description
value	mandatory	STRING	Value of the data point

### Service: getdatamulti

Name: `getdatamulti`

Description: The service sequentially reads the values of several data points and provides them. The value and the diagnostic code are provided for each data point.

Request ("data" field):

Data field	Mandatory field	Data type	Description
datatose	mandatory	ARRAY OF STRINGS	List of data points to be requested; Data points must support the getdata service ("datatose":["url1", "url2", ..., "urlx"])

Return ("data" field):

Data field	Mandatory field	Data type	Description
url	mandatory	STRING	Data point request
code	mandatory	INT	Diagnostic code of the request
data	mandatory	STRING	Value of the data point

### Service: getelementinfo

Name: `getelementinfo`

Description: The service reads the properties of an element of the IoT tree.

Request ("data" field):

Parameter	Mandatory field	Data type	Description
adr	mandatory	STRING	URL of the element whose properties are to be changed

Return ("data" field):

Parameter	Mandatory field	Data type	Description
identifier	mandatory	STRING	Identifier of the element
type	mandatory	STRING	Type of the element
format	optional	JSON object	Format of the data or of the service content
uid	optional	STRING	
profiles	optional	JSON-ARRAY	Element profiles
hash	optional	STRING	

### Service: getidentity

Name: `getidentity`

Description: The service reads device information and outputs it.

Request ("data" field): none

Return ("data" field):

Parameter	Mandatory field	Data type	Description
iot.*		device	Device description as JSON object
iot.name	mandatory	STRING	Type of the element
iot.uid	optional	STRING	
iot.version	mandatory	STRING	
iot.catalogue	optional	ARRAY OF OBJECTS	
iot.deviceclass	optional	ARRAY OF STRING	
iot.serverlist	optional	ARRAY OF OBJECTS	
device	optional		VARIBALE_ARTNr
device.serialnumber	optional		Serial number
device.hwrevision	optional		Hardware version
device.swrevision	optional		software version
device.custom	optional		
security	optional		Security options
security.security-mode	optional	ENUM	shows if the security mode is activated
security.authscheme	optional	ENUM	shows the active authentication scheme
security.ispassword-set	optional	BOOL	shows whether the password has been set
security.activeconnection	optional	ENUM	connection type currently in use <ul style="list-style-type: none"> <li>• tcp_if: unencrypted http connection at the IoT interface, port 80</li> <li>• tls_if: encrypted https connection at the IoT interface, port 443</li> <li>• fb_if: unencrypted http connection at the fieldbus interface, port 80</li> </ul>

### Service: getsubscriberlist

Name: `getsubscriberlist`

Description: The service provides a list of all active subscriptions.

Request ("data" field): none

Return ("data" field): Array with the following data

Data field	Mandatory field	Data type	Description
adr	mandatory	STRING	Notification trigger
datatosend	mandatory	ARRAY OF STRINGS	List with URLs of the data elements; URLs are comma separated
cid	mandatory	STRING	ID of the active notification
callbackurl	mandatory	STRING	Destination address for the notifications
duration	mandatory	STRING	Activity duration

### Service: **getsubscriptioninfo**

Name: `getsubscriptioninfo`

Description: The service provides information about an active notification (subscribe). The following parameters of the active notification are to be used for the query:

- `cid` (e.g. 4711)
- `adr` (e.g. timer[1]/counter/datachanged)
- `callback` (e.g. http://192.168.82.121:8080/topic)

Request ("data" field):

Parameter	Mandatory field	Data type	Description
callback	mandatory	STRING	Destination address of the notifications; complete URL (e.g. http://ipaddress:port/path)

Return ("data" field):

Parameter	Mandatory field	Data type	Description
subscription	mandatory	BOOL	Status of the transferred parameters of the notification FALSE: Parameter incorrect TRUE: Parameter correct; Notification found
datatosend	mandatory	STRING	List with URLs of the data elements; URLs are comma separated
cid	mandatory	STRING	ID of the active notification
callbackurl	mandatory	STRING	Destination address of the notifications

### Service: **gettree**

Name: `gettree`

Description: The service reads the device description of the IO-Link master and outputs it as a JSON object. The output can be limited to a subtree of the device description.

Request ("data" field):

Parameter	Mandatory field	Data type	Description
adr	optional	STRING	Root element of the subtree
level	optional	STRING	max. level up to which the subtree is output <ul style="list-style-type: none"> <li>• no entry: all levels will be displayed</li> <li>• 0: do not display sub-elements ("subs")</li> <li>• 1: display sub-elements</li> <li>• 2: display sub-elements up to the 2nd level</li> <li>• 3: display sub-elements up to the 3rd level</li> <li>• ...</li> <li>• 20: display sub-elements up to the 20th level</li> </ul>

Return ("data" field)



Parameter	Mandatory field	Data type	Description
identifier	mandatory	STRING	Identifier of the root element
type	mandatory	STRING	Type of the element
format	optional	JSON object	Format of the data content
uid	optional	STRING	
profiles	optional	JSON array	
subs	mandatory	JSON array	Sub-elements
hash	optional	STRING	

### Service: install

Name: `install`

Description: The service installs the firmware stored in a memory area of the unit.

Request ("data" field): none

Return ("data" field): none

### Service: iolreadacyclic

Service: `iolreadacyclic`

Description: The service acyclically reads the parameter value of an IO-Link device. It is accessed via IO-Link index and subindex.

Request ("data" field):

Parameter	Mandatory field	Data type	Description
index	mandatory	NUMBER	IO-Link index of the parameter
subindex	mandatory	NUMBER	IO-Link subindex of the parameter

Return ("data" field):

Parameter	Mandatory field	Data type	Description
value	mandatory	STRING	Parameter value (value in hexadecimal format)

### Service: iolwriteacyclic

Name: `iolwriteacyclic`

Description: The service acyclically writes the parameter value of an IO-Link device. It is accessed via IO-Link index and subindex.

Request ("data" field):

Parameter	Mandatory field	Data type	Description
index	mandatory	NUMBER	IO-Link index of the parameter
subindex	mandatory	NUMBER	IO-Link subindex of the parameter
value	mandatory	STRING	Parameter value (value in hexadecimal format)

Return ("data" field): none

### Service: querytree

Name: `querytree`

Description: The service searches a device tree for the criteria `profile`, `type` and `name` and outputs a list with the URLs of the elements found. At least one of the search criteria must be specified. The service can only be executed on the root node of the machine.

Request ("data" field):

Parameter	Mandatory field	Data type	Description
profile	optional	STRING	Profile of the searched element
type	optional	STRING	Type of the searched element
name	optional	STRING	Type of the searched element

Return ("data" field):

Parameter	Mandatory field	Data type	Description
urlList	mandatory	ARRAY	Array with URLs of the found elements; URLs are separated by commas

### Service: reboot

Name: `reboot`

Description: The service reboots the device.

Request ("data" field): none

Return ("data" field): none

### Service: reset

Name: `reset`

Description: The service resets a connection to the initialisation state.

Request ("data" field): none

Return ("data" field): none

### Service: setblock

Name: `setblock`

Description: The service simultaneously sets the values of several data points of a structure.

Request ("data" field):

Parameter	Mandatory field	Data type	Description
datatset	mandatory	ARRAY OF OBJECTS	List of data points and their new values; Data points must support the <code>setdata</code> service
consitent	optional	BOOL	IO-Link subindex of the parameter

Return ("data" field): none

### Service: setdata

Name: `setdata`

Description: The service sets the value of the data point.

Request ("data" field):

Parameter	Mandatory field	Data type	Description
newvalue	mandatory	STRING	New value of the data point

Parameter	Mandatory field	Data type	Description
duration	optional	STRING	Duration of value storage <ul style="list-style-type: none"> <li>lifetime: Value is saved with IoT Core; Value remains valid even after restart of the device</li> <li>uptime: Value is saved until the next restart of the device</li> </ul>

Return ("data" field): none

### Service: signal

Name: `signal`

Description: The service triggers the flashing of the status LEDs of the unit.

Request ("data" field): none

Return ("data" field): none

### Service: start

Name: `start`

Description: The service starts a connection.

Request ("data" field): none

Return ("data" field): none

### Service: start\_stream\_set

Name: `start_stream_set`

Description: The service starts the sequential transmission of several data fragments.

Request ("data" field):

Parameter	Mandatory field	Data type	Description
size	mandatory	STRING	Overall length of the data to be transmitted (number of bytes)

Return ("data" field): none

### Service: stop

Name: `stop`

Description: The service stops a connection.

Request ("data" field): none

Return ("data" field): none

### Service: stream\_set

Name: `stream_set`

Description: The service transfers a data segment.

Request ("data" field):

Parameter	Mandatory field	Data type	Description
value	mandatory	BIN (BASE64)	Segment of the binary data (BASE64-coded)

Return ("data" field): none

**Service: subscribe**

Name: subscribe

Description:

Request ("data" field):

Parameter	Mandatory field	Data type	Description
callback	mandatory	STRING	Destination address for notifications; URL formats: <ul style="list-style-type: none"> <li>JSON: http://ipaddress:port/path</li> <li>JSON: ws:///path</li> <li>JSON: mqtt://ipadress:port/topic</li> <li>CSV: tcp://ipaddress:port/path</li> </ul>
datatosend	mandatory	ARRAY OF STRINGS	List with URLs of the data elements; URLs are comma-separated; Elements must support the getdata service
codec	optional	STRING	Format of the returned data <ul style="list-style-type: none"> <li>json: JSON formatted</li> <li>csv: CSV with standard separator (,)</li> <li>csv0: CSV formatted with comma separator (,)</li> <li>csv1: CSV formatted with semicolon separator (;)</li> </ul>
duration	optional	STRING	Duration of the notification activity <ul style="list-style-type: none"> <li>lifetime: Login remains permanently active, even after restarting the unit</li> <li>uptime: The login is active until the next reboot of the device</li> <li>once: send only one notification, user must unsubscribe immediately</li> </ul>

Return ("data" field): none

Notification format: JSON

```
{
  "code": "event",
  "cid": 4711,
  "adr": "",
  "data": {
    "eventno": "EventNo",
    "srcurl": "SrcURL",
    "payload": {
      "eventurl": {"code": "EventStatus", "data": "EventData"},
      "datapointurl_1": {"code": "DataStatus_1", "data": "DataValue_1"},
      "datapointurl_2": {"code": "DataStatus_2", "data": "DataValue_2"}, ...
    }
  }
}
```

Notification format: CSV

```
SrcURL,EventNo,EventStatus,EventData,DataStatus_1,DataValue_1,DataStatus_2,DataValue_2,...
```

- SrcURL: Source of the event (data point on which subscribe command was listed)
- EventNo: Event number
- EventStatus: Status code of the event
- EventData: Event data
- DataStatus\_1: Status code of the 1st element in list datatosend
- DataValue\_1: Value of the 1st element in list datatosend
- DataStatus\_2: Status code of the 2nd element in list datatosend

- `DataValue_2`: Value of the 2nd element in list `datatosend`

### Service: `unsubscribe`

Name: `unsubscribe`

Description: The service deletes an active notification. The values transferred for `cid` and `callback` must be the same as for the notification registration (`subscribe`). If the value "DELETE" is passed in the `callback`, all active subscriptions will be deleted.

Request ("data" field):

Parameter	Mandatory field	Data type	Description
<code>callback</code>	mandatory	STRING	Destination address for notifications; URL formats: <ul style="list-style-type: none"> <li>• JSON: <code>http://ipaddress:port/path</code></li> <li>• JSON: <code>ws:///path</code></li> <li>• JSON: <code>mqtt://ipaddress:port/topic</code></li> <li>• CSV: <code>tcp://ipaddress:port/path</code></li> <li>• DELETE: all active notifications are deleted</li> </ul>

Return ("data" field): none

### Service: `validation_useconnecteddevice`

Name: `validation_useconnecteddevice`

Description: The service checks whether the device ID and the vendor ID of the connected IO-Link device match the data points `../validation_vendorid` and `../validation_deviceid`.

Request ("data" field): none

Return ("data" field): none

## 11.2 Powerlink

### 11.2.1 Object directory

#### 0x1000: NMT\_DeviceType\_U32

Index	Sub-index	Name	Description	Data type / access
0x1000	-	DeviceType	Device type	UINT32 / const

#### 0x1001: ERR\_Error Register\_U8

Index	Sub-index	Name	Description	Data type / access
0x1001	-	ErrorRegister	Error register	UINT8 / ro

#### 0x1003: ERR\_History\_ADOM

Index	Sub-index	Name	Description	Data type / access
0x1003	-	History	History	ARRAY / -
	0x00	NumberOfEntries	Number of entries • 0x00: 0 (default) ... • 0xFE: 254	UINT8 / rw
	0x01...0xFE	ErrorEntry	Event record Mapping: Standard Entry (→ 78)	DOMAIN / ro

#### Mapping: Standard Entry

Byte	Bit 7	Bit 6	Bit 5	Bit 4	Bit 3	Bit 2	Bit 1	Bit 0
0	Entry Type (LSB)							
1	Entry Type (MSB)							
2	Error Type (LSB)							
3	Error Type (MSB)							
4...11	Time stamp							
12	Port No.							
13	Mode		Type		Source	Instance		
14	IOL Event Code							
15...19	reserved							

Legend:

- Entry Type      Entry type
- 2 bytes
- Bits 0...11: 0x001: Vendor-specific code
- Bits 12...13: 0x01: Error occurred and active
- Bit 14: 0x1: Emergency Queue
- Bit 15: 0x0: Type = error entry

• Error Type	Type of error	2 bytes	<ul style="list-style-type: none"> <li>• 0xFF01: IO-Link event</li> <li>• 0xFF02: Configuration error</li> <li>• 0xFF03: Status change: IO-Link device disconnected</li> <li>• 0xFF04: Status change: IO-Link device connected, but error occurred</li> <li>• 0xFF05: Status change: IO-Link device connected</li> <li>• 0xFF06: Mapping error for process data</li> </ul>
• Time stamp	Timestamp	8 bytes	
• Port No.	Port number	1 byte	<ul style="list-style-type: none"> <li>• 0x01: Port 1</li> <li>• 0x02: Port 2</li> <li>• ...</li> <li>• 0x08: Port 8</li> </ul>
• Mode	IO-Link Event Qualifier: Event mode	2 bits	<ul style="list-style-type: none"> <li>• 0x1: one-time notification or warning (single shot)</li> <li>• 0x2: Error disappeared</li> <li>• 0x3: Error appeared</li> </ul>
• Type	IO-Link Event Qualifier: Event category	2 bits	<ul style="list-style-type: none"> <li>• 0x1: Notification</li> <li>• 0x2: Warning</li> <li>• 0x3: Error</li> </ul>
• Source	IO-Link Event Qualifier: Event source	1 bit	<ul style="list-style-type: none"> <li>• 0x0: IO-Link device</li> <li>• 0x1: IO-Link master</li> </ul>
• Instance	IO-Link Event Qualifier: Event trigger	3 bits	<ul style="list-style-type: none"> <li>• 0x01: PHL (Physical Layer)</li> <li>• 0x02: DL (Data Layer)</li> <li>• 0x03: AL (Application Layer)</li> <li>• 0x04: APPL (Application)</li> </ul>
• IOL Event Code	IO-Link Event Code	1 byte	→ IO-Link specification

**0x1006: NMT\_CycleLen\_U32**

Index	Sub-index	Name	Description	Data type / access
0x1006	-	CycleLen	Cycle time (value in ms) <ul style="list-style-type: none"> <li>• 0x00000000: 0 ms</li> <li>• ...</li> <li>• 0x00001000: 4096 ms (default)</li> <li>• ...</li> <li>• 0xFFFFFFFF: 4294967295 ms</li> </ul>	UINT32 / rw

**0x1008: NMT\_ManufactDevName\_VS**

Index	Sub-index	Name	Description	Data type / access
0x1008	-	ManufactDevName	Device Name	STRING / ro

**0x1009: NMT\_ManufactHwVers\_VS**

Index	Sub-index	Name	Description	Data type / access
0x1009	-	ManufactHwVers	Hardware revision	STRING / ro

**0x100A: NMT\_ManufactSwVers\_VS**

Index	Sub-index	Name	Description	Data type / access
0x100A	-	ManufactSwVers	Software revision e.g. 0x000001	UINT32 / ro

**0x1018: NMT\_IdentityObject\_REC**

Index	Sub-index	Name	Description	Data type / access
0x1018	-	IdentityObject	Identification object	RECORD / -
	0x00	NumberOfEntries	Number of entries • 0x04: 4 (default)	UINT8 / const
	0x01	VendorId	Manufacturer ID • 0x0069666D: ifm electronic (default)	UINT32 / const
	0x02	ProductCode	Product Code: • 0x00AA1373: AL1373	UINT32 / const
	0x03	RevisionNo	Revision number • 0x00000001: 1 (default)	UINT32 / const
	0x04	SerialNo	Serial number	UINT32 / const

**0x1020: CFM\_VerifyConfiguration\_REC**

Index	Sub-index	Name	Description	Data type / access
0x1020	-	Verify configuration	Verification of the configuration	REC
	0x00	NumberOfEntries	Number of entries • 0x02: 2 (default)	UINT8 / ro
	0x01	ConfDate	Date of the last configuration • 0x00000000: 0 (default)	UINT32 / rw
	0x02	ConfTime	Time of the last configuration • 0x00000000: 0 (default)	UINT32 / rw

**0x1030: NMT\_InterfaceGroup\_0h\_REC**

Index	Sub-index	Name	Description	Data type / access
0x1030	-	InterfaceGroup	Interface parameters	RECORD / -
	0x00	NumberOfEntries	Number of entries • 0x09: 9 (default)	UINT8 / ro
	0x01	InterfaceIndex	Interface index • 0x0001: 1	UINT16 / const
	0x02	InterfaceDescription	Interface description • EPL Cn Interface: Ethernet Powerlink Controlled Node (default)	VSTRING / const
	0x03	InterfaceType	Interface type • 0x06: Ethernet CSMA/CD (default)	UINT8 / const
	0x04	InterfaceMtu	Interface packet size (value in bytes) • 1518: 1518 bytes	UINT16 / const
	0x05	Interface PhysAddress	Interface Address (physical)	OSTRING / const



Index	Sub-index	Name	Description	Data type / access
0x1030	0x06	InterfaceName	Interface name • eplcn0(default)	VSTRING / ro
	0x07	InterfaceOperStatus	Interface working status • 0x00: down • 0x01: on (default)	UINT8 / ro
	0x08	InterfaceAdminState	Interface administration status • 0x00: down • 0x01: on (default)	UINT8 / rw
	0x09	Valid_Bool	Validity • FALSE: not valid • TRUE: valid (default)	BOOL / rw

### 0x1300: SDO\_SequLayerTimeout\_U32

Index	Sub-index	Name	Description	Data type / access
0x1300	-	SeqLayerTimeout	Timeout for SDO communication • 0x00000064: 100 ms ... • 0x00015000: 86016 ms ... • 0xFFFFFFFF: 4294967295 ms	UINT32 / rw

### 0x1400: PDO\_RxCommParam\_00h\_REC

Index	Sub-index	Name	Description	Data type / access
0x1400	-	PDO_RxCommParam	Receive PDO Communication Parameter	RECORD / -
	0x00	NumberOfEntries	Number of entries • 0x02: 2 (default)	UINT8 / ro
	0x01	NodeID	Node ID of the transmitter of the RxPDO • 0x00: 0 (default) • 0x01: 1 ... • 0xEF: 239	UINT8 / rw
	0x02	MappingVersion	Mapping version • 0x00: 0 (default) • 0x01: 1 ... • 0xFF: 255	UINT8 / rw

### 0x1600: PDO\_RxMappParam\_00h\_AU64

Index	Sub-index	Name	Description	Data type / access
0x1600	-	PDO_RxMappParam	Receive PDO Mapping Parameter	ARRAY / -
	0x00	NumberOfEntries	Number of entries	UINT8 / rw
	0x01...0x50	MappingEntry	Entry Mapping: Mapping Entry RxPDO (→ 81)	UINT64 / rw

### Mapping: Mapping Entry RxPDO

Bits 47...63	Bits 32...46	Bits 24...31	Bits 16...23	Bits 0...15
LLLL	OOOO	res.	SS	IIII

Legend:

- LLLL Length of the user data (number of bytes) 2 bytes e.g. 0x0004: 4 bytes
- OOOO Byte from which the user data is stored in the RxPDO (offset) 2 bytes e.g. 0x0008: Byte 8 (offset)
- SS Subindex of the object to which the received user data is to be mapped 1 byte
  - 0x01: Sub-index 0x01
  - ...
  - 0x08: Sub-index 0x08
- IIIL Index of the object to which the received user data is to be mapped 2 bytes
  - 0x2300: PD\_OutPort1 (→ ▯ 87)
  - 0x2310: PD\_OutPort2 (→ ▯ 88)
  - 0x2320: PD\_OutPort3 (→ ▯ 88)
  - 0x2330: PD\_OutPort4 (→ ▯ 88)

**0x1800: PDO\_TxCommParam\_00h\_REC**

Index	Sub-index	Name	Description	Data type / access
0x1800	-	PDO_TxCommParam	Transmit PDO Communication Parameter	RECORD / -
	0x00	NumberOfEntries	Number of entries <ul style="list-style-type: none"> <li>• 0x02: 2 (default)</li> </ul>	UINT8 / ro
	0x01	NodeID	Node ID of the receiver of the TxPDO <ul style="list-style-type: none"> <li>• 0x00: 0 (default)</li> <li>• 0x01: 1</li> <li>...</li> <li>• 0xEF: 239</li> </ul>	UINT8 / rw
	0x02	MappingVersion	Mapping version <ul style="list-style-type: none"> <li>• 0x00: 0 (default)</li> <li>• 0x01: 1</li> <li>...</li> <li>• 0xFF: 255</li> </ul>	UINT8 / rw

**0x1A00: PDO\_TxMappParam\_00h\_AU64**

Index	Sub-index	Name	Description	Data type / access
0x1A00	-	PDO_TxMappParam	transmit PDO mapping parameter	ARRAY / -
	0x00	NumberOfEntries	Number of entries <ul style="list-style-type: none"> <li>• 0x00: 0 (default)</li> <li>• 0x01: 1</li> <li>...</li> <li>• 0x50: 80</li> </ul>	UINT8 / rw
	0x01...0x50	MappingEntry	Entry Mapping: Mapping Entry TxPDO (→ ▯ 82)	UINT64 / rw

**Mapping: Mapping Entry TxPDO**

Bits 47...63	Bits 32...46	Bits 24...31	Bits 16...23	Bits 0...15
LLLL	OOOO	res.	SS	IIIL

Legend:

- LLLL Length of the user data (number of bytes) 2 bytes e.g. 0x0004: 4 bytes
- OOOO Byte from which the user data is to be stored in the TxPDO (offset) 2 bytes e.g. 0x0008: Byte 8 (offset)
- SS Sub-index of the object containing the user data 1 byte
  - 0x01: Sub-index 0x01
  - ...
  - 0x08: Sub-index 0x08

- IIII Index of the object containing the user data 2 bytes
  - 0x2400: PD\_Pin2 (→ □ 88)
  - 0x2500: PD\_PQIPort1 (→ □ 89)
  - 0x2510: PD\_PQIPort2 (→ □ 89)
  - 0x2520: PD\_PQIPort3 (→ □ 89)
  - 0x2530: PD\_PQIPort4 (→ □ 89)
  - 0x2700: PD\_InPort1 (→ □ 90)
  - 0x2710: PD\_InPort2 (→ □ 90)
  - 0x2720: PD\_InPort3 (→ □ 90)
  - 0x2730: PD\_InPort4 (→ □ 90)



### 0x1C0A: DLL\_CNCollision\_REC

Index	Sub-index	Name	Description	Data type / access
0x1C0A	-	CNCollision	Counter for frame collisions in the network	REC
	0x00	NumberOfEntries	Number of entries • 0x3: 3 (default)	UINT8 / const
	0x01	CumulativeCnt_U32	Counter reading • 0x0000: 0 (default)	UINT32 / rw
	0x02	ThresholdCnt_U32	Number of exceeded thresholds • 0x0000: 0 (default)	UINT32 / ro
	0x03	Threshold_U32	Limit value • 0x000F: 15 (default)	UINT32 / rw

### 0x1C0B: DLL\_CNLossSoC\_REC

Index	Sub-index	Name	Description	Data type / access
0x1C0B	-	CNLossSoC	Counter for losses SoC events	REC
	0x00	NumberOfEntries	Number of entries • 0x3: 3 (default)	UINT8 / const
	0x01	CumulativeCnt_U32	Counter reading • 0x0000: 0 (default)	UINT32 / rw
	0x02	ThresholdCnt_U32	Number of exceeded thresholds • 0x0000: 0 (default)	UINT32 / ro
	0x03	Threshold_U32	Limit value • 0x000F: 15 (default)	UINT32 / rw

### 0x1C0C: DLL\_CNLossSoA\_REC

Index	Sub-index	Name	Description	Data type / access
0x1C0C	-	CNLossSoA	Counter for losses SoA events	REC
	0x00	NumberOfEntries	Number of entries • 0x3: 3 (default)	UINT8 / const
	0x01	CumulativeCnt_U32	Counter reading • 0x0000: 0 (default)	UINT32 / rw
	0x02	ThresholdCnt_U32	Number of exceeded thresholds • 0x0000: 0 (default)	UINT32 / ro
	0x03	Threshold_U32	Limit value • 0x000F: 15 (default)	UINT32 / rw

**0x1C0D: DLL\_CNLossPReq\_REC**

Index	Sub-index	Name	Description	Data type / access
0x1C0D	-	CNLossPReq	Counter for losses PReq events	REC
	0x00	NumberOfEntries	Number of entries • 0x3: 3 (default)	UINT8 / const
	0x01	CumulativeCnt_U32	Counter reading • 0x0000: 0 (default)	UINT32 / rw
	0x02	ThresholdCnt_U32	Number of exceeded thresholds • 0x0000: 0 (default)	UINT32 / ro
	0x03	Threshold_U32	Limit value • 0x000F: 15 (default)	UINT32 / rw

**0x1C0E: DLL\_CNSoCJitter\_REC**

Index	Sub-index	Name	Description	Data type / access
0x1C0E	-	CNSoCJitter	Counter for SoC offset	REC
	0x00	NumberOfEntries	Number of entries • 0x3: 3 (default)	UINT8 / const
	0x01	CumulativeCnt_U32	Counter reading • 0x0000: 0 (default)	UINT32 / rw
	0x02	ThresholdCnt_U32	Number of exceeded thresholds • 0x0000: 0 (default)	UINT32 / ro
	0x03	Threshold_U32	Limit value • 0x000F: 15 (default)	UINT32 / rw

**0x1C0F: DLL\_CNCRCErrror\_REC**

Index	Sub-index	Name	Description	Data type / access
0x1C0F	-	CNCRCErrror	Checksum error counter	REC
	0x00	NumberOfEntries	Number of entries • 0x3: 3 (default)	UINT8 / const
	0x01	CumulativeCnt_U32	Counter reading • 0x0000: 0 (default)	UINT32 / rw
	0x02	ThresholdCnt_U32	Number of exceeded thresholds • 0x0000: 0 (default)	UINT32 / ro
	0x03	Threshold_U32	Limit value • 0x000F: 15 (default)	UINT32 / rw

**0x1C13: CNSoCJitterRange**

Index	Sub-index	Name	Description	Data type / access
0x1C13	-	CNSoCJitterRange	SoC frame offset area • 0x00000000: 0 ... • 0x000007D0: 2000 (default) ... • 0xFFFFFFFF: 68719476735	UINT32 / rw

**0x1C14: CNLossOfSoCTolerance**

Index	Sub-index	Name	Description	Data type / access
0x1C14	-	CNLossOfSoCTolerance	SoC frame loss tolerance <ul style="list-style-type: none"> <li>• 0x00000000: 0</li> <li>...</li> <li>• 0x000186A0: 100000 (default)</li> <li>...</li> <li>• 0xFFFFFFFF: 68719476735</li> </ul>	UINT32 / rw

**0x1E40: NWL\_IpAddrTable\_0h\_REC**

Index	Sub-index	Name	Description	Data type / access
0x1E40	-	IpAddrTable	IP address table	REC
	0x00	NumberOfEntries	Number of entries <ul style="list-style-type: none"> <li>• 0x5: 5 (default)</li> </ul>	UINT8 / const
	0x01	IfIndex	Interface index <ul style="list-style-type: none"> <li>• 0x001: (default)</li> </ul>	UINT16 / ro
	0x02	Addr	IP address of the Powerlink interface: <ul style="list-style-type: none"> <li>• 192.168.100.1 (default)</li> </ul>	IPAD / ro
	0x03	NetMask	Subnet mask <ul style="list-style-type: none"> <li>• 255.255.255.0 (default)</li> </ul>	IPAD / ro
	0x04	ReasmMaxSize	max. size of the IP datagram <ul style="list-style-type: none"> <li>• 0x000: 0 (default)</li> </ul>	UINT16 / ro
	0x05	DefaultGateway	IP address of the network gateway <ul style="list-style-type: none"> <li>• 192.168.100.254 (default)</li> </ul>	IPAD / rw

**0x1E4A: NWL\_IpGroup\_REC**

Index	Sub-index	Name	Description	Data type / access
0x1E4A	-	IpGroup	Information about IP stack	REC
	0x00	NumberOfEntries	Number of entries <ul style="list-style-type: none"> <li>• 0x2: 2 (default)</li> </ul>	UINT8 / const
	0x01	Forwarding	Enable / disable forwarding <ul style="list-style-type: none"> <li>• False: Forwarding disabled (host) (default)</li> <li>• True: Forwarding enabled (router)</li> </ul>	BOOL / ro
	0x02	DefaultTTL	Time-to-live value for IP header <ul style="list-style-type: none"> <li>• 0x40: 64 (default)</li> </ul>	UINT16 / rw

**0x1F81: NMT\_NodeAssignment\_AU32**

Index	Sub-index	Name	Description	Data type / access
0x1F81	-	NodeAssignment	Node assignments to the Powerlink master (managing node)	ARRAY OF U32 / -
	0x00	NumberOfEntries	Number of entries <ul style="list-style-type: none"> <li>• 0x00: 0 (default)</li> <li>...</li> <li>• 0xFE: 254</li> </ul>	UINT8 / rw
	0x01...0xFE	ErrorEntry	node number <ul style="list-style-type: none"> <li>• 0x00: 0 (default)</li> </ul>	UINT32 / rw

**0x1F82: NMT\_FeatureFlags\_U32**

Index	Sub-index	Name	Description	Data type / access
0x1F82	-	FeatureFlags	NMT: Feature Flags • 0x000102E7(default)	UINT32 / const

**0x1F83: NMT\_EPLVersion\_U8**

Index	Sub-index	Name	Description	Data type / access
0x1F83	-	EPLVersion	NMT: Powerlink version • 0x20(default)	UINT8 / const

**0x1F8C: NMT\_CurrNMTState\_U8**

Index	Sub-index	Name	Description	Data type / access
0x1F8C	-	CurrNMTState	NMT: Current NMT state • 0x1C(default)	UINT8 / ro

**0x1F93: NMT\_EPLNodeID\_REC**

Index	Sub-index	Name	Description	Data type / access
0x1F9E	-	ResetCmd	NMT: Powerlink NodeID	REC
	0x00	NumberOfEntries	Number of entries • 0x02: 2 (default)	UINT8 / const
	0x01	NodeID	NodeID of the device • 0x1(default)	UINT8 / ro
	0x02	NodeIDByHW_BOOL	Setup mode of the NodeID • TRUE (default)	BOOL /ro

**0x1F98: NMT\_CycleTiming\_REC**

Index	Sub-index	Name	Description	Data type / access
0x1F98	-	CycleTiming	NMT: Cyle time	RECORD
	0x00	NumberOfEntries	Number of entries • 0x09: 9 entries (default)	UINT8 / const
	0x01	IsochrTxMaxPayload	User data size TxPDO (number of bytes) • 0x05D2: 1490 bytes (default)	UINT16 / const
	0x02	IsochrRxMaxPayload	User data size RxPDO: (number of bytes) • 0x05D2: 1490 bytes (default)	UINT16 / const
	0x03	PResMaxLatency	Max. Latency Pres (Polling Response) • 0x000007D0: 2000 ms (default)	UINT32 / const
	0x04	PReqActPayloadLimit	set user data size (PReq) • 0x0024: 36 bytes	UINT16 / rw
	0x05	PResActPayloadLimit	set user data size (PRes) • 0x0024: 36 bytes	UINT16 / rw
	0x06	ASndMaxLatency	max. latency for ASnd responses to SoA requests (value in ns) • 0x000007D0: 2000 ns (default)	UINT32 / const

Index	Sub-index	Name	Description	Data type / access
0x1F98	0x07	MultiplCycleCnt	Length of the multiplex cycle (value = multiple of the Powerlink cycle) • 0x00: 0ns	UINT8 / rw
	0x08	AsyncMTU	max. frame size (asynchronous transmission) • 0x012C: 300 bytes (default)	UINT16 / rw
	0x09	Prescaler	SoC message toggle rate (value = number of cycles to complete) • 0x0002: 2 (default)	UINT16 / rw

**0x1F99: NMT\_CNBasicEthernetTimeout\_U32**

Index	Sub-index	Name	Description	Data type / access
0x1F99	-	CNBasicEthernetTimeout	NMT: Controlled Node Timeout • 0x00000000: 0 ... • 0x004B4C40: 5000000 ns (default) ... • 0xFFFFFFFF: 4294967295	UINT32 / rw

**0x1F9A: NMT\_HostName\_VSTR**

Index	Sub-index	Name	Description	Data type / access
0x1F9A	-	HostName	NMT: Host name of the device	UINT8 / rw

**0x1F9B: NMT\_MultipleCycleAssign\_AU8**

Index	Sub-index	Name	Description	Data type / access
0x1F9B	-	MultipleCycleAssign	NMT: ???	ARRAY OF UINT
	0x00	NumberOfEntries	Number of entries • 0x00: 0 ... • 0xFE: 254 (default)	UINT8 / rw
	0x00...0xFE	CycleNo	Cycle number • 0x00: 0 (default) ... • 0xFF: 254	UINT8 / rw

**0x1F9E: NMT\_ResetCmd\_U8**

Index	Sub-index	Name	Description	Data type / access
0x1F9E	-	ResetCmd	NMT: Reset command	UINT8 / rw

**0x2300: PD\_OutPort1**

Index	Sub-index	Name	Description	Data type / access
0x2300	-	PD_OutPort1	Port 1: Process data – outputs (pin 4)	RECORD / -

Index	Sub-index	Name	Description	Data type / access
0x2300	0x00	NumberOfEntries	Number of entries • 0x08: 8 entries (default)	UINT8 / ro
	0x01	Port1Output1	Output data – bytes 0...3	UINT32 / rw
	0x02	Port1Output2	Output data – bytes 4...7	UINT32 / rw
	0x03	Port1Output3	Output data – bytes 8...11	UINT32 / rw
	0x04	Port1Output4	Output data – bytes 12...15	UINT32 / rw
	0x05	Port1Output5	Output data – bytes 16...19	UINT32 / rw
	0x06	Port1Output6	Output data – bytes 20...23	UINT32 / rw
	0x07	Port1Output7	Output data – bytes 24...27	UINT32 / rw
	0x08	Port1Output8	Output data – bytes 28...31	UINT32 / rw

**0x2310: PD\_OutPort2**

Index	Sub-index	Name	Description	Data type / access
0x2310	-	PD_OutPort2	Port 2: Process data – outputs (pin 4)	RECORD / -
	0x00...0x08	Structure and content: 0x2300: PD_OutPort1 (→ □ 87)		

**0x2320: PD\_OutPort3**

Index	Sub-index	Name	Description	Data type / access
0x2320	-	PD_OutPort3	Port 3: Process data – outputs (pin 4)	RECORD / -
	0x00...0x08	Structure and content: 0x2300: PD_OutPort1 (→ □ 87)		

**0x2330: PD\_OutPort4**

Index	Sub-index	Name	Description	Data type / access
0x2330	-	PD_OutPort4	Port 4: Process data – outputs (pin 4)	RECORD / -
	0x00...0x08	Structure and content: 0x2300: PD_OutPort1 (→ □ 87)		

**0x2400: PD\_Pin2**

Index	Sub-index	Name	Description	Data type / access
0x2400	-	PD_Pin2	Process data – digital inputs (pin 2) Mapping: PD_Pin2 (→ □ 88)	UINT16 / ro

**Mapping: PD\_Pin2**

Byte	Bit 7	Bit 6	Bit 5	Bit 4	Bit 3	Bit 2	Bit 1	Bit 0
n	res.	res.	res.	res.	Port 4: DI2	Port 3: DI2	Port 2: DI2	Port 1: DI2
n+1	reserved							

Legend:

- DI2 Digital input pin 2: Digital input signal level pin 2
- 0: LOW
- 1: HIGH



**0x2500: PD\_PQIPort1**

Index	Sub-index	Name	Description	Data type / access
0x2500	-	PD_PQIPort1	Port 1: Port Qualifier Information (PQI) Mapping: Port Qualifier Information (→ □ 89)	UINT8 / ro

**Mapping: Port Qualifier Information**

Byte	Bit 7	Bit 6	Bit 5	Bit 4	Bit 3	Bit 2	Bit 1	Bit 0
n	DE	DA	DI4	DI2	MOUT	MIN	PVO	PVI

Legend:

- PVI Port validity input: Validity of the input data 1 bit
  - 0: not valid
  - 1: valid
- PVO Port validity output: Validity of the output data 1 bit
  - 0: not valid
  - 1: valid
- MIN Input Mappign State: shows whether process data of the port is mapped in TxPDO 1 bit
  - 0: not mapped
  - 1: mapped
- MOUT Output Mapping State: shows whether process data of the port is mapped in RxPDO 1 bit
  - 0: not mapped
  - 1: mapped
- DI2 Digital input pin 2: Digital input signal level (pin 2) 1 bit
  - 0: LOW
  - 1: HIGH
- DI4 Digital input pin 4: Digital input signal level (pin 4) 1 bit
  - 0: LOW
  - 1: HIGH
- DA Device available: shows if the IO-Link device has been detected and if the IO-Link device is in the "PREOPRATE" or in the "OPERATE" state 1 bit
  - 0: other states
  - 1: device detected and in "OPERATE" state
- DE Device error: shows whether error or warning 1 bit
  - 0: no error
  - 1: error (validation error, short circuit, etc.)

**0x2510: PD\_PQIPort2**

Index	Sub-index	Name	Description	Data type / access
0x2510	-	PD_PQIPort2	Port 2: Port Qualifier Information (PQI) Mapping: Port Qualifier Information (→ □ 89)	UINT8 / ro

**0x2520: PD\_PQIPort3**

Index	Sub-index	Name	Description	Data type / access
0x2520	-	PD_PQIPort3	Port 3: Port Qualifier Information (PQI) Mapping: Port Qualifier Information (→ □ 89)	UINT8 / ro

**0x2530: PD\_PQIPort4**

Index	Sub-index	Name	Description	Data type / access
0x2530	-	PD_PQIPort4	Port 4: Port Qualifier Information (PQI) Mapping: Port Qualifier Information (→ □ 89)	UINT8 / ro

**0x2700: PD\_InPort1**

Index	Sub-index	Name	Description	Data type / access
0x2700	-	PD_InPort1	Port 1: Process data - inputs (pin 4)	RECORD / -
	0x00	NumberOfEntries	Number of entries • 0x08: 8	UINT8 / const
	0x01	Port1Input1	Input data – bytes 0...3	UINT32 / ro
	0x02	Port1Input2	Input data – bytes 4...7	UINT32 / ro
	0x03	Port1Input3	Input data – bytes 8...11	UINT32 / ro
	0x04	Port1Input4	Input data – bytes 12...15	UINT32 / ro
	0x05	Port1Input5	Input data – bytes 16...19	UINT32 / ro
	0x06	Port1Input6	Input data – bytes 20...23	UINT32 / ro
	0x07	Port1Input7	Input data – bytes 24...27	UINT32 / ro
	0x08	Port1Input8	Input data – bytes 28...31	UINT32 / ro

**0x2710: PD\_InPort2**

Index	Sub-index	Name	Description	Data type / access
0x2710	-	PD_InPort2	Port 2: Process data - inputs (pin 4)	RECORD / -
	0x00...0x08		Structure and content: 0x2700: PD_InPort1 (→ □ 90)	

**0x2720: PD\_InPort3**

Index	Sub-index	Name	Description	Data type / access
0x2720	-	PD_InPort3	Port 3: Process data - inputs (pin 4)	RECORD / -
	0x00...0x08		Structure and content: 0x2700: PD_InPort1 (→ □ 90)	

**0x2730: PD\_InPort4**

Index	Sub-index	Name	Description	Data type / access
0x2730	-	PD_InPort4	Port 4: Process data - inputs (pin 4)	RECORD / -
	0x00...0x08		Structure and content: 0x2700: PD_InPort1 (→ □ 90)	

**0x2800: IOLParamRWPort1**

Index	Sub-index	Name	Description	Data type / access
0x2800	-	IOLParamRWPort1	Port 1: Acyclic access to IO-Link device	RECORD
	0x00	NumberOfEntries	Number of entries • 0x04: 4 entries	UINT8 / const
	0x01	command	Command Mapping: Commands (→ □ 91)	OSTRING / wo
	0x02	Status	Processing status	UINT8 / ro
	0x03	ErrorCode	Error code	UINT16 / ro
	0x04	Response	Return values Mapping: Response (→ □ 91)	OSTRING / ro

Legend:



- Status                  Processing status                                  1 byte
  - 0x00: Command processed, no errors, no return data
  - 0x01: Command processed, no errors, return data available
  - 0x02: Command processed, error, no return data
  - 0x03: Command processed, error, return data available
  - 0xFF: Command is still being executed
  
- ErrorCode              Error code    2 bytes
  - 0x1234
    - 0x12: IO-Link Error Code
    - 0x34: Additional Code
  - 0x0000...0xFFFF

### Mapping: Commands

Byte	Contents
0	Command code
1	Index (LSB)
2	Index (MSB)
3	Sub-index
4	Length
5...m	Data

Legend:

- Command code                  command    1 byte
  - 0x00: Get
  - 0x01: Write
  
- Index                                  ISDU index of the parameter (IO-Link device)                  2 byte
  - 0x1234:
    - 0x34 = index (LSB)
    - 0x12 = index (MSB)
  - 0x0000
  - ...
  - 0xFFFF
  
- Sub-index                              ISDU sub-index of the parameter (IO-Link device)                  1 byte
  - 00
  - ...
  - 0xFF
  
- Length                                  Number of bytes in "Data" (only for "write" command)                  1 byte
  - 0x00: 0 bytes
  - ...
  - 0xE8: 232 bytes
  
- Data                                      Data sent to the IO-Link device (only for "write" command)                  n bytes
  - Pro byte:
    - 0x00...0xFF

### Mapping: Response

Byte	Contents
0	Status
1	reserved
2...3	ErrorCode
4	DataLength
5...m	Data

Legend:

- **Status**                      Status code (mirrored from sub-index 0x02)                      1 byte
  - 0x00: Command processed, no errors, no return data
  - 0x01: Command processed, no errors, return data available
  - 0x02: Command processed, error, no return data
  - 0x03: Command processed, error, return data available
  
- **ErrorCode**                      Error code                      2 bytes                      0x0000...0xFFFF
  - 0x1234
  - 0x12: IO-Link Error Code
  - 0x34: Additional Code
  
- **DataLength**                      Number of bytes in "Data" (only for "read" command)                      1 byte
  - 0x00: 0 bytes
  - ...
  - 0xE8: 232 bytes
  
- **Data**                      Return data (only for "read" command)                      n bytes                      per byte:
  - 0x00...0xFF

**0x2810: IOLParamRWPort2**

Index	Sub-index	Name	Description	Data type / access
0x2810	-	IOLParamRWPort2	Port 2: Acyclic access to IO-Link device	RECORD
	0x00...0x04	Structure and content: 0x2800: IOLParamRWPort1 (→ □ 90)		

**0x2820: IOLParamRWPort3**

Index	Sub-index	Name	Description	Data type / access
0x2820	-	IOLParamRWPort3	Port 3: Acyclic access to IO-Link device	RECORD
	0x00...0x04	Structure and content: 0x2800: IOLParamRWPort1 (→ □ 90)		

**0x2830: IOLParamRWPort4**

Index	Sub-index	Name	Description	Data type / access
0x2830	-	IOLParamRWPort4	Port 4: Acyclic access to IO-Link device	RECORD
	0x00...0x04	Structure and content: 0x2800: IOLParamRWPort1 (→ □ 90)		

**0x2801: IOLConfigurationPort1**

Index	Sub-index	Name	Description	Data type / access
0x2801	-	IOLConfigurationPort1	Port 1: Port configuration	RECORD / -
	0x00	NumberOfEntries	Number of entries <ul style="list-style-type: none"> <li>• 0x06: 6 entries</li> </ul>	UINT8 / const.
	0x01	ModeConfig	Operating mode of the port (pin 4) <ul style="list-style-type: none"> <li>• 0x00: Inactive - port disabled</li> <li>• 0x01: Digital input</li> <li>• 0x02: Digital output</li> <li>• 0x03: IO-Link, in operate mode</li> <li>• 0xFF: unknown</li> </ul>	UINT8 / rw

Index	Sub-index	Name	Description	Data type / access
0x2801	0x02	MasterCycleTime	Cycle time <ul style="list-style-type: none"> <li>• 0x00: fastest possible IO-Link cycle time</li> <li>• 0x14: 2.0 ms</li> <li>• 0x24: 3.6 ms</li> <li>• 0x28: 4.0 ms</li> <li>• 0x44: 8.0 ms</li> <li>• 0x50: 12.8 ms</li> <li>• 0x58: 16.0 ms</li> <li>• 0x80: 32.0 ms</li> <li>• 0x94: 64.0 ms</li> <li>• 0xBC: 128.0 ms</li> <li>• 0xBF: 132.8 ms</li> </ul>	UINT8 / rw
	0x03	ValBackupConfig	Validation and data storage <ul style="list-style-type: none"> <li>• 0x00: No device check (validation off, DS off)</li> <li>• 0x01: Type compatible V1.0 (validation on, DS off, device V1.0)</li> <li>• 0x02: Type compatible V1.1 (validation on, DS off)</li> <li>• 0x03: Type compatible V1.1 Backup and Restore (validation on, DS upload and download)</li> <li>• 0x04: Type compatible V1.1 Restore (validation on, DS download only)</li> <li>• 0xFF: unknown (for reading only)</li> </ul>	UINT8 / rw
	0x04	VendorID	Setpoint for validation of the VendorID <ul style="list-style-type: none"> <li>• e.g. 0x0136: ifm electronic</li> </ul>	UINT16 / rw
	0x05	DeviceID	Preset value for validation of the DeviceID <ul style="list-style-type: none"> <li>• e.g. 0x00037D: ifm AL2330</li> </ul>	UINT32 / rw
	0x06	Reconfigure	Reconfigure port <ul style="list-style-type: none"> <li>• 0xFF (write): send changed port configuration to IO-Link master</li> <li>• 0xFF (read): Port is being configured</li> <li>• 0x00 (read): Idling</li> </ul>	UINT8 / rw

### 0x2811: IOLConfigurationPort2

Index	Sub-index	Name	Description	Data type / access
0x2811	-	IOLConfigurationPort2	Port 2: Port configuration	RECORD
	0x00...0x06	Structure and content: 0x2801: IOLConfigurationPort1 (→ □ 92)		

### 0x2821: IOLConfigurationPort3

Index	Sub-index	Name	Description	Data type / access
0x2821	-	IOLConfigurationPort3	Port 3: Port configuration	RECORD
	0x00...0x06	Structure and content: 0x2801: IOLConfigurationPort1 (→ □ 92)		

### 0x2831: IOLConfigurationPort4

Index	Sub-index	Name	Description	Data type / access
0x2831	-	IOLConfigurationPort4	Port 4: Port configuration	RECORD
	0x00...0x06	Structure and content: 0x2801: IOLConfigurationPort1 (→ □ 92)		

**0x2802: IOLInformationPort1**

Index	Sub-index	Name	Description	Data type / access
0x2802	-	IOLInformationPort1	Port 1: IO-Link information	RECORD
	0x00	NumberOfEntries	Number of entries • 0x0B: 11 entries	UINT8 / const
	0x01	PortStatus	Status information of the port • 0x00: Inactive - port deactivated • 0x01: Digital input • 0x02: Digital output • 0x03: IO-Link, in "OPERATE2 mode • 0x04: IO-Link, no device connected • 0x05: General error • 0x06: Error: wrong vendor ID • 0x07: Error: wrong device ID • 0x08: Error: wrong IO-Link revision • 0x09: Error: Invalid cycle time • 0x0A: Error: Invalid process data length (inputs) • 0x0B: Error: Invalid process data length (outputs) • 0x0C: Error: Short circuit • 0x0D: Error: Low voltage	UINT8 / ro
	0x02	MinCycleTime	shortest cycle time of the IO-Link devices	UINT8 / ro
	0x03	IOLRevision	IO-Link revision of the IO-Link device	UINT8 / ro
	0x04	VendorID	VendorID of the IO-Link device	UINT16 / ro
	0x05	DeviceID	Device ID of the IO-Link device	UINT32 / ro
	0x06	SerialNum	Serial number of the IO-Link device	STRING / ro
	0x07	ProdName	Product name of the IO-Link device	STRING / ro
	0x0A	PDLengthOut	Current length of the process data (outputs)	UINT8 / ro
	0x0B	PDLengthIn	Current length of the process data (inputs)	UINT8 / ro

**0x2812: IOLInformationPort2**

Index	Sub-index	Name	Description	Data type / access
0x2812	-	IOLInformationPort2	Port 2: IO-Link information	RECORD
	0x00...0x0B		Structure and content: 0x2802: IOLInformationPort1 (→ 94)	

**0x2822: IOLInformationPort3**

Index	Sub-index	Name	Description	Data type / access
0x2822	-	IOLInformationPort3	Port 3: IO-Link information	RECORD
	0x00...0x0B		Structure and content: 0x2802: IOLInformationPort1 (→ 94)	

**0x2832: IOLInformationPort4**

Index	Sub-index	Name	Description	Data type / access
0x2832	-	IOLInformationPort4	Port 4: IO-Link information	RECORD
	0x00...0x0B		Structure and content: 0x2802: IOLInformationPort1 (→ 94)	

**0x2803: IOLFailsafePort1**

Index	Sub-index	Name	Description	Data type / access
0x2803	-	IOLFailsafePort1	Port 1: Configuration of fail-safe values	RECORD
	0x00	NumberOfEntries	Number of entries • 0x02: 2 entries	UINT8 / const
	0x01	Select	Select fail-safe mode and fail-safe values • 0x00: deactivated • 0x01: hold data • 0x02: set to 0 • 0x03: preset pattern	UNSIGNED8 / rw
	0x02	Pattern	Byte pattern as fail-safe value (only valid if sub-index 0x01 = 0x03); depending on the length of the output data; superfluous bits will not be transmitted; missing bits are filled with "0" • e.g. 0x0204	OSTRING / rw

**0x2813: IOLFailsafePort2**

Index	Sub-index	Name	Description	Data type / access
0x2813	-	IOLFailsafePort2	Port 2: Configuration of fail-safe values	RECORD
	0x00...0x02	Structure and content: 0x2803: IOLFailsafePort1 (→ □ 95)		

**0x2823: IOLFailsafePort3**

Index	Sub-index	Name	Description	Data type / access
0x2823	-	IOLFailsafePort3	Port 3: Configuration of fail-safe values	RECORD
	0x00...0x02	Structure and content: 0x2803: IOLFailsafePort1 (→ □ 95)		

**0x2833: IOLFailsafePort4**

Index	Sub-index	Name	Description	Data type / access
0x2833	-	IOLFailsafePort4	Port 4: Configuration of fail-safe values	RECORD
	0x00...0x02	Structure and content: 0x2803: IOLFailsafePort1 (→ □ 95)		

**0x2E00: OrderNumber\_VSTR**

Index	Sub-index	Name	Description	Data type / access
0x2E00	-	OrderNumber	article number of the device VARIABLE:	VSTRING / const

**0x2E01: ManufacturingDate\_VSTR**

Index	Sub-index	Name	Description	Data type / access
0x2E01	-	ManufacturingDate	Date of manufacture of the unit	VSTRING / const

**0x2E02: QSDate\_VSTR**

Index	Sub-index	Name	Description	Data type / access
0x2E02	-	QSDate	QA date	VSTRING / const.

**0x2E03: InstallationLocation\_VSTR**

Index	Sub-index	Name	Description	Data type / access
0x2E03	-	InstallationLocation	Installation location of the unit (max. 20 characters)	VSTRING / rw

**0x2F00: Timestamp\_U64**

Index	Sub-index	Name	Description	Data type / access
0x2F00	-	Time stamp	Operating time of the unit in ns (ms granularity)	UINT64 / ro

**0x2F01: ResetToFactory\_U16**

Index	Sub-index	Name	Description	Data type / access
0x2F01	-	ResetToFactory	Reset device to factory settings <ul style="list-style-type: none"> <li>• 0xA500: Resetting the device</li> <li>• 0xA501: Rebooting the device</li> <li>• otherw.: no action</li> </ul>	UINT16 / where

**0x2F02: DeviceLocalization\_U8**

Index	Sub-index	Name	Description	Data type / access
0x2F02	-	DeviceLocalization	Activate localisation function (flashing function status LEDs) <ul style="list-style-type: none"> <li>• 0x00: The status LEDs are flashing.</li> <li>• otherw.: no action</li> </ul>	UINT8 / where

**0x2F03: CurrentUseCase\_U16**

Index	Sub-index	Name	Description	Data type / access
0x2F03	-	CurrentUseCase	Access rights to device read: <ul style="list-style-type: none"> <li>• 0x00: Powerlink + IoT</li> <li>• 0x01: Powerlink + IoT (read only)</li> <li>• 0x03: IoT only</li> </ul> write: <ul style="list-style-type: none"> <li>• 0xA500: Powerlink + IoT</li> <li>• 0xA501: Powerlink + IoT (read only)</li> <li>• 0xA503: IoT only</li> </ul>	UINT16 / rw



**0x2F04: NewNodeID\_U8**

Index	Sub-index	Name	Description	Data type / access
0x2F04	-	NewNodeID	Change the Powerlink NodeID of the machine • 0x01: NodeID 1 ... • 0xEF: NodeID 239	UINT8 / rw