



Operating instructions
Electronic pressure sensor

PNI02x

UK

11433188 / 00 01 / 2022

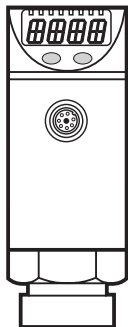

Contents

1 Preliminary note.....	3
1.1 Symbols used.....	3
2 Safety instructions	4
3 Function and features	4
4 Function.....	5
4.1 Processing of the measured signals.....	5
4.2 Analogue input.....	5
4.2.1 External sources/input modules for the analogue signal	6
4.2.2 Configuration of the analogue signal	7
5 Installation.....	8
6 Electrical connection.....	8
7 Controls and indicating elements.....	9
8 Menu.....	10
8.1 Menu structure.....	10
8.2 Explanation of the menu.....	11
9 Parameter setting	12
9.1 General parameter setting.....	12
9.2 Configuring the display (optional)	14
9.3 Setting the output signals	14
9.3.1 Setting of the output function.....	14
9.3.2 Setting of the switching limits	14
9.3.3 Setting of the input signal	15
9.4 User settings (optional).....	15
9.4.1 Setting of the Linear change of the switching thresholds (SP1/rP1; SP2/rP2).....	15
9.4.2 Calibration offset for P1	15
9.4.3 Setting of a time delay for the switching signals.....	16
9.4.4 Setting of the output logic for the switching outputs	16
9.4.5 Setting of the damping for the switching outputs.....	16
9.5 Service functions	16
9.5.1 Reading the min./max. values for P1, P2 or P1-2	16
9.6 Parameter setting for typical applications.....	17

9.6.1 Change the switch point by external potentiometer (1 kΩ potentiometer)	17
9.6.2 Differential pressure detection	18
9.6.3 Selection of an acceptable range by plc.....	19
9.6.4 Selection of the preset value with comparison of target/actual value .	20
9.6.5 Selection of the preset value with comparison of target/actual value .	21
9.6.6 Combination of two different physical quantitiesn	22
10 Operation.....	23
10.1 Reading of the set parameters	23
10.2 Fault indication	23
11 Technical data and scale drawing	23

1 Preliminary note

1.1 Symbols used

- ▶ Instruction
- > Reaction, result
- [...] Designation of keys, buttons or indications
- Cross-reference



Important note

Non-compliance may result in malfunction or interference.



Information

Supplementary note

2 Safety instructions

- The device described is a subcomponent for integration into a system.
 - The manufacturer is responsible for the safety of the system.
 - The system manufacturer undertakes to perform a risk assessment and to create a documentation in accordance with legal and normative requirements to be provided to the operator and user of the system. This documentation must contain all necessary information and safety instructions for the operator, the user and, if applicable, for any service personnel authorised by the manufacturer of the system.
- Read this document before setting up the product and keep it during the entire service life.
- The product must be suitable for the corresponding applications and environmental conditions without any restrictions.
- Only use the product for its intended purpose (→ Functions and features).
- Only use the product for permissible media (→ Technical data).
- If the operating instructions or the technical data are not adhered to, personal injury and/or damage to property may occur.
- The manufacturer assumes no liability or warranty for any consequences caused by tampering with the product or incorrect use by the operator.
- Installation, electrical connection, set-up, operation and maintenance of the product must be carried out by qualified personnel authorised by the machine operator.
- Protect units and cables against damage.
- Use in gases at pressures > 25 bar only after contacting the manufacturer ifm.

3 Function and features

The pressure sensor detects the system pressure of machines and installations.

Applications

Type of pressure: Relative pressure



Information on pressure rating and bursting pressure → data sheet.



Static and dynamic overpressures exceeding the indicated overload pressure are to be avoided by taking appropriate measures.

The indicated bursting pressure must not be exceeded. Even if the bursting pressure is exceeded only for a short time, the unit can be destroyed. NOTE: Risk of injury! Use in gases at pressures > 25 bar only after contacting the manufacturer ifm.

4 Function

4.1 Processing of the measured signals

- The unit shows the current system pressure on its display.
- It generates 2 output signals according to the set output configuration

4.2 Analogue input

In addition to the system pressure (P1) an analogue signal (P2) which can be configured can be supplied. It has influence on the switch points preset in the basic settings or on the preset window and on the pressure values displayed (display P2 or P1-P2).

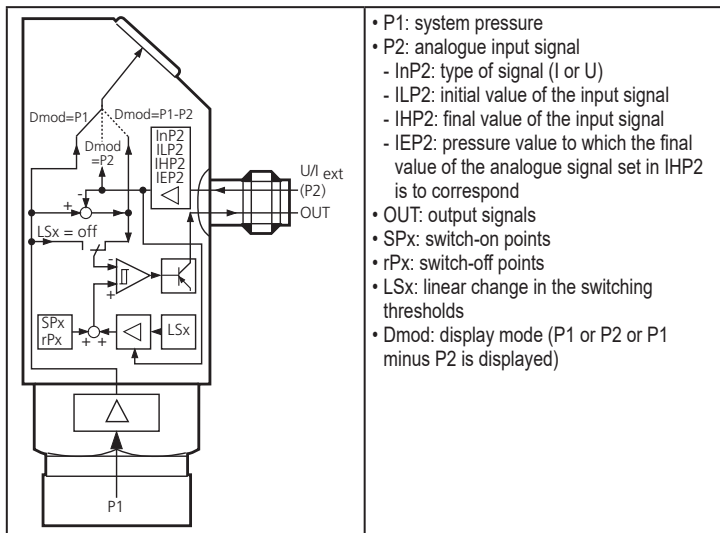

4.2.1 External sources/input modules for the analogue signal

A wide range of options is available:

- signal by passive encoder
- active current or voltage signal by external sensor or by plc
- selectable operating range (e.g. 4...20 mA, 0...10 V, 0...5 V).

Examples:

1. External potentiometer (11 k Ω) (e.g. 10-turn setting wheel)

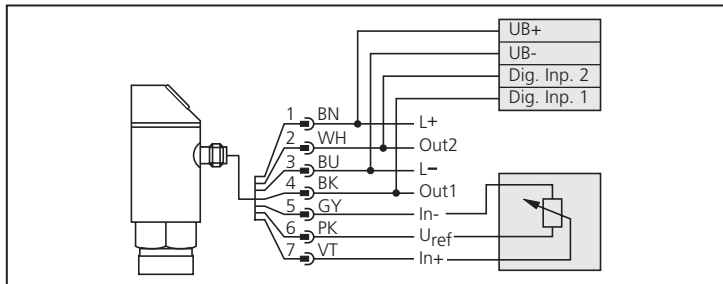

2. Additional sensor (e.g. pressure transmitter / temperature sensor)

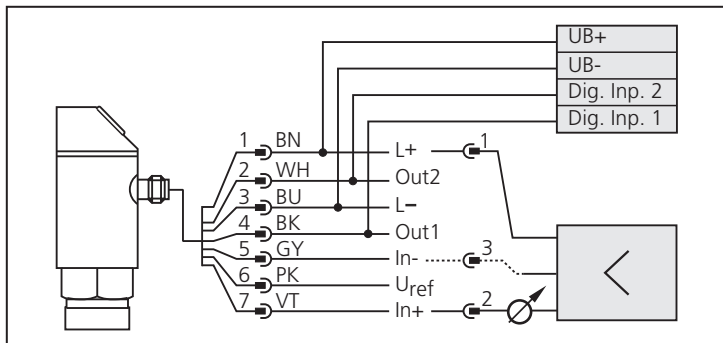

3. Intelligent controller (plc)

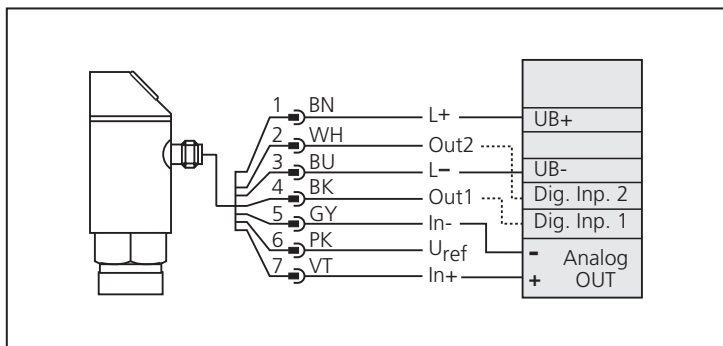

UK

4.2.2 Configuration of the analogue signal

4 parameters are available to adapt the external signal to the analogue input:

- INP2: type of signal (I or U).
- ILP2: initial value (LOW) of the analogue signal (e.g. 1 V).
- IHP2: final value (HIGH) of the analogue signal (e.g. 10 V).
- IEP2: pressure value to which the final value of the analogue signal set in IHP2 (e.g. 10 bar) is to correspond.

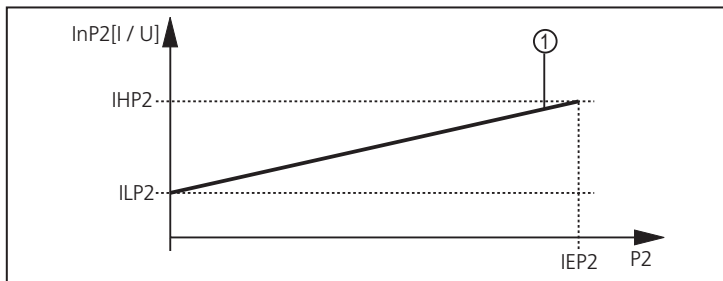

1: external analogue signal ($P2$)

5 Installation

! Before mounting and removing the sensor, make sure that no pressure is applied to the system.

- ▶ Insert the unit in a G $\frac{1}{4}$ process connection.
- ▶ Tighten firmly.

6 Electrical connection

! The unit must be connected by a qualified electrician.
The national and international regulations for the installation of electrical equipment must be adhered to.
Voltage supply to SELV, PELV.

- ▶ Disconnect power.
- ▶ Connect the unit as follows:

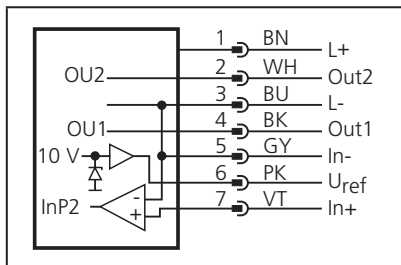

Core colours of ifm sockets:

1 = BN (brown), 2 = WH (white),
3 = BU (blue), 4 = BK (black)
5 = GY (grey), 6 = PK (pink)
7 = VT (lilac),
n.c. = not connected.

7 Controls and indicating elements

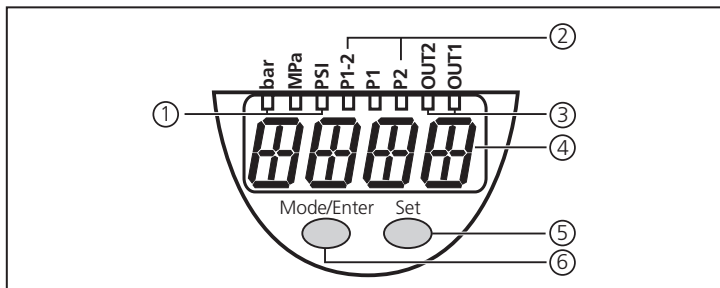

1: 3 x LED green

- Lighting LED = set display unit.

2: 3 x LED green

- Lighting LED = set display mode.

3: 2 x LED yellow

- Switching status; lights if the respective output has switched

4: 4-digit display

- Display of the system pressure,
- display of parameters and parameter values.

5: Set button

- Setting of the parameter values (scrolling by holding pressed; incremental by pressing briefly).

6: Mode / Enter button

- Selection of the parameters and acknowledgement of the parameter values.

8 Menu

8.1 Menu structure

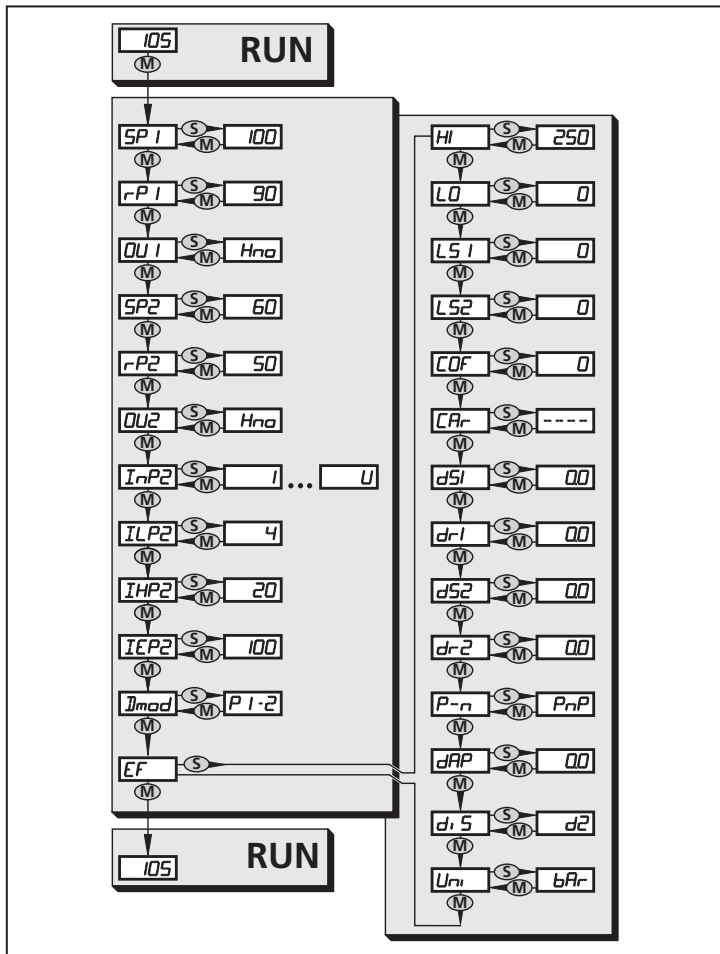

8.2 Explanation of the menu

SP1/rP1	Upper / lower limit value for system pressure at which OUT1 switches.
SP2/rP2	Upper / lower limit value for system pressure at which OUT2 switches.
OU1 / OU2	Output function for OUT1 / OUT2: <ul style="list-style-type: none"> Switching signal for the pressure limit values: hysteresis function [H ..] or window function [F ..], either normally open [. no] or normally closed [. nc].
InP2	Configuration of the analogue input.
ILP2	Initial value for the input signal.
IHP2	Final value for the input signal.
IEP2	Maximum value for the influence on the basic settings by the input signal (P2).
Dmod	Display mode.
EF	Extended functions / opening of menu level 2.
HI	Maximum value memory for P1, P2 or P1-2
LO	Minimum value memory for P1, P2 or P1-2
LS1/LS2	Linear change of the switching thresholds (SP1/rP1; SP2/rP2).
COF	Calibration offset for P1.
CAr	Calibration reset.
dS1/dS2	Switch-on delay for OUT1 / OUT2.
dr1/dr2	Switch-off delay for OUT1 / OUT2.
P-n	Output logic: pnp / npn.
dAP	Damping for the switching outputs.
diS	Update rate and orientation of the display.
Uni	Standard unit of measurement for system pressure.



UK

9 Parameter setting

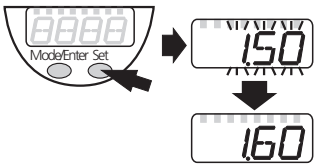

During parameter setting the unit remains in the operating mode. It continues its monitoring function with the existing parameters until the parameter setting has been completed.

9.1 General parameter setting

3 steps must be taken for each parameter setting:

1	Parameter selection ▶ Press [Mode/Enter] until the requested parameter is displayed.	
2	Setting of the parameter value ▶ Press [Set] and keep it pressed. > Current setting value of the parameter flashes for 5 s. > After 5 s: setting value is changed: incrementally by pressing the button once or continuously by keeping the button pressed.	
Numerical values are incremented continuously. To reduce the value: let the display move to the maximum setting value. Then the cycle starts again at the minimum setting value.		
3	Acknowledgement of the parameter value ▶ Press [Mode/Enter] briefly. > The parameter is displayed again. The new setting value is stored.	
Setting of other parameters: ▶ Start again with step 1.		
Finishing the parameter setting: ▶ Press [Mode/Enter] several times until the current measured value is displayed or wait for 15 s. > The unit returns to the operating mode.		

- Change from menu level 1 to menu level 2:

<ul style="list-style-type: none"> ▶ Press [Mode/Enter] until [EF] is displayed. 	
<ul style="list-style-type: none"> ▶ Press [Set] briefly. > The first parameter of the sub-menu is displayed (here: [Hi]). 	

- Locking / unlocking

UK

The unit can be locked electronically to prevent unintentional settings.

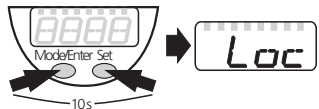
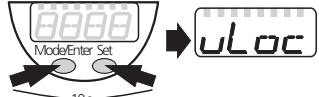
<ul style="list-style-type: none"> ▶ Make sure that the unit is in the normal operating mode. ▶ Press [Mode/Enter] + [Set] for 10 s. > [Loc] is displayed. 	
<p>During operation: [Loc] is briefly displayed if you try to change parameter values.</p>	
<p>For unlocking:</p> <ul style="list-style-type: none"> ▶ Press [Mode/Enter] + [Set] for 10 s. > [uLoc] is displayed. 	

On delivery: unlocked.

- Timeout:

If no button is pressed for 15 s during parameter setting, the unit returns to the operating mode with unchanged values.

9.2 Configuring the display (optional)

<p>▶ Select [Uni] and set the unit of measurement: - [bar], [MPa], [PSI].</p>	<i>Uni</i>
<p>▶ Select [diS] and set update rate and orientation of the display: - [d1]: Update of the measured value every 50 ms. - [d2]: Update of the measured value every 200 ms. - [d3]: Update of the measured value every 600 ms. - [rd1], [rd2], [rd3]: Display like d1, d2, d3; rotated by 180°. - [OFF]: The display is deactivated in the operating mode.</p>	<i>d1 S</i>
<p>▶ Select [Dmod] and set the display mode: - P1 = system pressure is displayed. - P2 = value at the analogue input is displayed (scaled with the value set in IEP2). - P1-2 = difference between P1 and P2. The unit set in Uni applies to all settings.</p>	<i>Dmod</i>

9.3 Setting the output signals

9.3.1 Setting of the output function

<p>▶ Select [OU1] and set the function: - [Hno] = hysteresis function / normally open - [Hnc] = hysteresis function / normally closed, - [Fno] = window function / normally open, - [Fnc] = window function / normally closed</p>	<i>OU 1</i>
<p>▶ Select [OU2] and set the function: - [Hno] = hysteresis function / normally open, - [Hnc] = hysteresis function / normally closed, - [Fno] = window function / normally open, - [Fnc] = window function / normally closed.</p>	<i>OU2</i>

9.3.2 Setting of the switching limits

<p>▶ Select [SP1] / [SP2] and set the value at which the output switches.</p>	<i>SP 1</i> <i>SP2</i>
<p>▶ Select [rP1] / [rP2] and set the value at which the output switches off. rPx is always smaller than SPx. The unit only accepts values which are lower than the value for SPx.</p>	<i>rP 1</i> <i>rP2</i>

ATTENTION: The entered values for SPx/rPx are initial values. The effect of the set switch points on the output stage is influenced by the analogue input P2 and the respective parameter settings (IxP2, LS1, LS2).

The display always shows the unchanged initial values.

9.3.3 Setting of the input signal

<p>▶ Select [InP2] and set the configuration of the input signal: - I = analogue current signal (max. range 0.00...20.00 mA). - U = analogue voltage signal (max. range 0.00...10.00 V). Factory preset = U.</p>	<p><i>InP2</i></p>
<p>▶ Select [ILP2] and set the initial value for the input signal: - 0.00...10.00 mA (for InP2 = I) - 0.00...5.00 V (for InP2 = U).</p>	<p><i>ILP2</i></p>
<p>▶ Select [IHP2] and set the final value for the input signal: - 10.00...20.00 mA (for InP2 = I) - 5.00...10.00 V (for InP2 = U). Minimum range ILP2 - IHP2 = 50% of the maximum value of IHP2.</p>	<p><i>IHP2</i></p>
<p>▶ Select [IEP2] and set the pressure value to which the final value of the analogue signal set in IHP2 is to correspond. Setting range: +/- final value of the measuring range of the basic unit.</p>	<p><i>IEP2</i></p>

UK

9.4 User settings (optional)

9.4.1 Setting of the Linear change of the switching thresholds (SP1/rP1; SP2/rP2)

<p>▶ Select [LS1] / [LS2] and set the value by which the preset switching threshold is to change when the analogue input value has reached its maximum. The preset standard value is „0“. The value can only be changed for special applications (→ 9.6.5). When LSx = OFF, the corresponding output switches independent of the analogue input value.</p>	<p><i>LS1</i> <i>LS2</i></p>
--	----------------------------------

9.4.2 Calibration offset for P1

<p>▶ Select [COF] and set a value between -5% and 5% of the final value of the measuring range. The internal measured value “0” is shifted by this amount.</p>	<p><i>COF</i></p>
<p>Calibration reset: ▶ Press [Mode/Enter] until [CAr] is displayed. ▶ Press [Set] until [----] is displayed. ▶ Press [Mode/Enter] briefly.</p>	<p><i>CAr</i></p>

9.4.3 Setting of a time delay for the switching signals

<p>[dS1] / [dS2] = switch-on delay for OUT1 / OUT2. [dr1] / [dr2] = switch-off delay for OUT1 / OUT2.</p> <p>▶ Select [dS1], [dS2], [dr1] or [dr2] and set a value between 0.1 and 50 s (at 0.0 the delay time is not active).</p>	<p>dS1 dS2 dr1 dr2</p>
--	------------------------------------

9.4.4 Setting of the output logic for the switching outputs

<p>▶ Select [P-n] and set [PnP] or [nPn].</p>	<p>P--n</p>
---	-------------

9.4.5 Setting of the damping for the switching outputs

<p>▶ Select [dAP] and set value between 0.01 and 4.00 s (at 0.00 = [dAP] is not active).</p> <p>dAP value = response time between pressure change and change of the switching status in seconds.</p> <p>[dAP] influences the switching frequency: $f_{\max} = 1 \div 2dAP$.</p> <p>[dAP] has effect on the system pressure (P1) and on the input signal (P2).</p>	<p>dAP</p>
--	------------

9.5 Service functions

9.5.1 Reading the min./max. values for P1, P2 or P1-2

<p>The unit set in [Dmod] is displayed / processed.</p> <p>▶ Select [HI] or [LO], press [Set] briefly. [HI] = maximum value, [LO] = minimum value.</p> <p>Delete memory:</p> <p>▶ Select [HI] or [LO].</p> <p>▶ Press [Set] until [----] is displayed.</p> <p>▶ Press [Mode/Enter] briefly.</p>	<p>HI LO</p>
---	------------------

9.6 Parameter setting for typical applications

9.6.1 Change the switch point by external potentiometer (1 k Ω potentiometer)

- If the system pressure exceeds the preset switch point, the pressure sensor is to provide a switched signal.
- Different operating steps require different preset switch points. They can be set by an external potentiometer with clear scale and markings for the different operating steps.

SP1 = 25 OU1 = Hno	Basic settings: Without influence by the potentiometer the output 1 switches when the value of 25 bar is exceeded.
InP2 = U	The potentiometer provides a control voltage.
ILP2 = 0.00	When the potentiometer is positioned at the left end stop, 0 V are supplied, no influencing of the switch point.
IHP2 = 10.00	When the potentiometer is positioned at the right end stop, 10 V are supplied, maximum influencing of the switch point.
IEP2 = 50	When the potentiometer is positioned at the right end stop SP1 is to be increased by max. 50 bar.

Display: Dmod = P1: system pressure is displayed.

Dmod = P2: shifting of the switch point in bar.

Wiring diagram: \rightarrow 4.2.1 example 1.

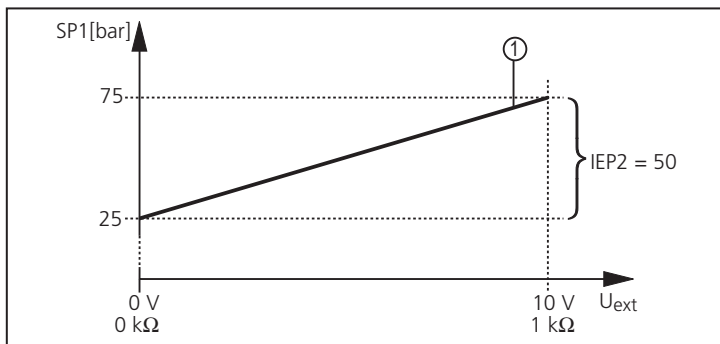

1: above the line output 1 is switched

9.6.2 Differential pressure detection

Filter monitoring (monitor degree of soiling)

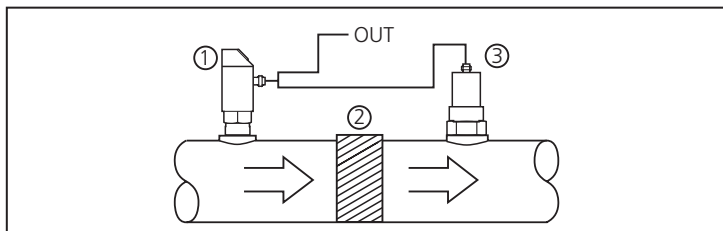

- The pressure sensor (1) detects the system pressure P_1 in front of the filter (2).
- An external sensor (3) with analogue output (4 ... 20 mA) detects the pressure behind the filter P_2 .
- The differential pressure $P_1 - P_2$ indicates the degree of soiling. As soon as it has exceeded 0.3 bar, the pressure sensor (1) provides a signal (output1 = ON) that filter maintenance is necessary..

Wiring diagram: → 4.2.1 example 2.

SP1 = 0.3 OU1 = Hno	Output 1 is to switch (= ON) when the differential pressure exceeds the value of 0.3 bar.
InP2 = I	The external sensor provides a current signal.
ILP2 = 4.00	For 0 bar the external sensor provides 4 mA.
IHP2 = 20.00	For 5 bar the external sensor provides 20 mA.
IEP2 = 5	Final value of the measuring range of the external sensor.

Display: Dmod = P1-2: differential pressure $P_1 - P_2$ is displayed.

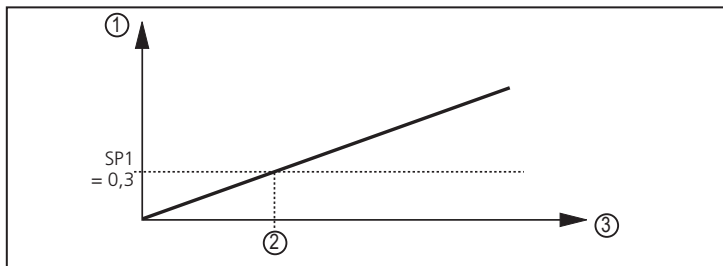

1: differential pressure $P_1 - P_2$ caused by the filter in bar; 2: permissible degree of soiling
3: degree of soiling of the filter

9.6.3 Selection of an acceptable range by plc

- The pressure sensor is to monitor the pressure within a defined window and give a warning when the pressure is outside this window (output 1 = OFF as long as the pressure is within the acceptable range, output 1 switches ON when the pressure leaves the acceptable range).
- Different operating steps require different windows. They are set by an analogue signal of the plc (0 ... 5V).

Wiring diagram: → 4.2.1 example 3.

SP1 = 20 rP1 = 18	Basic settings: Without influence by the plc the acceptable range is between 18 and 20 bar.
OU1 = Fnc	Window function/normally closed: OUT1 = OFF when pressure is within the acceptable range; OUT1 = ON (warning) when pressure leaves the acceptable range.
InP2 = U	The plc controls the window by a voltage signal.
ILP2 = 0	Minimum value of the control voltage = 0 V; no influence on basic settings.
IHP2 = 5	Maximum value of the control voltage = 5 V; maximum shift of the acceptable range.
IEP2 = 1	For maximum control voltage the acceptable range is to be shifted upwards by 1 bar.

UK

Display: Dmod = P1: system pressure is displayed.

Dmod = P2: the shift value is displayed.

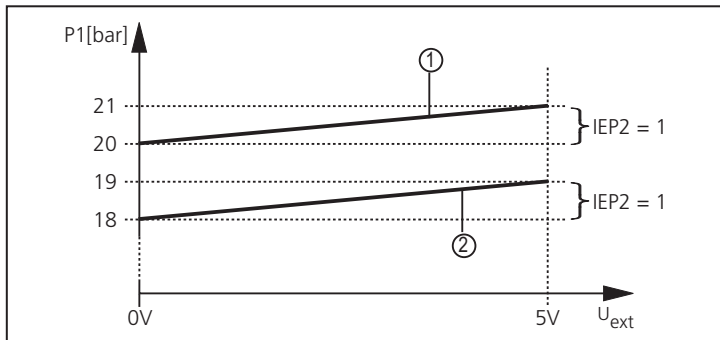

1: above the line output 1 is switched

2: below the line output 1 is switched

9.6.4 Selection of the preset value with comparison of target/actual value

Clamping pressure monitoring with fixed tolerance range

- A plc defines the preset value of a proportional valve. The clamping pressure of a workpiece is thus controlled.
- The pressure sensor detects the set pressure and compares it with the preset value.
- The sensor signals a value above (output 1) and below (output 2) the given tolerance range (± 1 bar).
- The preset values are between 0 and 60 bar; the control voltage is between 0 and 10 V.

Wiring diagram: → 4.2.1 example 3

SP1 = 1 OU1 = Hno	Output 1 is to switch (= ON) when the valve pressure is more than 1 bar above the preset pressure.
SP2 = -1 OU2 = Hnc	Output 2 is to switch (= ON) when the valve pressure is more than 1 bar below the preset pressure. Note: the hysteresis (rP2) has to be taken into account.
InP2 = U	The plc controls the valve pressure by a voltage signal.
ILP2 = 0 IHP2 = 10	The voltage range for the valve control is between 0 and 10 V.
IEP2 = 60	The plc changes the preset value on the proportional valve from 0 to 60 bar.

Display: Dmod = P1: applied pressure / actual value is displayed.

Dmod = P2: valve pressure / preset value is displayed.

Dmod = P1-2: difference between preset value and actual value is displayed.

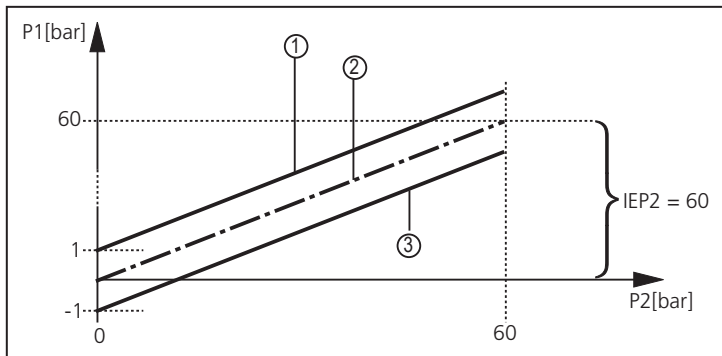

1: above the line output 1 is switched; 2: selection of the preset value (0 ... 60 bar)

3: below the line output 1 is switched

9.6.5 Selection of the preset value with comparison of target/actual value

Clamping pressure monitoring with variable tolerance range

As in the preceding example; with the following conditions:

- Preset values 0 ... 315 bar; control voltage 0 ... 10 V; basic tolerance = ± 1 bar; hysteresis error of the proportional valve +11 bar/-8 bar.

Wiring diagram: → 4.2.1 example 3

SP1 = 1 OU1 = Hno	Output 1 is to switch (= ON) when the valve pressure is more than 1 bar above the preset pressure.
SP2 = -1 OU2 = Hnc	Output 2 is to switch (= ON) when the valve pressure is more than 1 bar below the preset pressure. Note: the hysteresis (rP2) has to be taken into account.
InP2 = U	The plc controls the valve pressure by a voltage signal.
ILP2 = 0 IHP2 = 10	The voltage range for the valve control is between 0 and 10 V.
IEP2 = 315	The plc changes the preset value from 0 to 315bar (max. pressure).
LS1 = 11	Until the maximum pressure has been reached, the tolerance range changes by + 11 bar in a linear way.
LS2 = -8	Until the maximum pressure has been reached, the tolerance range changes by -8 bar in a linear way.

Display: Dmod = P1: applied pressure / actual value is displayed.

Dmod = P2: valve pressure / preset value is displayed.

Dmod = P1-2: difference between preset value and actual value is displayed.

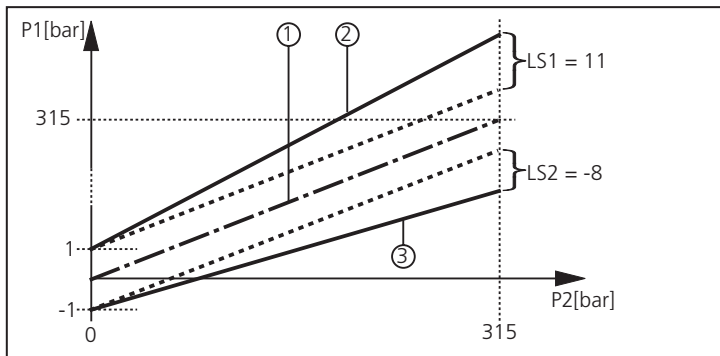

1: selection of the preset value (0 ... 315 bar); 2: shifting SP1; above the line output 1 is switched; 3: shifting SP2; below the line output 2 is switched.

9.6.6 Combination of two different physical quantities

Temperature-dependent pressure monitoring

- Temperature-dependent pressure monitoring
- The pressure sensor monitors a permissible maximum pressure and provides a switched signal when it is exceeded.
- The maximum permissible pressure decreases when the medium temperature rises: At 0°C it is 100 bar, at 100°C only 90 bar.
- The medium temperature is detected by a temperature sensor (measuring range 0 ... 200°C; analogue output 4 ... 20 mA). It transmits its analogue signal to the pressure sensor and is to reduce the switch point from 100 to 90 bar.

Wiring diagram: → 4.2.1 example 2

SP1 = 100 OU1 = Hno	Output 1 is to switch (= ON) when the maximum pressure exceeds the value of 100 bar.
InP2 = I	The temperature sensor provides a current signal.
ILP2 = 4	For a medium temperature of 0°C the temperature sensor provides 4 mA.
IHP2 = 12	For a medium temperature of 100°C the temperature sensor provides 12 mA
IEP2 = -10	The switch point of the pressure sensor is to be reduced by 10 bar when the medium temperature is 100°C.

Display: Dmod = P1: system pressure is displayed.

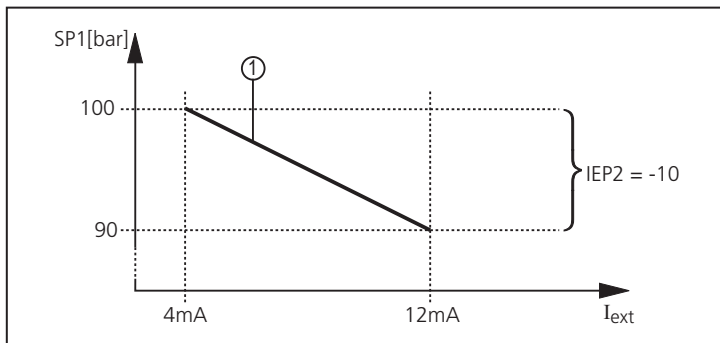

1: above the line output 1 is switched

10 Operation

After power on, the unit is in the Run mode (= normal operating mode). It carries out its measurement and evaluation functions and provides output signals according to the set parameters.

Operating indications → chapter 7 Operating and display elements.

10.1 Reading of the set parameters

- ▶ Press [Mode/Enter] until the requested parameter is displayed.
- ▶ Press [Set] briefly.
- > The unit displays the corresponding parameter value for about 15 s. After another 15 s the unit returns to the Run mode.

10.2 Fault indication

[OL]	Overload pressure (measuring range exceeded)
[UL]	Underload pressure (below measuring range)
[SC1]	Short circuit in OUT1*
[SC2]	Short circuit in OUT2*
[SC]	Short circuit in both outputs*

*The output concerned is switched off as long as the short circuit exists.
The messages SC1, SC2, SC, are shown even if the display is switched off.

11 Technical data and scale drawing

Technical data and scale drawing at www.ifm.com