

Operating instructions  
Mechatronic flow sensor  
**SBT6xx**

**GB**

11374788 / 01 04 / 2023



## Contents

1	Preliminary note . . . . .	3
1.1	Symbols used . . . . .	3
1.2	Warnings used . . . . .	3
2	Safety instructions . . . . .	4
3	Intended use . . . . .	5
3.1	Application area . . . . .	5
4	Function . . . . .	6
4.1	Analogue output . . . . .	6
5	Mounting . . . . .	7
5.1	Process connection . . . . .	7
5.2	Interference . . . . .	7
5.3	Mounting accessories . . . . .	8
5.4	Installation in case of water containing dirt . . . . .	8
6	Electrical connection . . . . .	9
7	Maintenance, repair and disposal . . . . .	10

# 1 Preliminary note



You will find instructions, technical data, approvals and further information using the QR code on the unit / packaging or at [www.ifm.com](http://www.ifm.com).

## 1.1 Symbols used

- ✓ Requirement
- ▶ Instructions
- ▷ Reaction, result
- [...] Designation of keys, buttons or indications
- Cross-reference
-  Important note  
Non-compliance may result in malfunction or interference.
-  Information  
Supplementary note

## 1.2 Warnings used

---

	<b>ATTENTION</b> Warning of damage to property
	<b>CAUTION</b> Warning of personal injury ▷ Slight reversible injuries may result.

---

## 2 Safety instructions

- The unit described is a subcomponent for integration into a system.
  - The system architect is responsible for the safety of the system.
  - The system architect undertakes to perform a risk assessment and to create documentation in accordance with legal and normative requirements to be provided to the operator and user of the system. This documentation must contain all necessary information and safety instructions for the operator, the user and, if applicable, for any service personnel authorised by the architect of the system.
- Read this document before setting up the product and keep it during the entire service life.
- The product must be suitable for the corresponding applications and environmental conditions without any restrictions.
- Only use the product for its intended purpose (→ Intended use).
- Only use the product for permissible media.
- If the operating instructions or the technical data are not adhered to, personal injury and/or damage to property may occur.
- The manufacturer assumes no liability or warranty for any consequences caused by tampering with the product or incorrect use by the operator.
- Installation, electrical connection, set-up, operation and maintenance of the product must be carried out by qualified personnel authorised by the machine operator.
- Protect units and cables against damage.

## 3 Intended use

The unit monitors liquid media.

The device detects the volume flow (flow rate/time) and outputs an analogue signal that is proportional to the process value.

### 3.1 Application area

- Water
- Glycol solutions
- Industrial oils
- Coolants



If the cable length exceeds 30 m or if used outside buildings, there is a risk of overvoltage pulses from external sources. We recommend to use the unit in protected operating environments and to limit overvoltage pulses to max. 500 V.

#### ATTENTION

Frost formation of the medium.

▷ The sensor may be damaged.

▶ Ensure that the medium in the sensor does not freeze during operation and transport.

## 4 Function

The unit detects the flow according to the principle of differential pressure by means of a permanent magnet and a measuring cell.

### 4.1 Analogue output

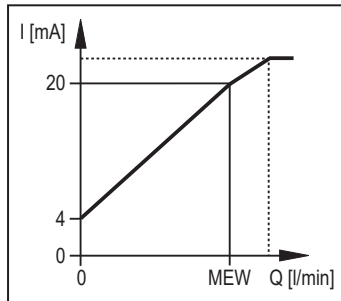

Fig. 1: Analogue output (water 20 °C)

The analogue signal for water is linear from 4 mA (= no flow) to 20 mA (= final value of the measuring range, VMR).

If the measured value is above the final value of the measuring range, a current signal of > 20 mA is output.

## 5 Mounting



### CAUTION

During installation or in case of a fault (e.g. housing damage) media under high pressure or hot media can leak from the system.

- ▷ Risk of injury caused by pressure or burns.
- ▶ Ensure that the system is free of pressure during installation.
- ▶ Ensure that no media can leak at the mounting location during installation.
- ▶ Equip the unit with suitable protection (e.g. cover) to avoid hazard to personnel from leaking media.

### 5.1 Process connection

- ▶ Avoid major changes of cross section on the inlet side.
- ▶ Fit the unit in the pipe in accordance with the flow direction (arrow) and tighten at the spanner flats.



Do not clamp the housing in a vice.

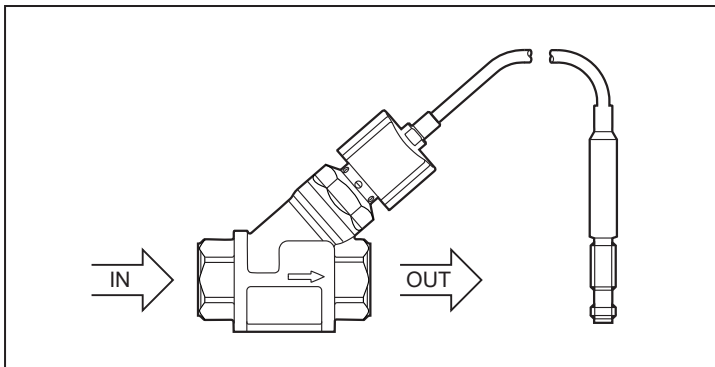

Fig. 2: Process connection

IN: inlet  
 OUT: outlet



Calming sections on the sensor's inlet or outlet side are not necessary.



The sensor can also prevent backflow.

### 5.2 Interference

- ▶ The following minimum distances must be adhered to:

Distance between the sensor and ferromagnetic materials	≥ 30 mm *
Distance between the sensor and constant / alternating fields	≥ 500 mm
Distance between the sensor axes for side-by-side installation	≥ 50 mm

\* The pipe may consist of ferromagnetic material.

### 5.3 Mounting accessories

- ▶ If necessary, fasten the unit on the mounting plate (not supplied) from underneath:

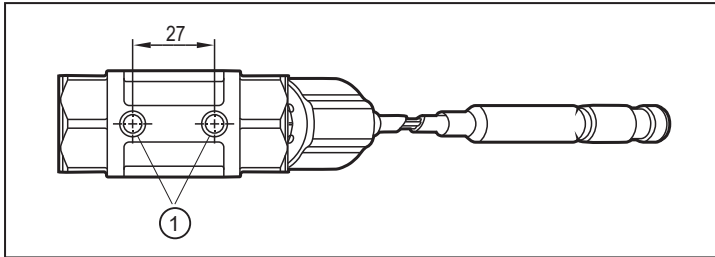

Fig. 3: Installation with mounting plate

- 1: threaded hole M8 (depth 6 mm) on the bottom side of the unit



Information about available accessories at [www.ifm.com](http://www.ifm.com)

### 5.4 Installation in case of water containing dirt

- ▶ Use a 200-micron filter in front of the inlet (IN).
- ▶ Install sensor horizontally.
- ▶ Adhere to the inclination angle to the horizontal axis:

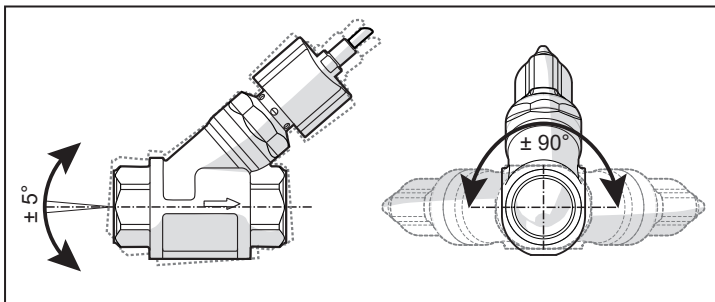

Fig. 4: Alignment in case of water containing dirt



In clean medium, installation in vertical pipes is also possible.



## 6 Electrical connection



The unit must be connected by a qualified electrician.

Observe the national and international regulations for the installation of electrical equipment.

Voltage supply according to SELV, PELV.

► Disconnect power.

► Connect the unit as follows:

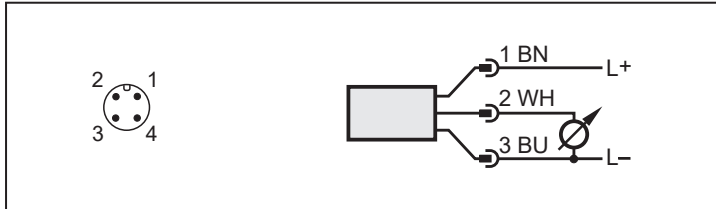

Fig. 5: Wiring diagram (colours in accordance with DIN EN60947-5-2)

BN: Brown

WH: White

BU: Blue



Information on available sockets see: [www.ifm.com](http://www.ifm.com).

## **7 Maintenance, repair and disposal**

The operation of the unit is maintenance-free.

Only the manufacturer is allowed to repair the unit.

- ▶ After use dispose of the device in an environmentally friendly way in accordance with the applicable national regulations.