

ifm electronic



Mounting and installation instructions

Positioning of the ID tags  
to the read/write head

UK

Installation of the ID tags in/on metal

**efector190<sup>®</sup>**

**DTA10x and E803xx**

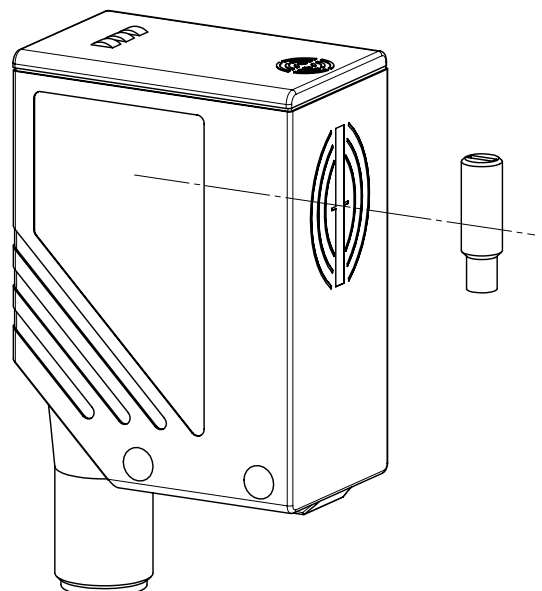

704061 / 01 04 / 2010

## Contents

1 Preliminary note . . . . .	2
1.1 Scope . . . . .	2
1.2 Symbols used . . . . .	3
1.3 Additional information . . . . .	3
2 General installation instructions . . . . .	3
3 ID tag flush mounted in metal . . . . .	4
3.1 Dimensions of the recess . . . . .	4
3.2 Read/write distances for flush installation in metal . . . . .	5
3.2.1 E80311 . . . . .	5
3.2.2 E80312 . . . . .	5
3.2.3 E80317 . . . . .	6
3.2.4 E80318 . . . . .	6
3.2.5 E80319 . . . . .	7
3.2.6 E80322 . . . . .	7
4 ID tag at a distance from the metal . . . . .	8
4.1 Installation dimensions . . . . .	8
4.2 Read/write distances at a distance from the metal . . . . .	9
4.2.1 E80311 . . . . .	9
4.2.2 E80301, E80312...E80322 . . . . .	9

## 1 Preliminary note

### 1.1 Scope

This document describes the ideal positioning of the ID tags (RFID transponders) E803xx to the read/write heads DTA10x as well as the read/write distances that can be obtained when the ID tags are installed in/on metal.

DTA100: DTSLF AARWASUS01 (= read/write head)

DTA101: DTSLF AAROASUS01 (= read head)

### 1.2 Symbols used

▶ Instruction

→ Cross-reference



Important note

Non-compliance can result in malfunctions or interference.



Information

Supplementary note

### 1.3 Additional information

Technical data sheets:

[www.ifm.com](http://www.ifm.com) → Data sheet direct → e.g. E80312

Installation instructions DTS125:

[www.ifm.com](http://www.ifm.com) → Data sheet direct → e.g. DTA100 → Additional data

## 2 General installation instructions



If the ID tags are mounted in/on metal, the read/write distance is reduced.

- ▶ Install the ID tags centered to the antenna symbol on the front or upper side of the read/write head (attribution of the ID tags see below).
- ▶ Ensure in dynamic applications that the ID tags pass the middle of the antenna symbol.

UK

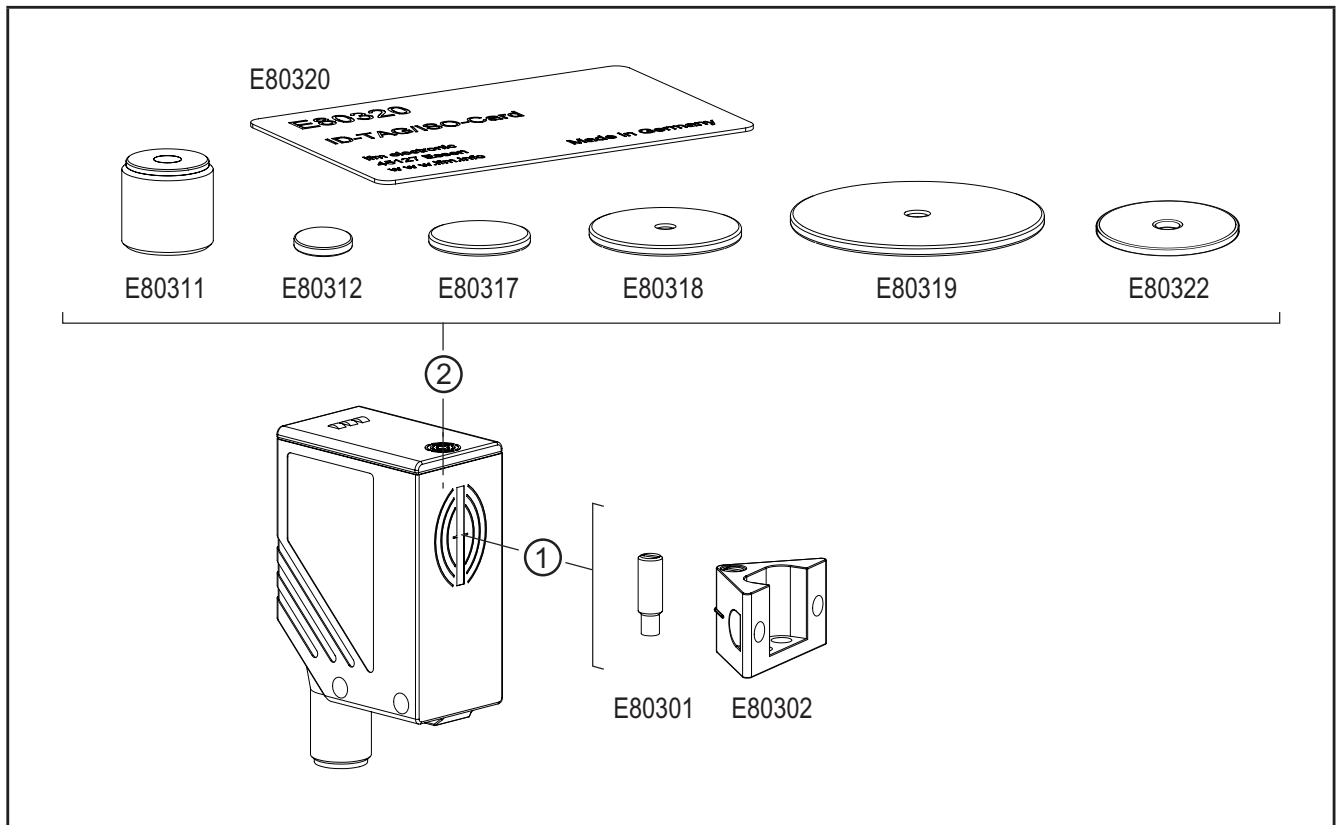

1: Positioning front side

2: Positioning overhead

Marking middle of the antenna = middle of the ID tag

### 3 ID tag flush mounted in metal

- ▶ Install the ID tag flush and centered in a circular recess. Take into account the diameter and the minimum depth of the recess.
- ▶ Fill the space between ID tag and metal carrier with a non-metallic filling compound (e.g. glue or cast resin).

#### 3.1 Dimensions of the recess

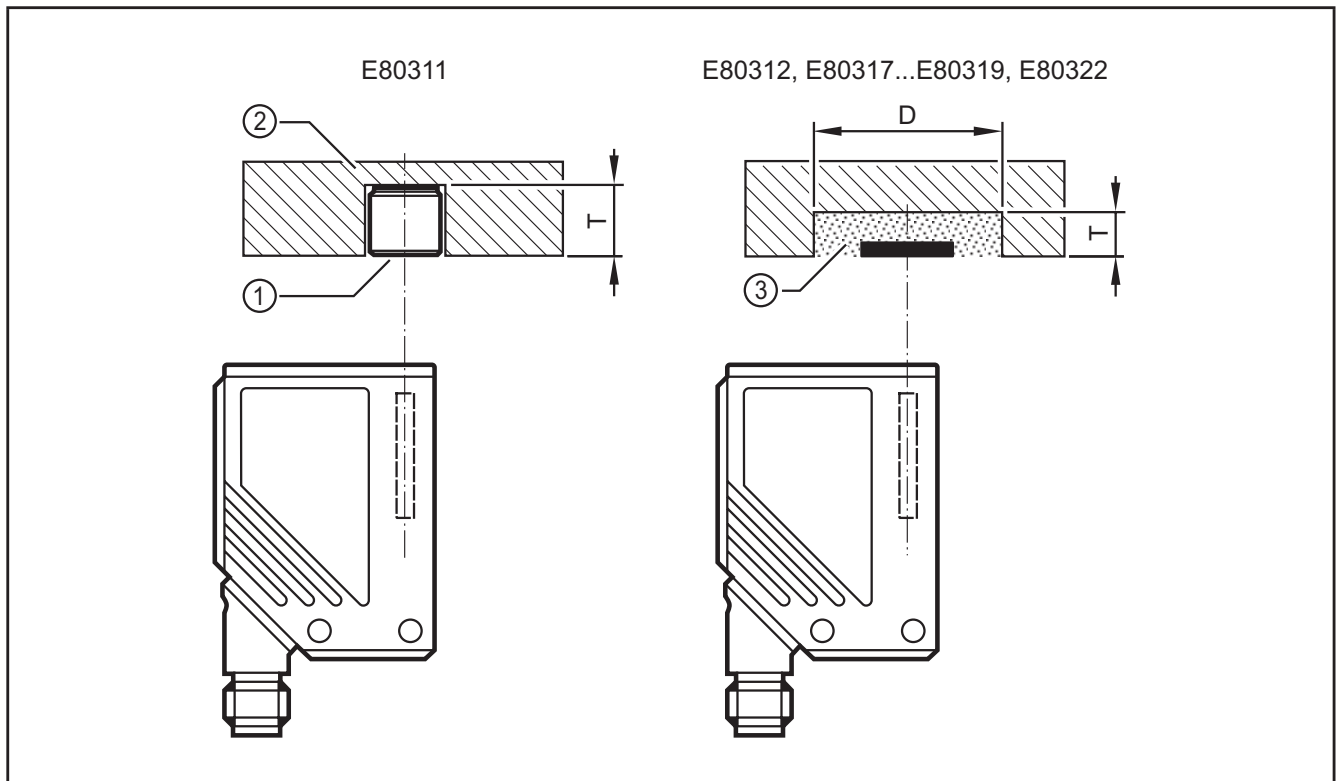

- 1: Type label of the ID points towards the read/write head  
 2: Metal  
 3: non-metallic filling compound

ID tag	Diameter of the recess D [mm]	Depth T [mm]
E80311*	M18	≤ 18 (18 = flush)
E80312	≥ 15	≥ 6
E80317	≥ 25	≥ 6
E80318	≥ 35	≥ 6
E80319	≥ 55	≥ 8
E80322	≥ 32	≥ 6

\*) ID tag in threaded housing for screw mounting

## 3.2 Read/write distances for flush installation in metal

### 3.2.1 E80311

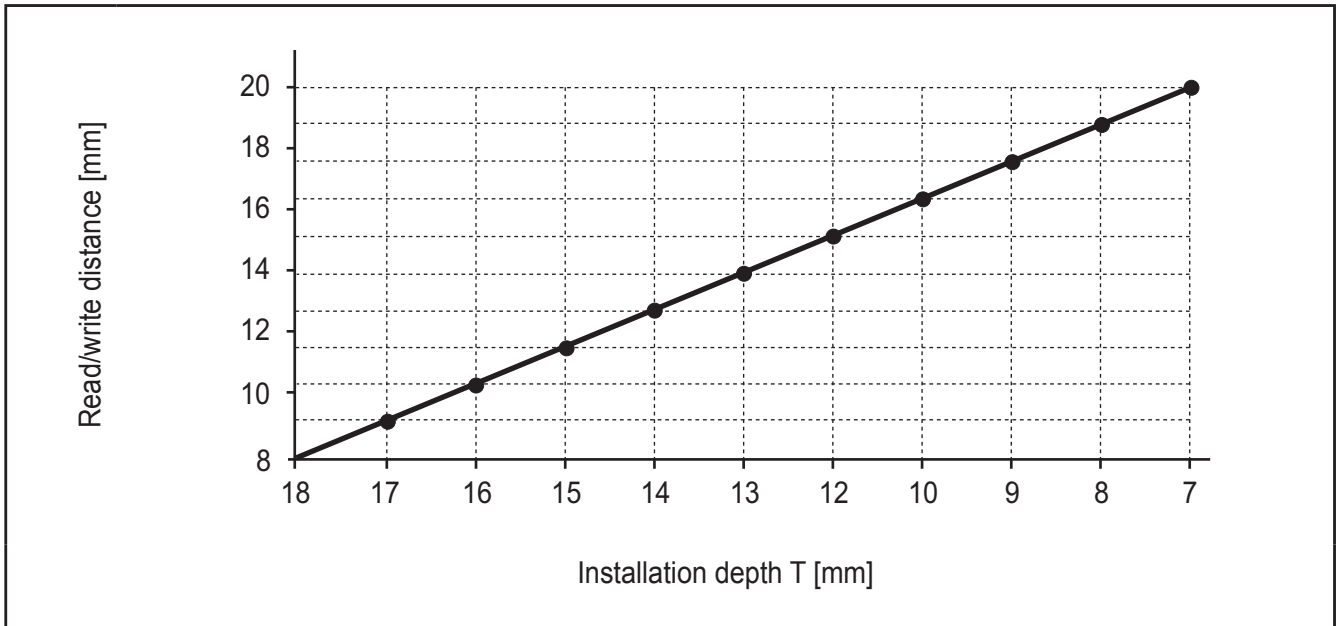

Installation depth T = 18 mm = flush installation

### 3.2.2 E80312

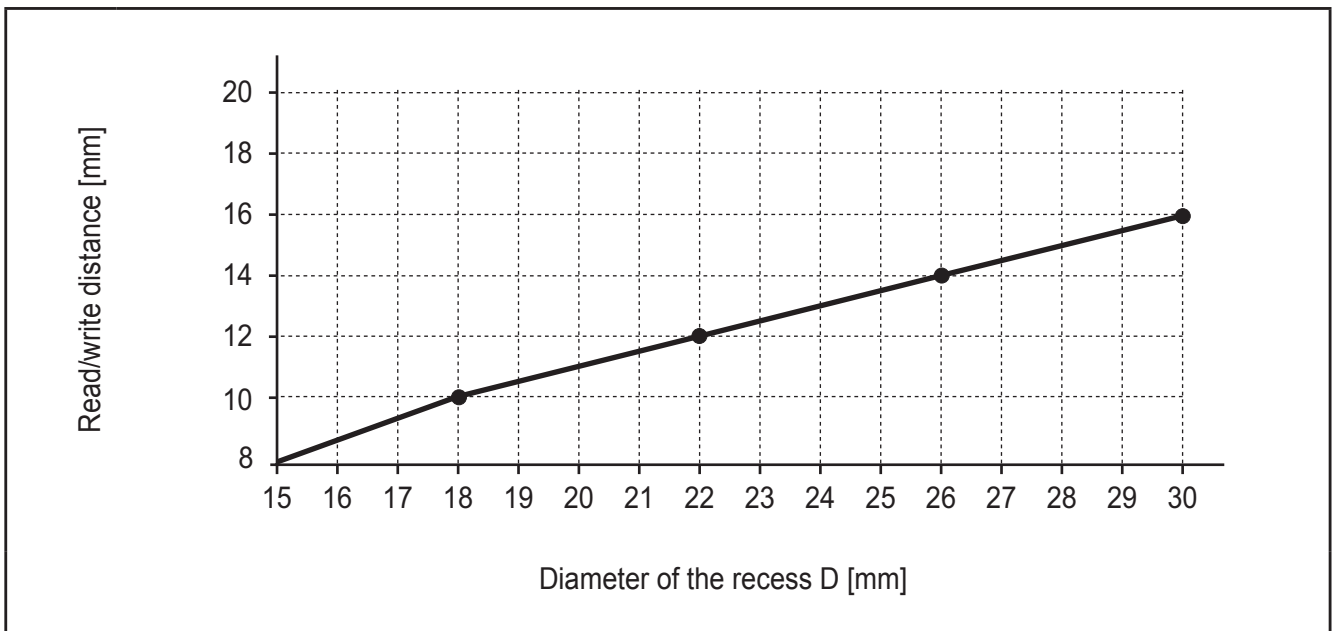

UK

### 3.2.3 E80317

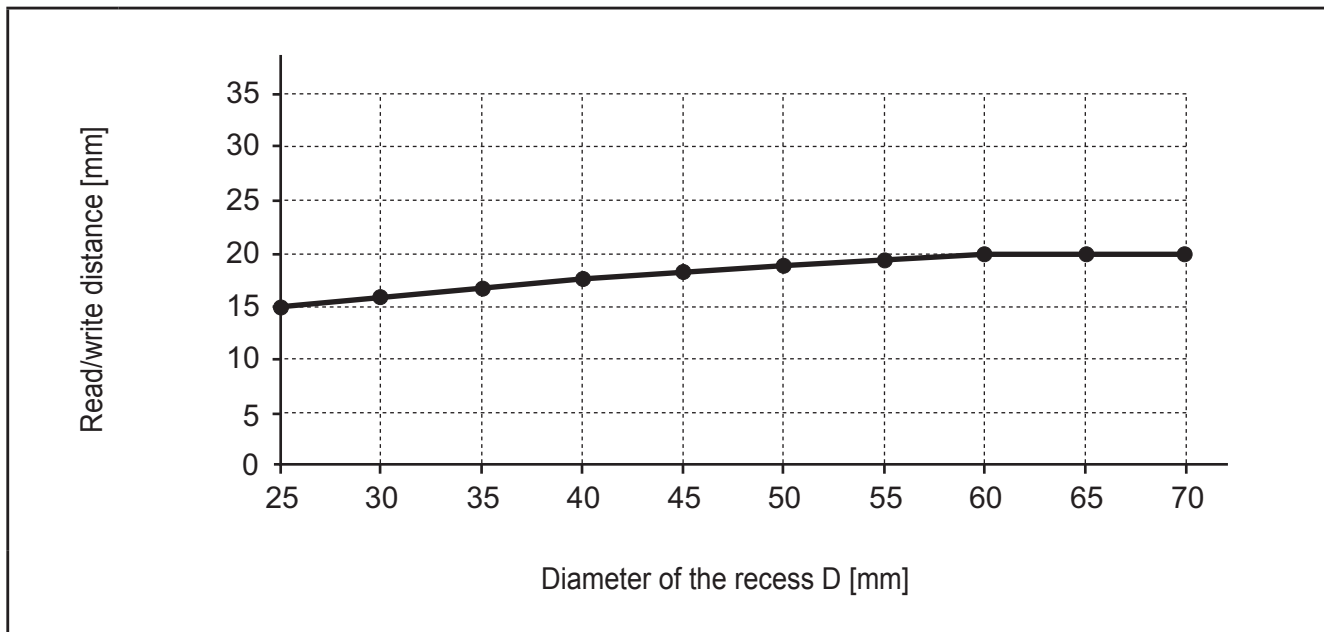

### 3.2.4 E80318

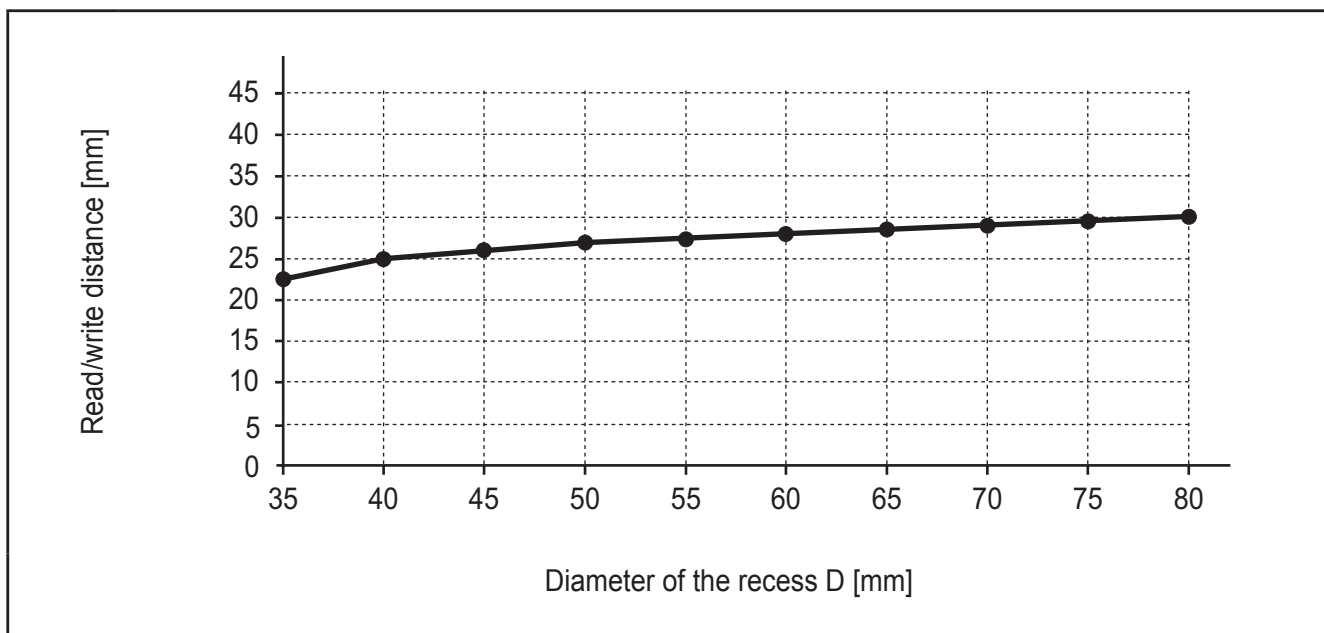

### 3.2.5 E80319

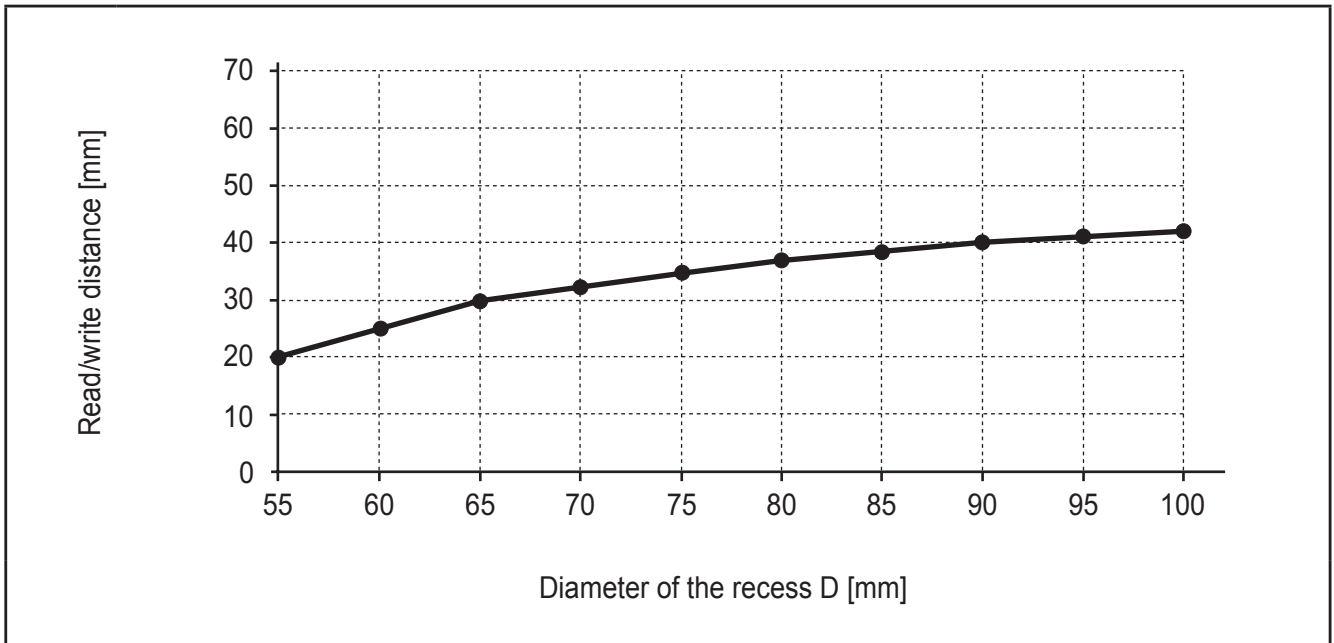

UK

### 3.2.6 E80322

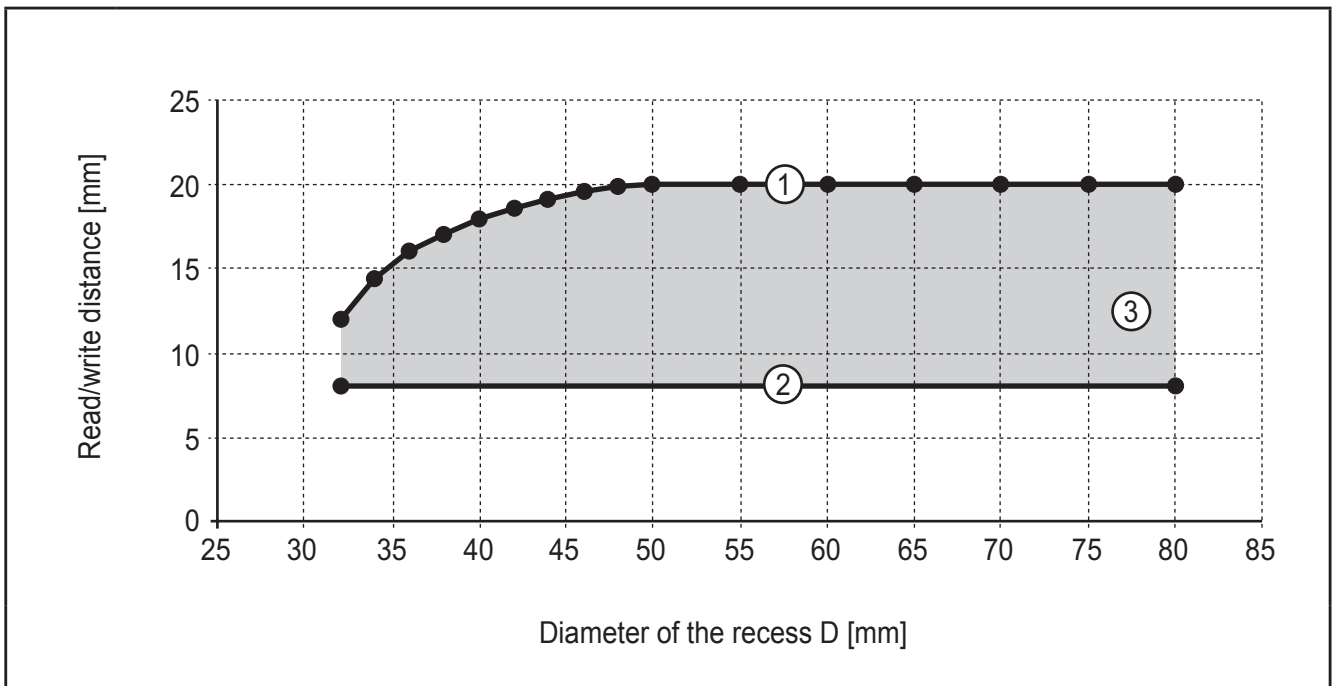

- 1: Upper limit
- 2: Lower limit
- 3: Read/write area

## 4 ID tag at a distance from the metal

- ▶ Mount a non-metallic spacer between ID tag and metal carrier.

### 4.1 Installation dimensions

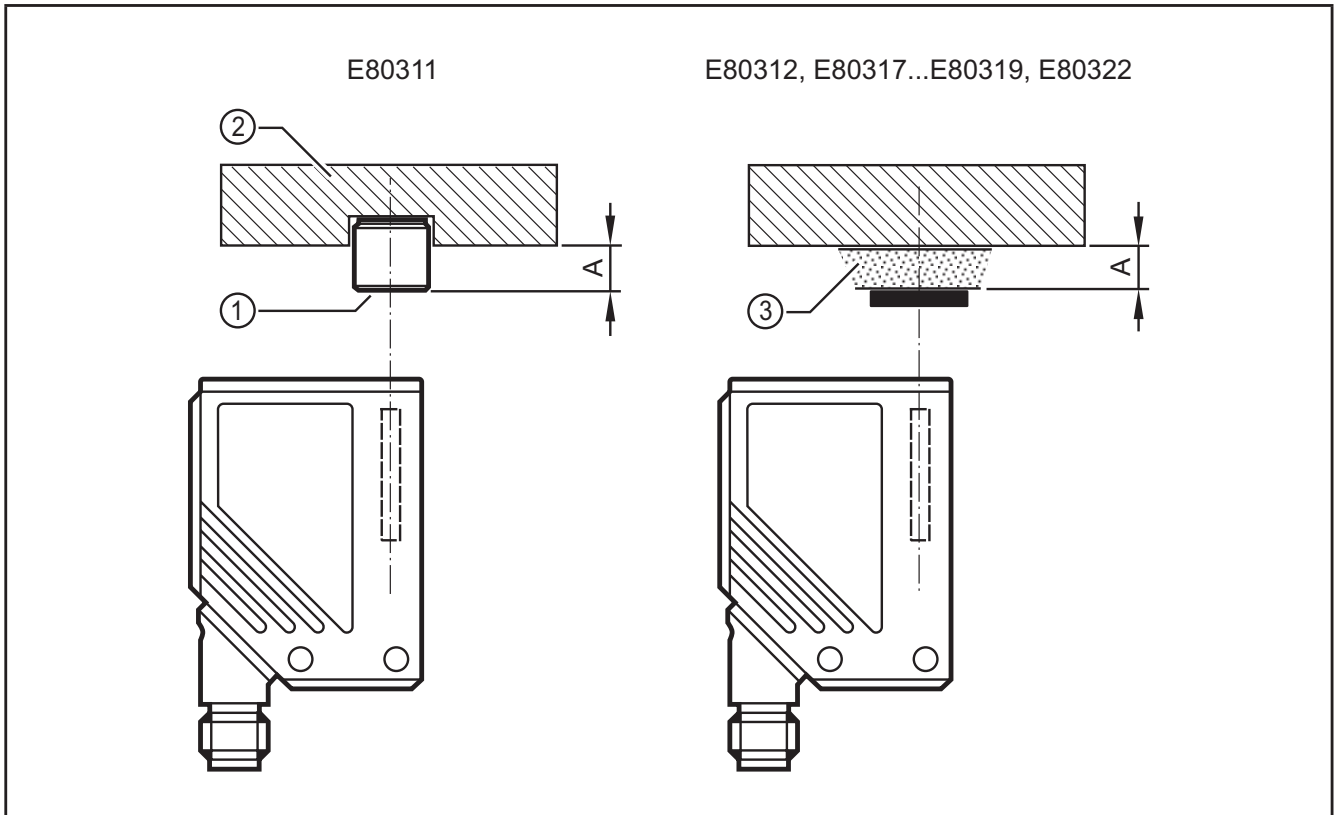

- 1: Type label of the ID points towards the read/write head
- 2: Metal
- 3: non-metallic spacer



## 4.2 Read/write distances at a distance from the metal

### 4.2.1 E80311

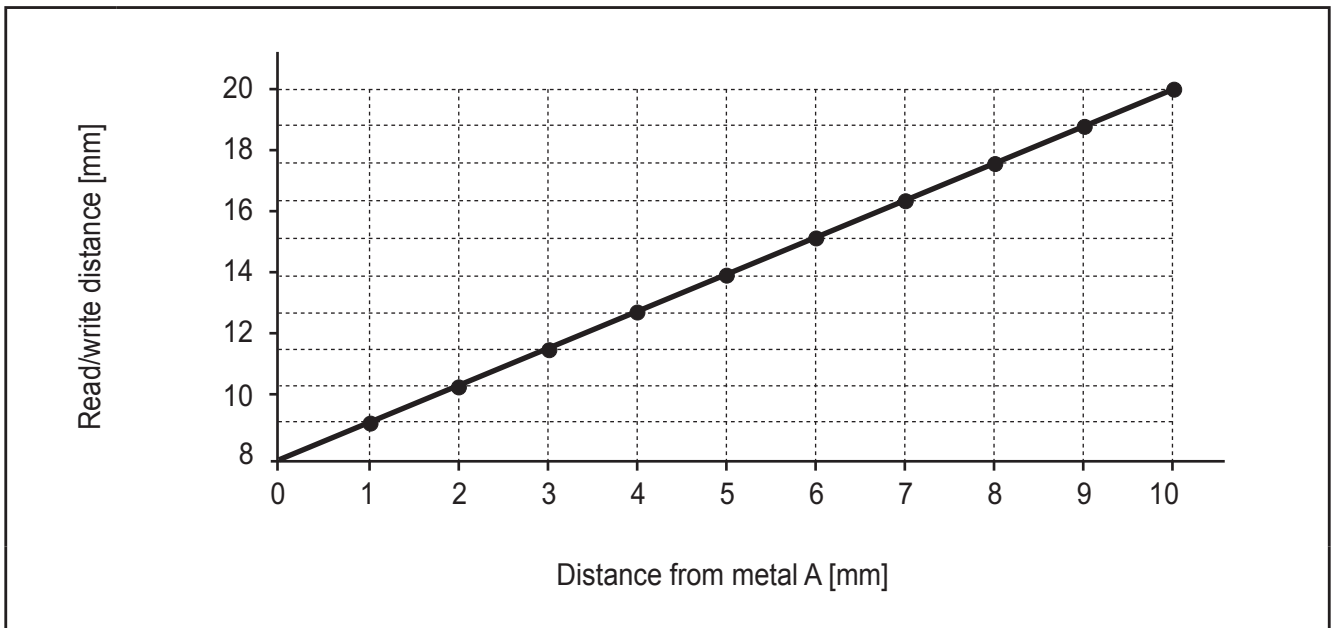

Distance A = 0 mm = flush installation

### 4.2.2 E80301, E80312...E80322

ID tag	Distance from metal A [mm]		
	5	10	15
E80301	20	20	20
E80312	17	20	20
E80317	20	23	26
E80318	30	33	36
E80319	35	45	50
E80322	32	35	38

Read/write distances in mm

UK