

Operating instructions
RF-identification system
DTI600
Read/write head

GB

11476236 / 00 09 / 2022



Contents

| | | |
|--------|--|----|
| 1 | Preliminary note | 3 |
| 1.1 | Symbols used | 3 |
| 1.2 | Warnings used | 3 |
| 1.3 | Legal and copyright information | 3 |
| 2 | Safety instructions | 4 |
| 3 | Intended use | 5 |
| 4 | Items supplied | 6 |
| 5 | Function | 7 |
| 5.1 | ID tags | 7 |
| 5.2 | Detection range with E80384 | 7 |
| 5.3 | Device overview | 7 |
| 5.4 | IO-Link | 8 |
| 6 | Installation | 9 |
| 6.1 | Notes on the unit installation | 9 |
| 6.2 | Avoiding interference | 9 |
| 6.3 | Mechanical design | 9 |
| 6.4 | Mounting options | 9 |
| 6.4.1 | Installation with angle bracket E80335 | 10 |
| 6.4.2 | Installation with mounting device E80336 | 10 |
| 6.4.3 | Installation with fixing bars E80337 | 11 |
| 6.5 | Mounting distances | 11 |
| 6.6 | Positioning of the ID tags | 12 |
| 7 | Electrical connection | 13 |
| 7.1 | Wiring | 13 |
| 8 | Operating and display elements | 14 |
| 9 | Parameter setting | 15 |
| 9.1 | Parameter | 15 |
| 9.1.1 | Data block size | 15 |
| 9.1.2 | Data alignment | 15 |
| 9.1.3 | Data hold time | 15 |
| 9.1.4 | Address for automatic read/write | 16 |
| 9.1.5 | Data length for automatic read/write | 16 |
| 9.2 | Status bits | 16 |
| 10 | Operation | 18 |
| 10.1 | Deactivate internal antenna | 18 |
| 10.2 | Operating mode Read UID | 18 |
| 10.3 | Operating mode Auto read data | 19 |
| 10.4 | Operating mode Auto write data | 20 |
| 10.5 | Operating mode Read data | 21 |
| 10.5.1 | Example successful reading of data | 23 |
| 10.5.2 | Example unsuccessful reading of data | 24 |
| 10.6 | Operating mode Write data | 25 |
| 10.6.1 | Example successful writing of data | 26 |
| 10.6.2 | Example unsuccessful writing of data | 27 |
| 10.7 | Error values in the process data input | 29 |
| 11 | Maintenance, repair and disposal | 30 |
| 12 | Approvals/standards | 31 |
| | Glossary | 32 |

1 Preliminary note

You will find instructions, technical data, approvals and further information using the QR code on the unit / packaging or at www.ifm.com.

1.1 Symbols used

- ✓ Requirement
- ▶ Instructions
- ▷ Reaction, result
- [...] Designation of keys, buttons or indications
- Cross-reference
-  Important note
Non-compliance may result in malfunction or interference.
-  Information
Supplementary note

1.2 Warnings used

ATTENTION

Warning of damage to property

1.3 Legal and copyright information

© All rights reserved by ifm electronic gmbh. No part of these instructions may be reproduced and used without the consent of ifm electronic gmbh.

All product names, pictures, companies or other brands used on our pages are the property of the respective rights owners.

2 Safety instructions

General

- The unit described is a subcomponent for integration into a system.
 - The system architect is responsible for the safety of the system.
 - The system architect undertakes to perform a risk assessment and to create documentation in accordance with legal and normative requirements to be provided to the operator and user of the system. This documentation must contain all necessary information and safety instructions for the operator, the user and, if applicable, for any service personnel authorised by the architect of the system.
- Read this document before setting up the product and keep it during the entire service life.
- The product must be suitable for the corresponding applications and environmental conditions without any restrictions.
- Only use the product for its intended purpose (→ → Intended use).
- If the operating instructions or the technical data are not adhered to, personal injury and/or damage to property may occur.
- The manufacturer assumes no liability or warranty for any consequences caused by tampering with the product or incorrect use by the operator.
- Installation, electrical connection, set-up, operation and maintenance of the product must be carried out by qualified personnel authorised by the machine operator.
- Protect units and cables against damage.

Radio equipment

In general, radio equipment must not be used in the vicinity of petrol stations, fuel depots, chemical plants or blasting operations.

- ▶ Do not transport and store any flammable gases, liquids or explosive substances near the unit.

Interference of electronic and medical devices

Operation can affect the function of electronic devices that are not correctly shielded.

- ▶ Disconnect the device in the vicinity of medical equipment.
- ▶ Contact the manufacturer of the corresponding device in case of any interference.

3 Intended use

The read/write head reads and writes **ID tags** without contact.

The data is made available as process data via the **IO-Link** interface.

4 Items supplied

- Read/write head



The device is supplied without installation and connection accessories.

Available accessories: www.ifm.com.

The optimum function is not ensured when using components from other manufacturers.

5 Function

5.1 ID tags

The **ID tags** are passively operated without a battery. The energy required for operation is provided by the read/write head.

The energy is provided via an inductive coupling. The integrated antenna coil in the read/write head generates a magnetic field which partly penetrates the antenna coil of the ID tag. A voltage is generated by induction that supplies the data carrier with energy.

The device supports ID tags according to ISO 15693.

5.2 Detection range with E80384

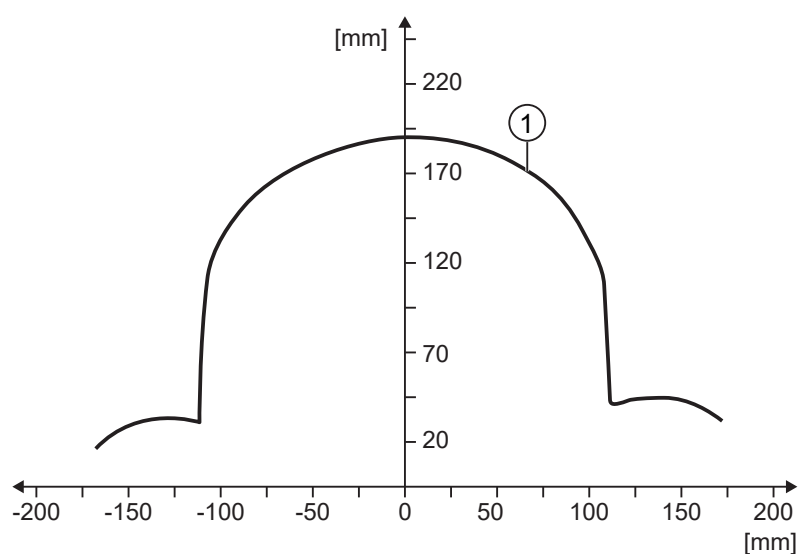

Fig. 1: Propagation field
1 Detection zone



The indications refer to static write operations and to the installation of the device and the ID tag in a non-metal environment.

5.3 Device overview

DTI600

| | | |
|--|-------------------|---------------------|
| | Article number: | DTI600 |
| | Function: | RFID compact device |
| | Type designation: | DTRHF HLRWIOUS03 |
| | Type: | Rectangular |

5.4 IO-Link



This unit has an IO-Link communication interface which enables direct access to process and diagnostic data. In addition it is possible to set the parameters of the unit while it is in operation. Operation of the unit via the IO-Link interface requires an IO-Link master.

With a PC, suitable IO-Link software and an IO-Link adapter cable, communication is possible while the system is not in operation.

The **IODD** required to configure the unit is available at www.ifm.com.

6 Installation

6.1 Notes on the unit installation

-  When mounting several RFID units adhere to the minimum distances between the systems.
-  Flush mounting of a read/write head in metal reduces the read/write distance.
-  Device performance can be affected if positioned in the immediate vicinity of powerful HF emission sources such as welding transformers or converters.

6.2 Avoiding interference

The device generates a modulated electrical field with a frequency of 13.56 MHz.

Avoid interference with data communication:

- ▶ Do not operate any devices in the vicinity that use the same frequency band.
- ▷ Such devices are for example frequency converters and switched-mode power supplies.

If there are other devices in the same frequency band in the vicinity:

- ▶ The mounting distances between the devices should be as large as possible.
- ▶ Use the devices in alternating operation.
- ▶ Switch the HF field of the device on/off.

6.3 Mechanical design

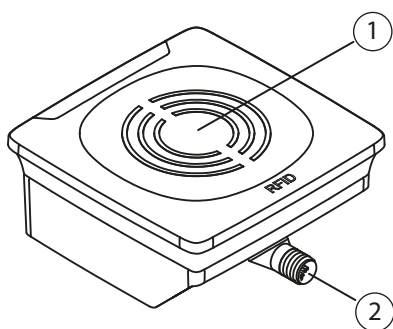

1 Sensing face

2 Connections (can be rotated by 270°)

6.4 Mounting options

-  The device can be mounted without the accessories.
 - ▶ For installation, please use the threaded sleeves on the back of the device.
 - ▷ The required screws are not supplied with the device.

6.4.1 Installation with angle bracket E80335

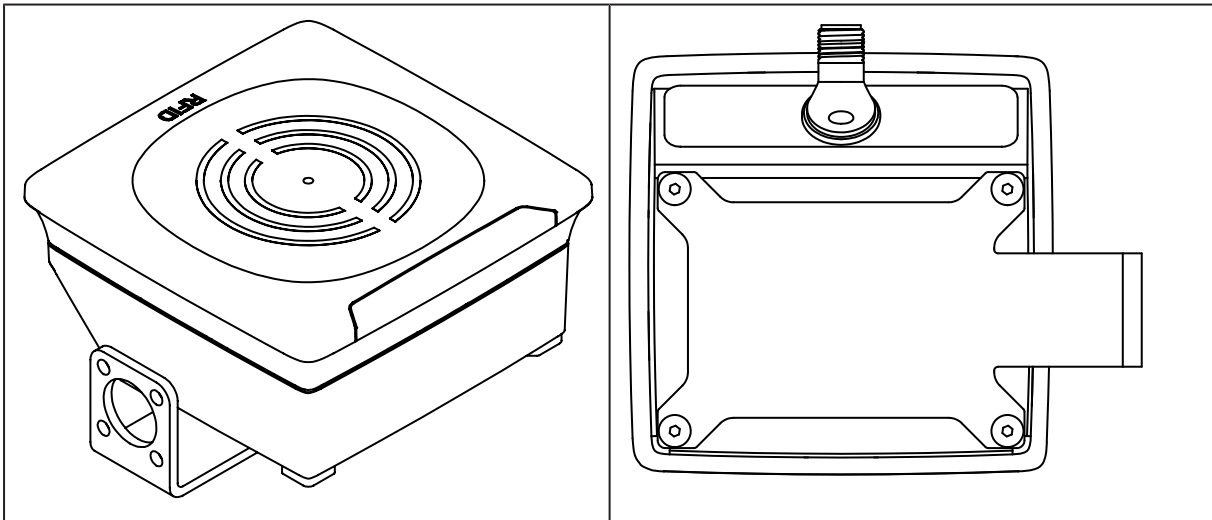

6.4.2 Installation with mounting device E80336

The mounting device is used to mount the unit on a clamp. Compatible clamps:

- E21110 with a rod diameter of 12 mm
- E20795 with a rod diameter of 14 mm
- E21109 with a rod diameter of 14 mm

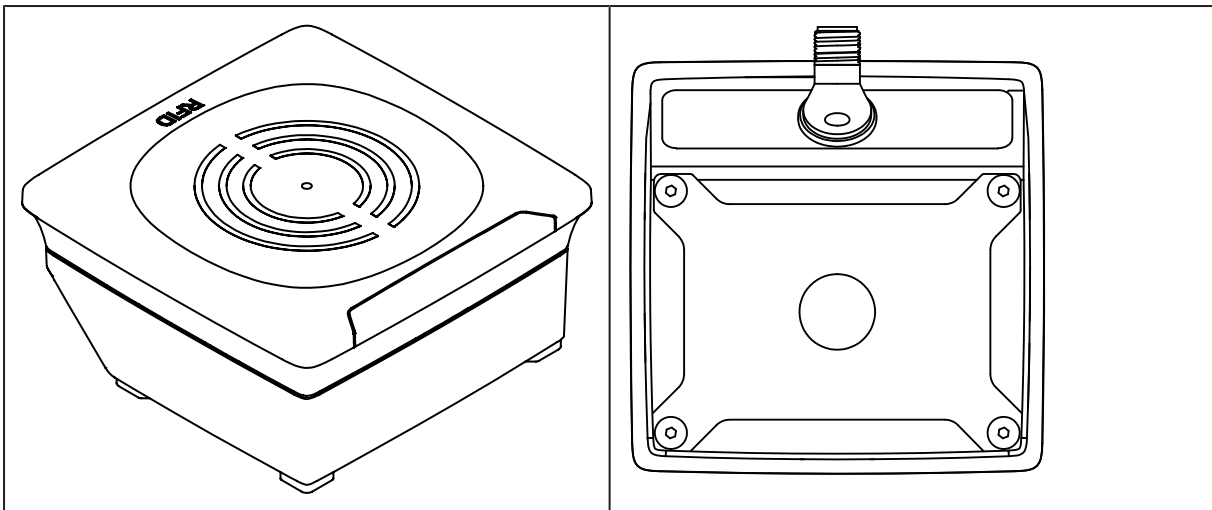

6.4.3 Installation with fixing bars E80337

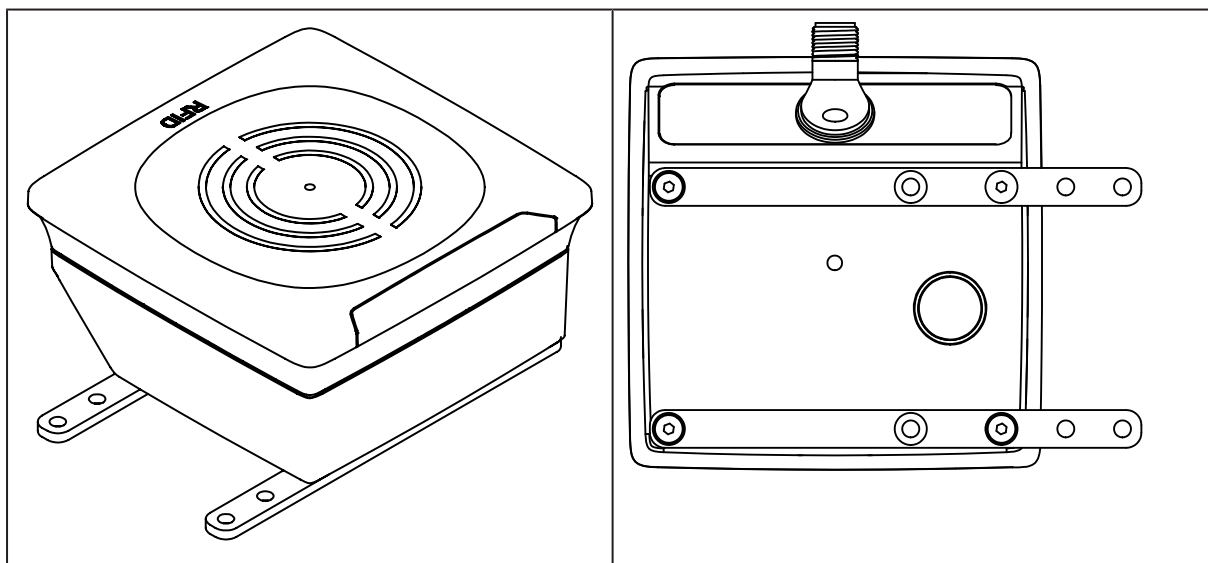

6.5 Mounting distances

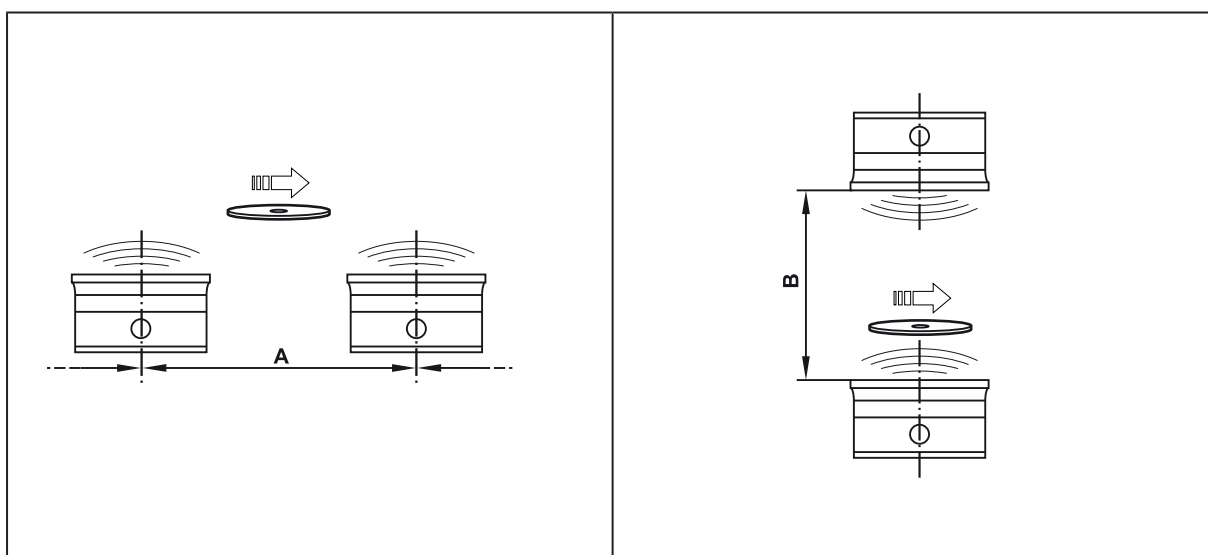

| Operating mode | Distance side (A) | Distance front (B) |
|-------------------------|-------------------|--------------------|
| For reading and writing | >0.6 m | >0.4 m |



Interference in data communication is avoided if there are no other RFID UHF devices in the vicinity. If there are other RFID UHF devices in the vicinity:

- ▶ The mounting distances between the devices should be as large as possible.
- ▶ Use the RSSI filter.
- ▶ Use the devices in alternating operation.
- ▶ Switch the HF field of the device on/off.

6.6 Positioning of the ID tags

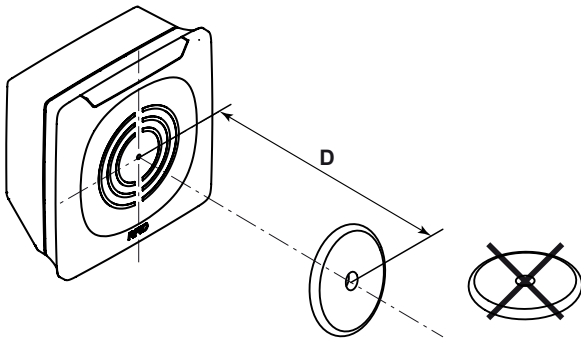

Fig. 2: Position the ID tag

- ▶ Align the ID tag on the antenna central axis.
- ▷ The distance “D” is indicated in the data sheet.



ID tags are also detected on the back of the device. To avoid this:

- ▶ Use the RSSI filter.

7 Electrical connection



The device must be connected by a qualified electrician.

Device of protection class III (PC III).

The electrical supply must only be made via PELV/SELV circuits.

- ▶ Disconnect power before connecting the device.

ATTENTION

The IP rating indicated in the data sheet is only guaranteed if the M12 connectors are firmly screwed. The device can be damaged by insufficiently tightened M12 connectors.

- ▶ Screw the M12 connector to the device applying 1 to 1.5 Nm.

7.1 Wiring

- ▶ Connect the device to an IO-Link master using a M12 connection cable.

- ▷ Voltage is supplied via the IO-Link master.

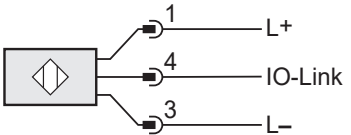
| Pin assignment | Wiring |
|--|---|
|  |  |

8 Operating and display elements

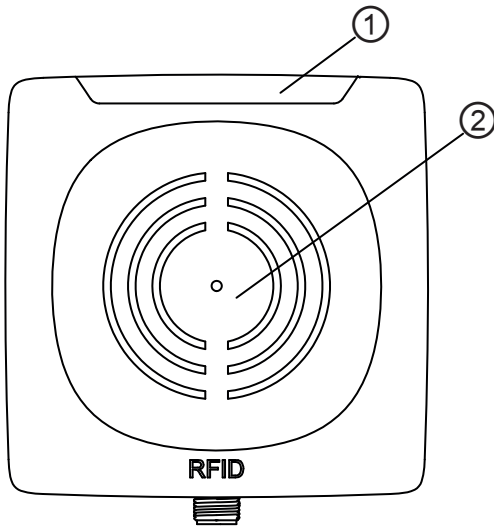

Fig. 3: Operating and display elements

1 LEDs

2 Sensing face

| LED | State | Description |
|------------------|----------------------|---|
| green | On | Operating voltage OK |
| | Off | Operating voltage missing |
| | Flashing slowly | deactivated |
| yellow | On (permanently) | ID tag detected |
| | On (pulse) | ID tag read/written successfully |
| | Flashing quickly | Error when reading/writing on ID tag |
| | Off | <ul style="list-style-type: none"> • no ID tag in the field • faulty ID tag in the field • invalid ID tag in the field |
| green and yellow | Flashing alternately | Error in communication or device fault |

9 Parameter setting

The parameters of the device are set using a software via IO-Link (for example ifm moneo configure SA).



More information can be found in the IODD of the unit: www.ifm.com

9.1 Parameter

9.1.1 Data block size

The memory area of an ID tag is organised in data blocks. The parameter specifies the size of a data block. The set value must correspond with the value of the ID tag indicated in the data sheet.

The following values are permissible:

4,8,16 and 32 bytes per block.

The data block size is only required for the internal data processing in the device. The user can access the process data images byte by byte on the memory area of the ID tag.

9.1.2 Data alignment

The parameter sets the order of the data in a data block of the ID tag.

Example

For an ID tag with block size 4 bytes the data can be ordered as in the tables:

| Data block 0 | | | | Data block 1 | |
|--------------|--------|--------|--------|--------------|-----|
| Byte 3 | Byte 2 | Byte 1 | Byte 0 | Byte 3 | ... |

Tab. 1: Normal order

| Data block 0 | | | | Data block 1 | |
|--------------|--------|--------|--------|--------------|-----|
| Byte 0 | Byte 1 | Byte 2 | Byte 3 | Byte 0 | ... |

Tab. 2: Reversed order

9.1.3 Data hold time

The data hold time indicates the time during which the data of the process data input image can be held constant. Depending on the operating mode, this concerns

- the UID,
- the "Tag present" bit,
- the data in Auto read and Auto write mode.

The parameter "Data hold time" does not influence data transfer in the operating modes "Read data" and "Write data".

Example

When the data hold time is set to 500 ms, the UID and the "Tag present" bit are transferred for min. 500 ms via IO-Link.

This also applies if the ID tag is no longer within the range of the device.

9.1.4 Address for automatic read/write

The parameter "Address for automatic read/write" sets the start address of the memory area that is accessed in the operating modes "Auto read" and "Auto write".

The address is provided in bytes.

In the operating modes "Auto read" and "Auto write" the device reads and writes a specified number of data of the ID tag automatically.

The addressed memory area must be within the available memory area of the ID tag:

Auto Read and Write Address +

Auto Read and Write Data Length ≤

Number of available bytes on the ID tag

The number of available bytes is indicated in the data sheet of the ID tag.

9.1.5 Data length for automatic read/write

The parameter "Data length for automatic read/write" sets the length of the memory area that is read and written.

The length is indicated in bytes. The minimum length is 1 byte and the maximum length is 29 bytes.

In the operating modes "Auto read" and "Auto write" the device reads and writes a specified number of data of the ID tag automatically.

The addressed memory area must be within the available memory area of the ID tag:

Auto Read and Write Address +

Auto Read and Write Data Length ≤

Number of available bytes on the ID tag

The number of available bytes is indicated in the data sheet of the ID tag.

9.2 Status bits

| Process data input | | | | | | | | |
|--------------------|---|---|---|---|----------------------|-------------|---------|-----------------------|
| Bit | 7 | 6 | 5 | 4 | 3 | 2 | 1 | 0 |
| Name | | | | | Antenna de-activated | Tag present | Cmd End | Cmd Start Acknowledge |

| Process data output | | | | | | | | |
|---------------------|---|---|---|---|------------------------|---|---|-----------|
| Bit | 7 | 6 | 5 | 4 | 3 | 2 | 1 | 0 |
| Name | | | | | Cmd Antenna deactivate | | | Cmd Start |

| Status bit | Value | Description |
|---------------------|-------|---|
| Antenna deactivated | 0 | Antenna activated, device ready to receive |
| | 1 | Antenna deactivated, device not ready to receive |
| Tag present | 0 | No ID tag in the range of the device |
| | 1 | ID tag detected |
| Cmd End | 0 | Read or write operation not yet started or active |

| Status bit | Value | Description |
|------------------------|-------|---|
| Cmd End | 1 | Read or write operation terminated |
| Cmd Start Acknowledge | 0 | Start of a read or write operation not acknowledged |
| | 1 | Start of a read or write operation acknowledged |
| Cmd Antenna deactivate | 0 | Activate antenna |
| | 1 | Deactivate antenna |
| Cmd Start | 0 | Reset trigger for read or write operation |
| | 1 | Set trigger for read or write operation |



The following status bits cannot be used in the "Read UID" operating mode:

- ▶ Cmd Start
- ▶ Cmd Start Acknowledge
- ▶ Cmd End

10 Operation

The device supports several operation modes selected with the command value in the process data output image:

| Operating mode | Command value | Description |
|-----------------|---------------|---|
| Read UID | 0x00 | Operating mode Read UID (→ □ 18) |
| Auto read data | 0x01 | Operating mode Auto read data (→ □ 19) |
| Auto write data | 0x02 | Operating mode Auto write data (→ □ 20) |
| Read data | 0x03 | Operating mode Read data (→ □ 21) |
| Write data | 0x04 | Operating mode Write data (→ □ 25) |

For all operating modes, the same status bits and error values in the process images apply.

10.1 Deactivate internal antenna

The internal antenna of the unit can be deactivated at any time. With antenna deactivated

- the device can still be accessed via IO-Link,
- no high-frequency magnetic field is generated by the unit,
- the unit does not recognise ID tags.

Interference between units mounted next to each other is reduced by deactivating the antenna.

Deactivate the internal antenna:

- ▶ Set the "Cmd Antenna deactivate" bit in the process data output.



The status of the internal antenna is queried via the bit "Antenna deactivated" in the process data input image.

10.2 Operating mode Read UID

In the operating mode "Read UID" the UID of an ID tag is read. Then the UID is available in the process data input. If no ID tag is in the range of the device, the 8 bytes of the UID get the value "0x00".

As soon as an ID tag is detected by the device, the UID is transferred. The transfer is continued for the min. length of the data hold time. If a new ID tag appears in the detection range during the data hold time, the UID of the new ID tag is transferred.



The default operating mode after the unit is started is "Read UID".

| Byte | Process data output | Process data input |
|------|----------------------|----------------------|
| 0 | Command value = 0x00 | Command value = 0x00 |
| 1 | Status | Status |
| 2 | ignored | UID 0 |
| 3 | ignored | UID 1 |
| 4 | ignored | UID 2 |
| 5 | ignored | UID 3 |
| 6 | ignored | UID 4 |
| 7 | ignored | UID 5 |

| Byte | Process data output | Process data input |
|------|---------------------|--------------------|
| 8 | ignored | UID 6 |
| 9 | ignored | UID 7 |
| 10 | ignored | 0x00 |
| 11 | ignored | 0x00 |
| 12 | ignored | 0x00 |
| 13 | ignored | 0x00 |
| 14 | ignored | 0x00 |
| 15 | ignored | 0x00 |
| 16 | ignored | 0x00 |
| 17 | ignored | 0x00 |
| 18 | ignored | 0x00 |
| 19 | ignored | 0x00 |
| 20 | ignored | 0x00 |
| 21 | ignored | 0x00 |
| 22 | ignored | 0x00 |
| 23 | ignored | 0x00 |
| 24 | ignored | 0x00 |
| 25 | ignored | 0x00 |
| 26 | ignored | 0x00 |
| 27 | ignored | 0x00 |
| 28 | ignored | 0x00 |
| 29 | ignored | 0x00 |
| 30 | ignored | 0x00 |
| 31 | ignored | Error value |

10.3 Operating mode Auto read data

In the operating mode "Auto read data" the bytes 0 to 28 represent the data in the memory area of the **ID tag**. The memory area is set by the parameters "Address for Auto Read/Write" and "Data Length for Auto-Read/Write".

For memory areas with a data length of < 29 bytes the data remaining in the process image is filled with the value 0x00.

The data in the process image is updated as soon as an ID tag enters the detection range. The data in the process image is valid as soon as the status bit "Cmd End" is set.

If the ID tag leaves the detection range, the data is held in the process image according to the data hold time. If the data hold time is exceeded and there is no ID tag in the detection range, the data is filled with the value 0x00.

If the ID tag remains in the detection range, the data can be read with the status bit "Cmd Start". If reading was unsuccessful, the error value is shown in the process image.



The smaller the "Length for Auto Read/Write" is set, the less time is needed for reading. That means that the dwell time of the ID tag in the detection range can be shorter.

| Byte | Process data output | Process data input |
|------|----------------------|----------------------|
| 0 | Command value = 0x01 | Command value = 0x01 |
| 1 | Status | Status |

| Byte | Process data output | Process data input |
|------|---------------------|--------------------|
| 2 | ignored | Data 0 |
| 3 | ignored | Data 1 |
| 4 | ignored | Data 2 |
| 5 | ignored | Data 3 |
| 6 | ignored | Data 4 |
| 7 | ignored | Data 5 |
| 8 | ignored | Data 6 |
| 9 | ignored | Data 7 |
| 10 | ignored | Data 8 |
| 11 | ignored | Data 9 |
| 12 | ignored | Data 10 |
| 13 | ignored | Data 11 |
| 14 | ignored | Data 12 |
| 15 | ignored | Data 13 |
| 16 | ignored | Data 14 |
| 17 | ignored | Data 15 |
| 18 | ignored | Data 16 |
| 19 | ignored | Data 17 |
| 20 | ignored | Data 18 |
| 21 | ignored | Data 19 |
| 22 | ignored | Data 20 |
| 23 | ignored | Data 21 |
| 24 | ignored | Data 22 |
| 25 | ignored | Data 23 |
| 26 | ignored | Data 24 |
| 27 | ignored | Data 25 |
| 28 | ignored | Data 26 |
| 29 | ignored | Data 27 |
| 30 | ignored | Data 28 |
| 31 | ignored | Error value |

10.4 Operating mode Auto write data

In the operating mode "Auto-write data" the data to be written is defined by the process data output image. The data is set with the parameters "Address for Auto Read/Write" and "Data Length for Auto Read/Write".

The data is written with the address and length to an **ID tag** as soon as the ID tag enters the detection range.

Max. 29 bytes become defined in the process data output image (bytes 0 to 28). For memory areas with a data length of < 29 bytes the remaining data is ignored and not written to the ID tag.

If writing was successful, the written data is copied to the process data input image and the status bit "Cmd End" is set.

If the ID tag leaves the detection range, the data is held in the process image according to the data hold time. If the data hold time is exceeded and there is no ID tag in the detection range, the data is filled with the value 0x00.

If the ID tag remains in the detection range, the data can be written with the status bit "Cmd Start". If writing was unsuccessful, the error value is shown in the process image.



The smaller the "Data Length Auto Read/Write" is set, the less time is needed for writing. That means that the dwell time of the ID tag in the detection range can be shorter.

| Byte | Process data output | Process data input |
|------|----------------------|----------------------|
| 0 | Command value = 0x02 | Command value = 0x02 |
| 1 | Status | Status |
| 2 | Data 0 | Data 0 |
| 3 | Data 1 | Data 1 |
| 4 | Data 2 | Data 2 |
| 5 | Data 3 | Data 3 |
| 6 | Data 4 | Data 4 |
| 7 | Data 5 | Data 5 |
| 8 | Data 6 | Data 6 |
| 9 | Data 7 | Data 7 |
| 10 | Data 8 | Data 8 |
| 11 | Data 9 | Data 9 |
| 12 | Data 10 | Data 10 |
| 13 | Data 11 | Data 11 |
| 14 | Data 12 | Data 12 |
| 15 | Data 13 | Data 13 |
| 16 | Data 14 | Data 14 |
| 17 | Data 15 | Data 15 |
| 18 | Data 16 | Data 16 |
| 19 | Data 17 | Data 17 |
| 20 | Data 18 | Data 18 |
| 21 | Data 19 | Data 19 |
| 22 | Data 20 | Data 20 |
| 23 | Data 21 | Data 21 |
| 24 | Data 22 | Data 22 |
| 25 | Data 23 | Data 23 |
| 26 | Data 24 | Data 24 |
| 27 | Data 25 | Data 25 |
| 28 | Data 26 | Data 26 |
| 29 | Data 27 | Data 27 |
| 30 | Data 28 | Data 28 |
| 31 | ignored | Error value |

10.5 Operating mode Read data

In the operating mode "Read data" more than 29 bytes can be read with a read operation. The data is sequentially transferred from the device to the controller.

Transfer data from the device to the controller:

- ▶ Use the control to set the following values in the process data output: the command value "0x03", the address (16 bits) and the data length (16 bits).
- ▶ With the control, start the read operation with the status bit "Cmd Start".
- ▷ The device acknowledges the start of the read operation by setting the status bit "Cmd Start Acknowledge" in the process data input.
- ▷ The device transfers the data in the process data input (data 0 to 27) and increases the block counter by 1 as soon as the first data of the ID tag is available. The block counter is reset to "0" when the value exceeds "255".
- ▶ With the control, acknowledge the receipt of the data by increasing the block counter in the process data output by "1".
- ▶ The last two steps are repeated until all data has been transferred.
- ▷ The device sets the status bit "Cmd End" with the last transfer.

The read operation is terminated.



If reading was unsuccessful, the device sets the error value and the status bit "Cmd End" in the process image. The data transmission is interrupted.

| Byte | Process data output | Process data input |
|------|----------------------|----------------------|
| 0 | Command value = 0x03 | Command value = 0x03 |
| 1 | Status | Status |
| 2 | ignored | Data 0 |
| 3 | ignored | Data 1 |
| 4 | Address (high byte) | Data 2 |
| 5 | Address (low byte) | Data 3 |
| 6 | Length (high byte) | Data 4 |
| 7 | Length (low byte) | Data 5 |
| 8 | ignored | Data 6 |
| 9 | ignored | Data 7 |
| 10 | ignored | Data 8 |
| 11 | ignored | Data 9 |
| 12 | ignored | Data 10 |
| 13 | ignored | Data 11 |
| 14 | ignored | Data 12 |
| 15 | ignored | Data 13 |
| 16 | ignored | Data 14 |
| 17 | ignored | Data 15 |
| 18 | ignored | Data 16 |
| 19 | ignored | Data 17 |
| 20 | ignored | Data 18 |
| 21 | ignored | Data 19 |
| 22 | ignored | Data 20 |
| 23 | ignored | Data 21 |
| 24 | ignored | Data 22 |
| 25 | ignored | Data 23 |
| 26 | ignored | Data 24 |
| 27 | ignored | Data 25 |

| Byte | Process data output | Process data input |
|------|---------------------|--------------------|
| 28 | ignored | Data 26 |
| 29 | ignored | Data 27 |
| 30 | Block counter | Block counter |
| 31 | ignored | Error value |

10.5.1 Example successful reading of data

The example shows that reading of the data was successful.

| | Command value | Address | Length | Data 0 to 27 | Block counter | Status bit "Cmd Start" |
|---|---------------|---------|--------|--------------|---------------|------------------------|
| Preset command | 0x00 | 0x0000 | 0x0000 | 0x00 | 0x00 | 0 |
| Controller sets command (read 35 bytes from address 0x12) | 0x03 | 0x0012 | 0x0023 | 0x00 | 0x00 | 1 |
| Device acknowledges command | 0x03 | 0x0012 | 0x0023 | 0x00 | 0x00 | 1 |
| Device sets first byte of the data | 0x03 | 0x0012 | 0x0023 | 0x00 | 0x00 | 1 |
| Controller acknowledges receipt of the data | 0x03 | 0x0012 | 0x0023 | 0x00 | 0x01 | 1 |
| Device sets more data and terminates reading | 0x03 | 0x0012 | 0x0023 | 0x00 | 0x01 | 1 |
| Controller acknowledges receipt of the data | 0x03 | 0x0012 | 0x0023 | 0x00 | 0x02 | 1 |
| Controller withdraws command value | 0x00 | 0x0000 | 0x0000 | 0x00 | 0x00 | 0 |
| Device carries out preset command | 0x00 | 0x0000 | 0x0000 | 0x00 | 0x00 | 0 |

Tab. 3: Process data output

| | Command value | Data 0 to 27 | Block counter | Error value | Status bit "Cmd End" | Status bit "Cmd Start" |
|---|---------------|--------------|---------------|-------------|----------------------|------------------------|
| Preset command | 0x00 | UID | 0x00 | 0x00 | 0 | 0 |
| Controller sets command (read 35 bytes from address 0x12) | 0x03 | UID | 0x00 | 0x00 | 0 | 0 |
| Device acknowledges command | 0x03 | 0x00 | 0x00 | 0x00 | 0 | 1 |
| Device sets first byte of the data | 0x03 | Data | 0x01 | 0x00 | 0 | 1 |

| | Command value | Data 0 to 27 | Block counter | Error value | Status bit "Cmd End" | Status bit "Cmd Start" |
|--|---------------|--------------|---------------|-------------|----------------------|------------------------|
| Controller acknowledges receipt of the data | 0x03 | Data | 0x01 | 0x00 | 0 | 1 |
| Device sets more data and terminates reading | 0x03 | Data | 0x02 | 0x00 | 1 | 1 |
| Controller acknowledges receipt of the data | 0x03 | Data | 0x02 | 0x00 | 1 | 1 |
| Controller withdraws command value | 0x03 | Data | 0x02 | 0x00 | 1 | 1 |
| Device carries out preset command | 0x00 | UID | 0x00 | 0x00 | 0 | 0 |

Tab. 4: Process data input

10.5.2 Example unsuccessful reading of data

Example shows that reading of the data was unsuccessful.

| | Command value | Address | Length | Data 0 to 27 | Block counter | Status bit "Cmd Start" |
|---|---------------|---------|--------|--------------|---------------|------------------------|
| Preset command | 0x00 | 0x0000 | 0x0000 | 0x00 | 0x00 | 0 |
| Controller sets command (read 35 bytes from address 0x12) | 0x03 | 0x0012 | 0x0023 | 0x00 | 0x00 | 1 |
| Device acknowledges command | 0x03 | 0x0012 | 0x0023 | 0x00 | 0x00 | 1 |
| Device sets first byte of the data | 0x03 | 0x0012 | 0x0023 | 0x00 | 0x00 | 1 |
| Controller acknowledges receipt of the data | 0x03 | 0x0012 | 0x0023 | 0x00 | 0x01 | 1 |
| Unit sets error value | 0x03 | 0x0012 | 0x0023 | 0x00 | 0x01 | 1 |
| (ID tag not available) | 0x00 | 0x0000 | 0x0000 | 0x00 | 0x00 | 0 |
| Controller withdraws command value | 0x00 | 0x0000 | 0x0000 | 0x00 | 0x00 | 0 |

Tab. 5: Process data output

| | Command value | Data 0 to 27 | Block counter | Error value | Status bit "Cmd End" | Status bit "Cmd Start" |
|----------------|---------------|--------------|---------------|-------------|----------------------|------------------------|
| Preset command | 0x00 | UID | 0x00 | 0x00 | 0 | 0 |

| | Command value | Data 0 to 27 | Block counter | Error value | Status bit "Cmd End" | Status bit "Cmd Start" |
|---|---------------|--------------|---------------|-------------|----------------------|------------------------|
| Controller sets command (read 35 bytes from address 0x12) | 0x03 | UID | 0x00 | 0x00 | 0 | 0 |
| Device acknowledges command | 0x03 | 0x00 | 0x00 | 0x00 | 0 | 1 |
| Device sets first byte of the data | 0x03 | Data | 0x00 | 0x00 | 0 | 1 |
| Controller acknowledges receipt of the data | 0x03 | Data | 0x01 | 0x00 | 0 | 1 |
| Unit sets error value | 0x03 | Data | 0x01 | 0x11 | 1 | 1 |
| (ID tag not available) | 0x03 | 0x00 | 0x01 | 0x11 | 1 | 1 |
| Controller withdraws command value | 0x00 | UID | 0x00 | 0x00 | 0 | 0 |

Tab. 6: Process data input

10.6 Operating mode Write data

In the operating mode "Write data" more than 29 bytes can be written with one write operation. The data is sequentially transferred from the controller to the device.

Transferring data from the controller to the device:

- ▶ Use the control to set the following values in the process data output: the command value "0x04", the address (16 bits) and the data length (16 bits).
- ▶ With the control, start the write operation with the status bit "Cmd Start".
- ▷ The device acknowledges the start of the write operation by setting the status bit "Cmd Start Acknowledge" in the process data input.
- ▶ With the control, fill the data in the process data output (data 0 to 27) and increase the block counter by "1". The block counter is reset to "0" when the value exceeds "255".
- ▷ The device acknowledges receipt of the data by increasing the block counter in the process data output by "1".
- ▶ The last two steps are repeated until all data has been transferred.
- ▷ The device sets the status bit "Cmd End" with the last transfer to the ID tag.

The write operation is terminated.



If writing was unsuccessful, the device sets the error value and the status bit "Cmd End" in the process image. The data transmission is interrupted.

| Byte | Process data output when starting the write operation | Process data output during data transfer | Process data input |
|------|---|--|--------------------|
| 0 | Command value=0x04 | Command value=0x04 | Command value=0x04 |
| 1 | Status | Status | Status |
| 2 | ignored | Data 0 | 0x00 |
| 3 | ignored | Data 1 | 0x00 |

| Byte | Process data output when starting the write operation | Process data output during data transfer | Process data input |
|------|---|--|--------------------|
| 4 | Address (high byte) | Data 2 | 0x00 |
| 5 | Address (low byte) | Data 3 | 0x00 |
| 6 | Length (high byte) | Data 4 | 0x00 |
| 7 | Length (low byte) | Data 5 | 0x00 |
| 8 | ignored | Data 6 | 0x00 |
| 9 | ignored | Data 7 | 0x00 |
| 10 | ignored | Data 8 | 0x00 |
| 11 | ignored | Data 9 | 0x00 |
| 12 | ignored | Data 10 | 0x00 |
| 13 | ignored | Data 11 | 0x00 |
| 14 | ignored | Data 12 | 0x00 |
| 15 | ignored | Data 13 | 0x00 |
| 16 | ignored | Data 14 | 0x00 |
| 17 | ignored | Data 15 | 0x00 |
| 18 | ignored | Data 16 | 0x00 |
| 19 | ignored | Data 17 | 0x00 |
| 20 | ignored | Data 18 | 0x00 |
| 21 | ignored | Data 19 | 0x00 |
| 22 | ignored | Data 20 | 0x00 |
| 23 | ignored | Data 21 | 0x00 |
| 24 | ignored | Data 22 | 0x00 |
| 25 | ignored | Data 23 | 0x00 |
| 26 | ignored | Data 24 | 0x00 |
| 27 | ignored | Data 25 | 0x00 |
| 28 | ignored | Data 26 | 0x00 |
| 29 | ignored | Data 27 | 0x00 |
| 30 | 0x00 | Block counter | Block counter |
| 31 | ignored | ignored | Error value |

10.6.1 Example successful writing of data

The example shows successful writing of data.

| | Command value | Address | Length | Data 0 to 27 | Block counter | Status bit "Cmd Start" |
|--|---------------|-----------------|--------|--------------|---------------|------------------------|
| Preset command | 0x00 | 0x0000 | 0x0000 | 0x00 | 0x00 | 0 |
| Controller sets command (write 40 bytes to address 0x10) | 0x04 | 0x0010 | 0x0028 | 0x00 | 0x00 | 1 |
| Device acknowledges command | 0x04 | 0x0010 | 0x0028 | 0x00 | 0x00 | 1 |
| Controller transfers the first data | 0x04 | Data for ID tag | | | 0x01 | 1 |

| | Command value | Address | Length | Data 0 to 27 | Block counter | Status bit "Cmd Start" |
|---|---------------|-----------------|--------|--------------|---------------|------------------------|
| Device acknowledges data | 0x04 | Data for ID tag | | | 0x01 | 1 |
| Controller transfers more data | 0x04 | Data for ID tag | | | 0x02 | 1 |
| Device acknowledges data and terminates writing | 0x04 | Data for ID tag | | | 0x02 | 1 |
| Controller withdraws command value | 0x00 | 0x0000 | 0x0000 | 0x00 | 0x00 | 0 |
| Device carries out preset command | 0x00 | 0x0000 | 0x0000 | 0x00 | 0x00 | 0 |

Tab. 7: Process data output

| | Command value | Data 0 to 27 | Block counter | Error value | Status bit "Cmd End" | Status bit "Cmd Start" |
|--|---------------|--------------|---------------|-------------|----------------------|------------------------|
| Preset command | 0x00 | UID | 0x00 | 0x00 | 0 | 0 |
| Controller sets command (write 40 bytes to address 0x10) | 0x04 | UID | 0x00 | 0x00 | 0 | 0 |
| Device acknowledges command | 0x04 | 0x00 | 0x00 | 0x00 | 0 | 1 |
| Controller transfers the first data | 0x04 | 0x00 | 0x00 | 0x00 | 0 | 1 |
| Device acknowledges data | 0x04 | 0x00 | 0x01 | 0x00 | 0 | 1 |
| Controller transfers more data | 0x04 | 0x00 | 0x01 | 0x00 | 0 | 1 |
| Device acknowledges data and terminates writing | 0x04 | 0x00 | 0x02 | 0x00 | 1 | 1 |
| Controller withdraws command value | 0x04 | 0x00 | 0x02 | 0x00 | 1 | 1 |
| Device carries out preset command | 0x00 | UID | 0x00 | 0x00 | 0 | 0 |

Tab. 8: Process data input

10.6.2 Example unsuccessful writing of data

Example shows that writing of the data was unsuccessful.

| | Command value | Address | Length | Data 0 to 27 | Block counter | Status bit "Cmd Start" |
|--|---------------|-----------------|--------|--------------|---------------|------------------------|
| Preset command | 0x00 | 0x0000 | 0x0000 | 0x00 | 0x00 | 0 |
| Controller sets command (write 40 bytes to address 0x10) | 0x04 | 0x0010 | 0x0028 | 0x00 | 0x00 | 1 |
| Device acknowledges command | 0x04 | 0x0010 | 0x0028 | 0x00 | 0x00 | 1 |
| Controller transfers the first data | 0x04 | Data for ID tag | | | 0x01 | 1 |
| Device acknowledges data | 0x04 | Data for ID tag | | | 0x01 | 1 |
| Controller transfers more data | 0x04 | Data for ID tag | | | 0x02 | 1 |
| Device sets error value (ID tag not available) | 0x04 | Data for ID tag | | | 0x02 | 1 |
| Controller withdraws command value | 0x00 | 0x0000 | 0x0000 | 0x00 | 0x00 | 0 |
| Device carries out preset command | 0x00 | 0x0000 | 0x0000 | 0x00 | 0x00 | 0 |

Tab. 9: Process data output

| | Command value | Data 0 to 27 | Block counter | Error value | Status bit "Cmd End" | Status bit "Cmd Start" |
|--|---------------|--------------|---------------|-------------|----------------------|------------------------|
| Preset command | 0x00 | UID | 0x00 | 0x00 | 0 | 0 |
| Controller sets command (write 40 bytes to address 0x10) | 0x04 | UID | 0x00 | 0x00 | 0 | 0 |
| Device acknowledges command | 0x04 | 0x00 | 0x00 | 0x00 | 0 | 1 |
| Controller transfers the first data | 0x04 | 0x00 | 0x00 | 0x00 | 0 | 1 |
| Device acknowledges data | 0x04 | 0x00 | 0x01 | 0x00 | 0 | 1 |
| Controller transfers more data | 0x04 | 0x00 | 0x01 | 0x00 | 0 | 1 |
| Device acknowledges data and terminates writing | 0x04 | 0x00 | 0x01 | 0x11 | 1 | 1 |
| Controller withdraws command value | 0x04 | 0x00 | 0x01 | 0x11 | 1 | 1 |

| | Command value | Data 0 to 27 | Block counter | Error value | Status bit "Cmd End" | Status bit "Cmd Start" |
|-----------------------------------|---------------|--------------|---------------|-------------|----------------------|------------------------|
| Device carries out preset command | 0x00 | UID | 0x00 | 0x00 | 0 | 0 |

Tab. 10: Process data input

10.7 Error values in the process data input

| Value | Name | Description |
|-------|---------------------------|---|
| 0x00 | RFID_NOERROR | No error, read or write operation successful. |
| 0x01 | RFID_UNKNOWN_COMMAND | Unknown command value |
| 0x11 | COMMAND_NO_RESPONSE | <ul style="list-style-type: none"> ID tag does not respond. ID tag outside the range. ID tag does not support the operation or wrong parameter (e.g. the data block is too big). |
| 0x12 | COMMAND_RX_ERROR | Error during reception of the data of the ID tag. |
| 0x21 | TAG_COMMAND_NOT_SPECIFIED | Command is not supported by the ID tag. |
| 0x22 | TAG_COMMAND_SYNTAX | Parameter of the command wrong. |
| 0x23 | TAG_OPTION_NOT_SUPPORTED | ID tag does not support option of the command. |
| 0x2F | TAG_OTHER | ID tag indicates other error during execution of the command. |
| 0x30 | TAG_BLOCK_NOT_USABLE | The data block of the ID tag cannot be used (e.g. the data block does not exist). |
| 0x31 | TAG_BLOCK_ALREADY_BLOCKED | The data block was already locked. |
| 0x32 | TAG_BLOCK_NOT_UPDATEABLE | The data block is locked and cannot be overwritten. |
| 0x33 | TAG_BLOCK_WRITE_VERIFY | The data block was not correctly written (e.g. the memory area is defective). |
| 0x34 | TAG_BLOCK_LOCK_VERIFY | The data block cannot be locked (e.g. the memory area is defective). |

11 Maintenance, repair and disposal

The unit is maintenance-free.

- ▶ Contact ifm in case of malfunction.
- ▶ Do not open the housing as the unit does not contain any components which can be maintained by the user. The unit must only be repaired by the manufacturer.
- ▶ Clean the device using a dry cloth.
- ▶ Dispose of the unit in accordance with the national environmental regulations.

12 Approvals/standards

For approvals and standards, the following information is available:

- Test standards and regulations: documentation.ifm.com
- EU declaration of conformity and approvals: documentation.ifm.com
- Notes relevant for approval: Package insert of the device and documentation.ifm.com

Glossary

ID tag

An ID tag is used to identify objects. A read/write device is used to read the ID tag via a high-frequency radio signal. An ID tag consists of an antenna, an analogue circuit for receiving and transmitting (transceiver), a digital circuit and a non-volatile memory.

IODD

Digital description of the device. The IODD is required for device parameter setting via IO-Link.

IO-Link

IO-Link is a standardised IO technology (IEC 61131-9) for communicating with sensors and actuators. Point-to-point communication is based on 3-wire sensor and actuator connection. IO-Link is not a fieldbus, but the further development of the previous connection technology.

UID

Unique Identification Number; unique identification number of a device.