

ifm electronic



Operating instructions
PMD 3D sensor

efector250[®]

O3D2xx

UK

80228931 / 01 08 / 2015

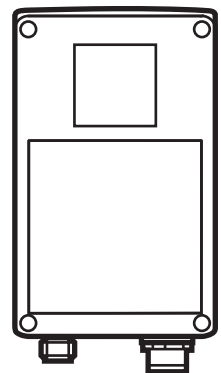

Contents

1	Preliminary note	4
1.1	Warning signs used	4
2	Safety instructions	4
3	Items supplied	5
3.1	Accessories	5
3.2	Software	5
4	Functions and features	5
5	Basics	6
5.1	General	6
5.2	Measuring principle	6
5.2.1	Unambiguous range	7
5.2.2	Extraneous light	7
5.2.3	Range	7
5.2.4	Mixed edges	8
5.2.5	Movement artefacts	8
5.2.6	Reflective surfaces	9
5.2.7	Measured values with saturation / underexposed pixels	9
6	Function	9
6.1	Range of functions	9
6.1.1	Sensor program distance	10
6.1.2	Sensor program volume	10
6.1.3	Sensor program level	10
6.2	Window function	10
6.3	Hysteresis	10
6.4	Scaling of the measuring range	10
7	Installation	10
7.1	Mounting accessory	10
7.2	Mounting dimensions	11
7.3	Installation location / Installation conditions	11
7.3.1	Interference caused by adjacent units	12
8	Electrical connection	12
8.1	Wiring	13
8.2	External trigger source	13
9	Operating and display elements	13
9.1	View of the unit	13
9.2	LEDs	14
9.3	Display	14
9.4	Buttons	15
10	Set-up	15
10.1	Settings without PC operating software	16

10.2	Parameter setting	16
10.3	Parameter description	17
10.4	Menu structure	18
10.5	External selection of the application.	18
10.6	Lock/unlock operating keys	19
10.7	Parameter setting via PC operating software.	19
11	Operation	19
12	Scale drawing	20
13	Maintenance, repair and disposal.	20
14	Approvals/standards	20
15	Note on the software.	21

UK

Licences and trademarks



Microsoft®, Windows®, Windows XP® and Windows Vista® are registered trademarks of Microsoft Corporation.

Adobe® and Acrobat® are registered trademarks of Adobe Systems Inc.

All trademarks and company names are subject to the copyright of the respective companies.

1 Preliminary note

Symbols used

- ▶ Instruction
- > Reaction, result
- [...] Designation of pushbuttons, buttons or indications
- Cross-reference
-  Important note:
Non-compliance can result in malfunctions or interference
-  Information
Supplementary note

1.1 Warning signs used

WARNING

Warning of serious personal injury.
Death or serious irreversible injuries may result.

2 Safety instructions

This manual is part of the device.

It contains information and illustrations about the correct handling of the device and must be read before installation or use.

Observe the operating instructions.

Non-observance of the instructions, operation which is not in accordance with use as prescribed below, wrong installation or handling can affect the safety of people and machinery.

The installation and connection must comply with the applicable national and international standards.

Responsibility lies with the person installing the unit.

Only the signals indicated in the technical data or on the device label may be supplied to the connections or wires.

3 Items supplied

PMD 3D sensors O3D200, O3D201, O3D222, O3D223
Operating instructions ident no.: 80228931

The device is supplied without installation/connection accessories and software.

3.1 Accessories

www.ifm.com

→ Data sheet direct → e.g. O3D200 → Accessories.

3.2 Software

The software is available at:

www.ifm.com

→ Data sheet direct → E3D200 → Download/Software.

UK

4 Functions and features

The PMD 3D sensor is an optical camera; the pixels measure the distance between the camera and the closest surface. The unit illuminates the scene using its own internal light source and processes the light reflected from the surface. Then one or several process values can be generated via the image processing.

These values are transferred to the digital/analogue outputs, the states are made available at the outputs so that the level, distance and volume applications can be evaluated.

5 Basics

5.1 General

The distance measurement is based on the time-of-flight principle. Each pixel measures the distance to the closest surface in the direction of view. On the basis of the measurement a distance image is created; the unit detects the distances in the unambiguous range.

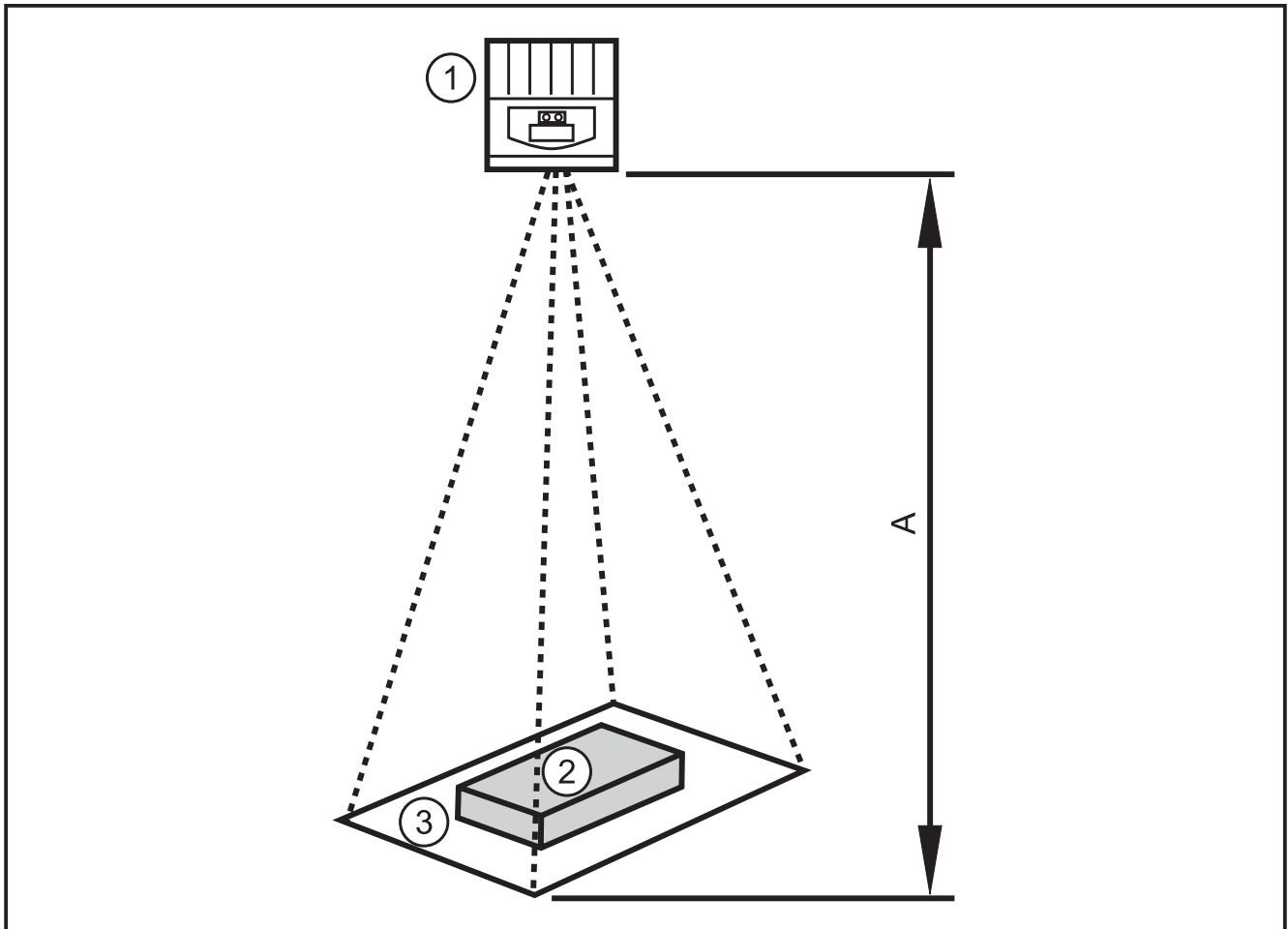

- 1: Sensor
- 2: Object
- 3: Field of view
- A: Distance / measuring range

5.2 Measuring principle

The unit measures using the time-of-flight principle on the basis of a phase measurement with modulated light. Due to this principle the following has to be considered for the measurements.

5.2.1 Unambiguous range

The unit detects distances in an unambiguous range (E) to be defined. Each object beyond this range could be measured as if part of the original range.

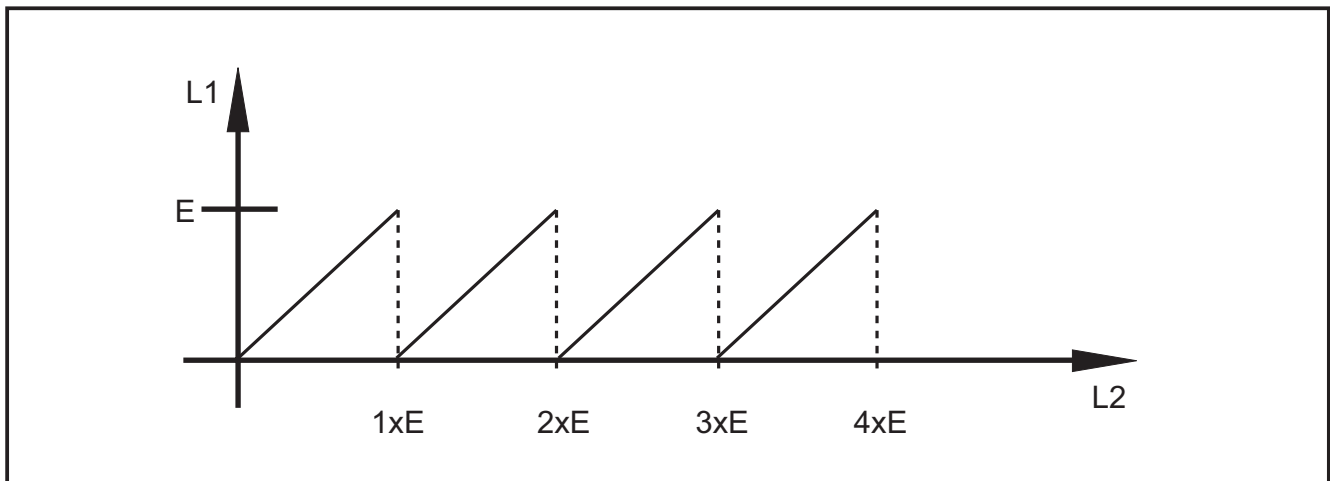

E : Unambiguous range

$L1$: Distance to the object measured by the unit

$L2$: Real distance to the object

5.2.2 Extraneous light

Since modulated light is used for the measurement, brighter ambient light can increase the noise of the measured values. The accuracy of the distance measurement increases with higher light intensity of the modulated light. Measured values of dark objects are noisier than those of brighter objects with the other conditions remaining identical.



Avoid any strong ambient light, sunlight on the sensor and the object.

5.2.3 Range

The range of the measurement depends on the distance, the exposure time and the reflectivity of the object to be detected. Since the unit illuminates the scene, the light intensity decreases quadratically with the distance. The combination of the effects distance, exposure time and reflectivity influences the received light intensity:

- black objects with a diffuse reflectivity of 5% are detected at distances of approx. 2 m.
- retroreflective objects travel through the unambiguous range several times and falsify the result → Chapter 5.2.1.
- bright objects generate less distance noise than dark objects.
- objects close to the unit generate less distance noise than objects farther away from the unit.

Reproducibility depends on the reflectivity and the distance of the object.

5.2.4 Mixed edges

The visible surface of a pixel is approx. 12 x 12 mm at a distance of 1 m and 25 x 25 at a distance of 2 m. If the distance across the pixel area is not constant, an average distance is measured. In order to detect an object at the right distance, it requires a pixel surface of min. twice its size.

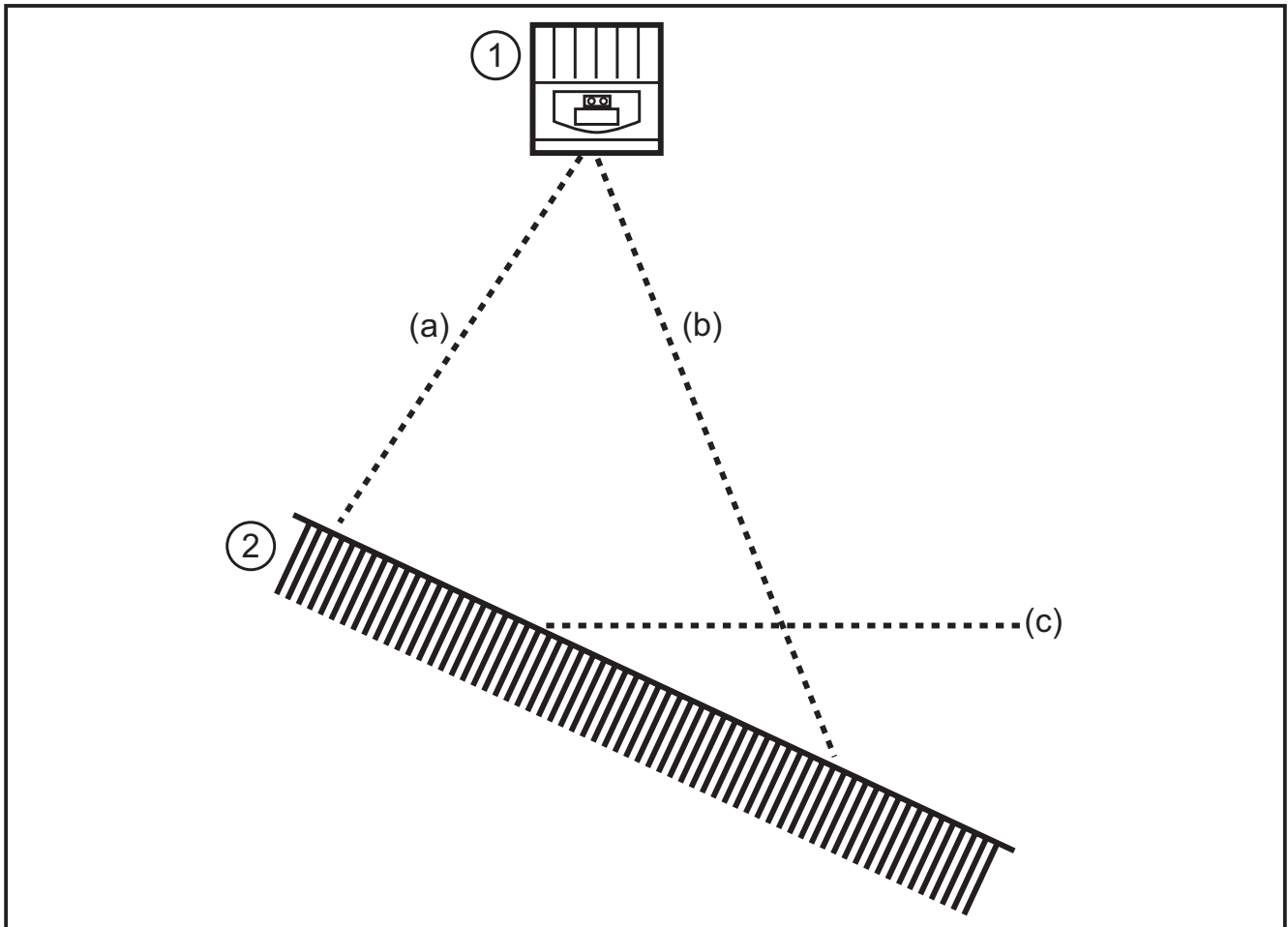

- 1: Sensor
- 2: Object
- a: Measured distance a
- b: Measured distance b
- c: Averaged distance c

5.2.5 Movement artefacts

In order to measure the distance four exposures are required internally. They are taken rapidly one after the other. If the object moves by more than half a pixel during this time, measurement errors will occur.

- Avoid movements of the object during exposure.

5.2.6 Reflective surfaces

If the unit illuminates an object directly (a) and indirectly (b) via an adjacent reflective surface, a measurement error will occur. In that case the unit detects the object at a larger distance since the indirect beam path (b) is longer.

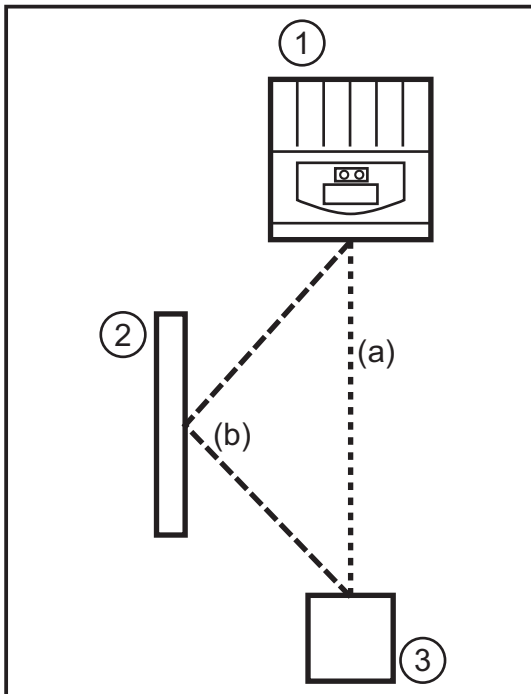

- 1: Sensor
- 2: Reflective surface
- 3: Object

- ▶ Avoid reflective surfaces in the visible area of the unit.

5.2.7 Measured values with saturation / underexposed pixels

Each pixel is assigned a measured value. If the received signal is too strong (saturation), the pixel is assigned the distance 0 m. If the received signal is too weak (underexposure), the pixel is assigned the distance 6.5 m.

- ▶ Changing exposure setting
 - ▶ Increasing dynamics
- Programming manual E3D200 → Menu image quality

6 Function



Detailed documentation of the settings and parameter setting of the unit described in this chapter → programming manual.

6.1 Range of functions

The unit enables the evaluation of volume, level or distance.

6.1.1 Sensor program distance

This program provides the distance from an object to the sensor as a result (unit of measurement mm or inches).

6.1.2 Sensor program volume

This program determines the respective volume (unit of measurement litre) on the basis of the surface structure and the distance from the object to the background).

6.1.3 Sensor program level

This program calculates a certain level on the basis of the distance value averaged across the total object surface and the distance of the object to the background (unit of measurement mm or inches).

6.2 Window function

The window function enables the monitoring of a defined acceptable range. If the process value is between the set point and the reset point, the output is closed (window function, normally open) or open (window function, normally closed). The window functions also work with switching hysteresis.

6.3 Hysteresis

The hysteresis keeps the switching state of the output stable if the process value fluctuates around the set point. When an object approaches, the output switches when the set point is reached. When the object is removed again, the output does not switch back before the reset point is exceeded. Set and reset points are symmetrically arranged around the selected switch point. The hysteresis is the distance between the set and reset points.

6.4 Scaling of the measuring range

These two functions provide an analogue signal on the output which increases linearly depending on the size of the process value.

With the parameter analogue start point you define the process value at which the analogue signal is 4 mA / 0 V.

With the parameter analogue end point you define the process value at which the analogue signal is 20 mA / 10 V.

7 Installation

7.1 Mounting accessory

Depending on the intended location and type of mounting the following mounting accessories are for example available:

Description	Art. no.
Mounting set for shaft \varnothing 14 mm (clamp and bracket for types O2Dxxx, O2Mxxx, O2Ixxx)	E3D103
Shaft, straight \varnothing 14 mm, length 130 mm, M12	E20939
Shaft, angled \varnothing 14 mm, length 200 mm, M12	E20941

You can find more information about the available accessories at:

www.ifm.com

→ Data sheet direct → e.g. O3D200 → Accessories

7.2 Mounting dimensions

The device is mounted using 2 M4 screws and nuts.
Hole dimensions → Chapter 12 Scale drawing.

7.3 Installation location / Installation conditions

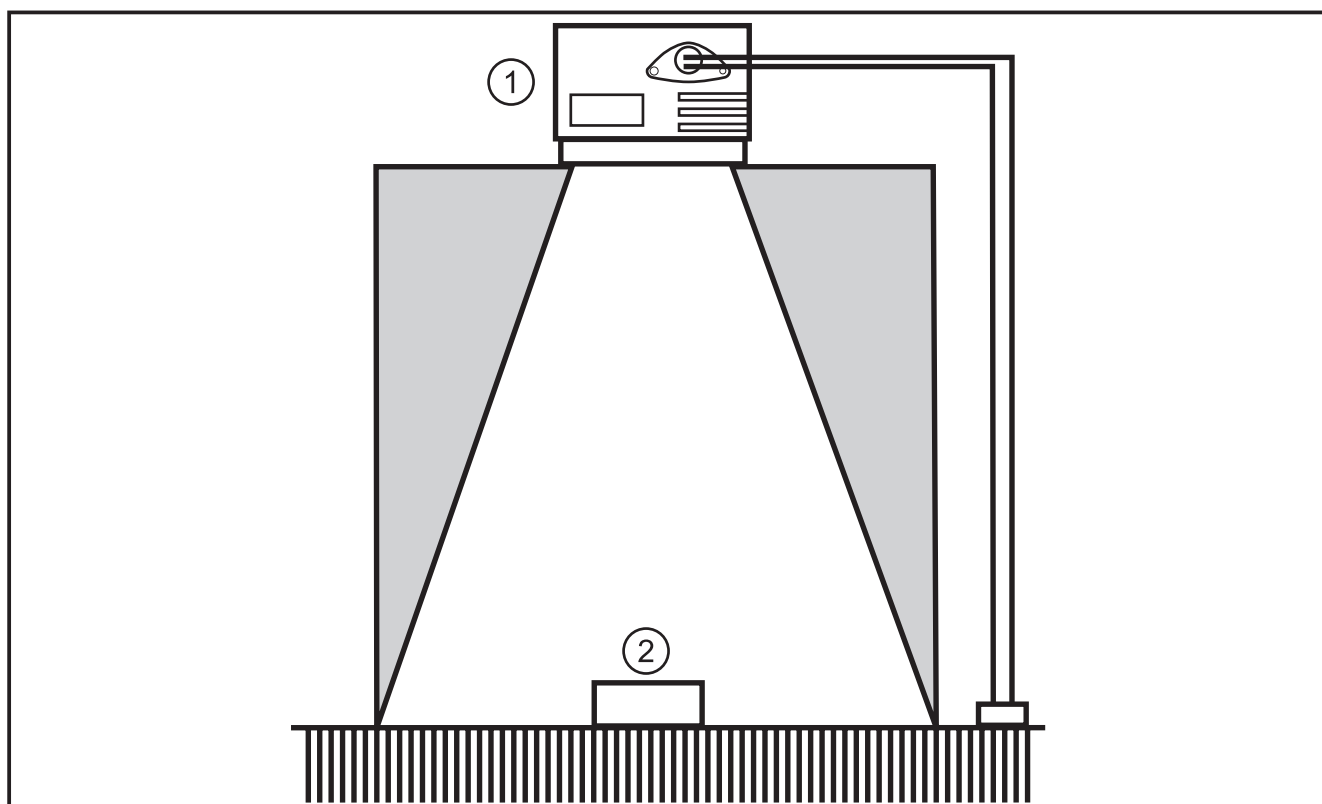

- 1: Sensor
2: Object



Installation instructions

Neither objects nor the mounting bracket nor other objects may be in the area shown in grey.

- ▶ Place the objects completely within the visible range of the unit.
- ▶ Avoid objects at short range of the light cone (50°).
- ▶ Avoid back light or scattered light situations.
- ▶ Keep a distance of min. 10 cm between the unit and the object.

UK

- ▶ Avoid installation in heavily polluting areas of the machine.
- ▶ Do not install behind glass.
- > Measurement inaccuracies.
- ▶ The connected cables must be provided with a strain relief.

7.3.1 Interference caused by adjacent units

If several units are installed next to each other, simultaneous exposure may cause interference.

- ▶ Operate the units alternately.
- ▶ Connect the ready output of unit 1 to the trigger input of unit 2, connect the ready output of unit 2 to the trigger input of unit 3 etc.
- > Avoidance of scattered light (light overlapping) caused by an adjacent unit.



The O3D illumination (infrared) can influence and disturb other units based on infrared light (through-beam sensors, pushbuttons, remote controls, etc.).

8 Electrical connection

NOTE



The unit must be connected by a qualified electrician.

Device of protection class III (PC III)

The electric supply must only be made via PELV circuits.

- ▶ Disconnect power before connecting the unit.

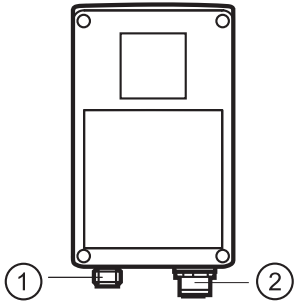
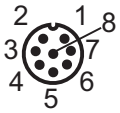
8.1 Wiring

	Process interface (1)	
	M12 connector, A-coded, 8 poles	
		<ul style="list-style-type: none"> 1 U+ (24 V) 2 Trigger input 3 0 V 4 Switching output 1 (digital or analogue) 5 Ready 6 Switching output 2 (digital) 7 Switching input 1 8 Switching input 2
	Parameter setting interface (2)	
M12 socket, D-coded, 4 poles		
	<ul style="list-style-type: none"> 1 Ethernet TD + 2 Ethernet RD + 3 Ethernet TD- 4 Ethernet RD- S Shield 	

UK

For information about available sockets/connectors see:

www.ifm.com

→ Data sheet direct → O3D200 → Accessories

8.2 External trigger source

- ▶ Connect an external trigger source (e.g. a diffuse reflection sensor) to the trigger input of the device.

9 Operating and display elements

9.1 View of the unit

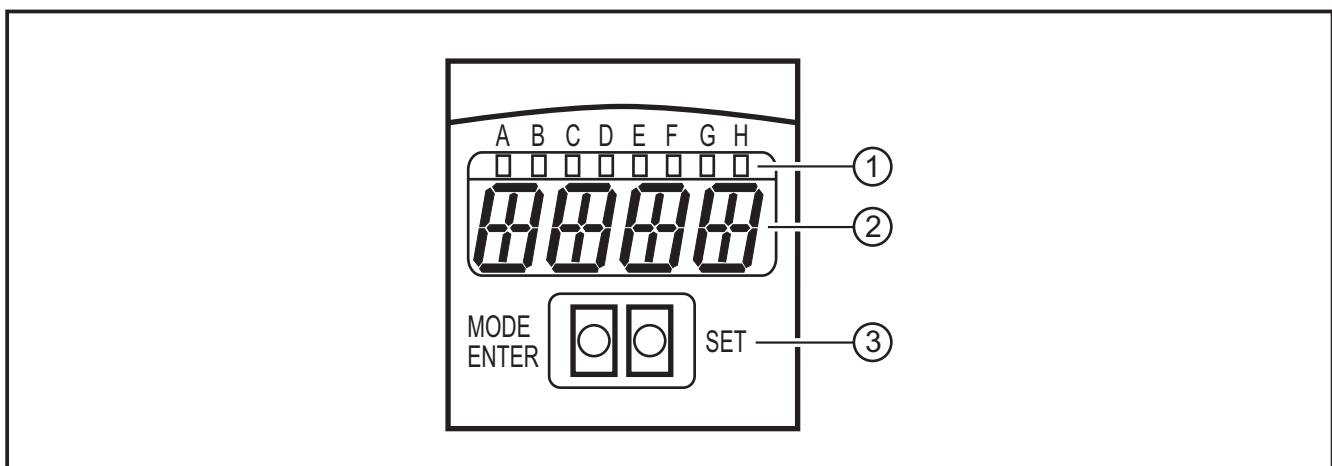

- 1: LEDs (Function display)
- 2: Display (Result display/ dialogue/ parameters)
- 3: Buttons (Parameter setting)

9.2 LEDs

LED	Name	Colour	Status	Description
A	Power	green	on	Supply voltage applied Device ready for operation
			flashing (6 Hz)	Device fault
B	Eth	green	on	Ethernet connection exists
			flashing	Ethernet signal (data transmission)
C	Con	green	on	Connected with PC operating program
D	RDY	green	on	Sensor ready for trigger
E	I1	yellow	on	Switching input 1 switched
F	I2	yellow	on	Switching input 2 switched
G	O1	yellow	on	Switching output 1 switched
			flashing (6 Hz)	Short circuit switching output 1
H	O2	yellow	on	Switching output 2 switched
			flashing (6 Hz)	Short circuit switching output 2

9.3 Display

In the operating mode the process value is continuously displayed on output 1 (mm, inches or litres).

Display	Description
OnLI	Connection via operating program, application administration
Parm	Connection via operating program, processing an application
Init	Device initialisation immediately after power on
nEAR	Object too close to the sensor
LOAd	Loading a new application
donE	Loading a new application terminated (indication 1 s)
Lock	Operating keys locked
uLoc	Operating keys unlocked
rEdY	Device ready for trigger
DHCP noIP	No DHCP server found. Both character strings are displayed alternately.
WAIT	No active/valid configuration available Unit is busy Displyed immediately after power on
4001	Firmware version number is briefly displayed after power on
v020	Version number of the IO controller software is briefly displayed after power on

Error messages	
Display	Description / Remedy
SC	Short circuit of a switching output
NoAp	No configuration assigned to the selected memory location
E001	General error
E002	No communication with the image sensor
E004	Temperature of the device too high or too low
E005	Hardware error
E006	Internal database error
E007	Internal database error
E008	Internal database error
E009	Communication error
E010	Memory error
E011	Memory used
E012	Internal application error
E015	Data consistency error: The current configuration is inconsistent. This error can be acknowledged via the menu. The previous parameter values are restored.
E016	Internal data error: Error when reading the calibration values. The device has to be returned to ifm.



Error messages of type E0xx (e.g. E002 - no communication with the image sensor) indicate an internal fault.

► Contact the ifm → www.ifm.com

9.4 Buttons

Button	Function
MODE/ENTER	Changing to the parameter setting mode
SET	Selecting the subparameters Setting/changing/selecting the parameter values - incremental by pressing briefly (selection) - continuously by keeping the button pressed (5 s)

10 Set-up

Set-up is carried out via a menu-guided PC operating software.

The device stores up to 32 applications (= parameter sets).

An application consists of

- the image capture parameters
- the program parameters
- the input or output application (I/O) of the process value

10.1 Settings without PC operating software

- Display mode
- Trigger mode
- Network (IP address, gateway, subnet mask, DHCP mode)
- Set the input parameters
- Reset the device to factory setting

The device parameters are set using the 2 buttons [MODE/ENTER] and [SET].

Basic principle:

1. Activate a parameter with [Mode/Enter].
2. Set/select the parameter value with [SET].
3. Confirm the value with [MODE/ENTER].

10.2 Parameter setting

1. Change to the parameter mode and activate parameters:

- ▶ Press [MODE/ENTER] for more than 1 s.
- ▶ Activate subparameters (e.g. EF → DS) with [SET] .

2. Set/select the parameter value:

- ▶ Press [SET].
- > The current value or the current setting of the parameter is displayed.
- ▶ Press [SET] again and keep it pressed.
- > Display starts flashing (approx. 5 s)
- > Display stops flashing.
- ▶ Release [SET].
- ▶ Set/select the value with [SET] by pressing the button once or continuously by keeping the button pressed.
Preset selection values are continuously passed through when the button is kept pressed (e.g.: off, on, off, on, etc.).



- > When three-digit numerical values are entered (e.g. IP address), the menu changes automatically to the next value to be set.

3. Confirm parameter value

- ▶ Confirm the displayed setting/selection with [MODE/ENTER].
- > Display changes to the output parameter.

If no button is pressed for 15 s, the device returns automatically to the respective output parameter (e.g. IP → nET → EF → evaluation mode). Settings that were not confirmed with [MODE/ENTER] are rejected.



- ▶ Network parameters are accepted only after a restart.
- ▶ Disconnect the sensor and connect it again.
- > Network parameters have been accepted.

10.3 Parameter description

Parameter			Description	Adjustable values Factory setting (<u>x</u>)
EF			Extended functions	
	diS	d1 - d3 rd1- rd3	Display mode Rotate display by 180° Abbreviations: Display not rotated Display rotated by 180° 1 - 3 repetition rate of the display 1 = 50 ms / 2 = 200 ms / 3 = 600 ms	<u>norm</u> , USd, off
	TriG	ConT PoS nEG	Select trigger mode Sensor works without trigger Trigger positive edge Trigger negative edge	
	nET		Network Parameters for network operation (IP, GWA, SNM, DHCP) These parameters are intended for setup using the PC operating software or for use in another network.	
		IP	Enter or change IP address	
		GWA	Enter or change gateway address	
		SNM	Enter or change subnet mask	
		DHCP	Dynamic Host Configuration Protocol Ensures dynamic assignment of an IP address using a DHCP server. If set to "on", the device setting must be opera- ted in a network with DHCP server. Otherwise it cannot be accessed via the PC operating software E3D200. If set to "off", the fixed network settings (→IP, nETm, GWP) are used.	<u>off</u> , on
	InP		Activate / deactivate the external selection of the applicaton via pins 7 and 8	
	FW		Display of the current firmware version	
	rES		Reset Reset the device to factory setting	

10.4 Menu structure

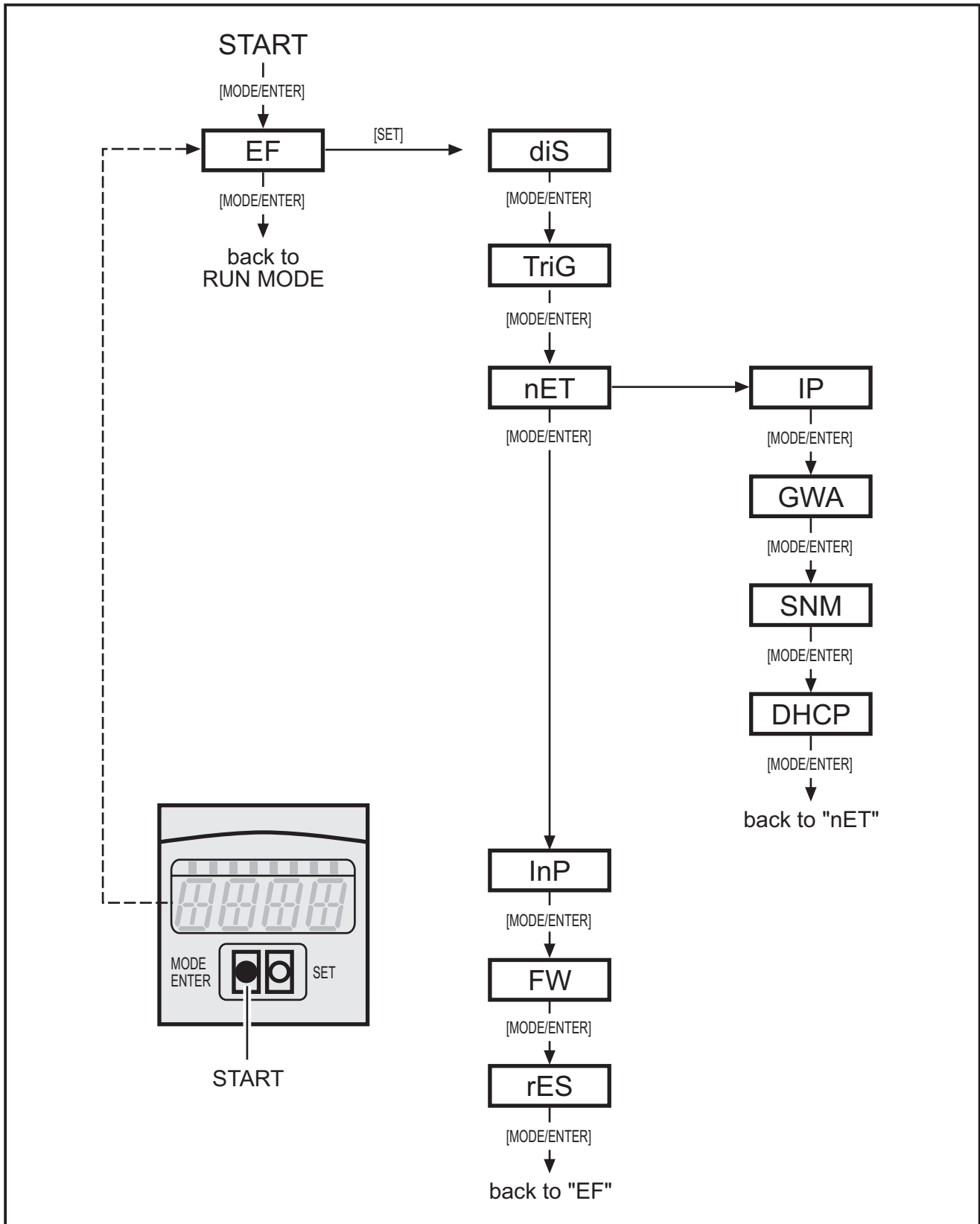

UK

10.5 External selection of the application

If this option is activated, pins 7 and 8 of the process interface are used as inputs which can externally switch the first four applications.

Pin 7 is the least significant bit (LSB), pin 8 the most significant bit (MSB); the following switchings are possible:

- Pin 7: 0, pin 8: 0 -> application on memory location 1 active,
- Pin 7: 1, pin 8: 0 -> application on memory location 2 active,
- Pin 7: 0, pin 8: 1 -> application on memory location 3 active,
- Pin 7: 1, pin 8: 1 -> application on memory location 4 active

10.6 Lock/unlock operating keys

- ▶ Press [MODE/ENTER] and [SET] simultaneously for longer than 10 s.



When the sensor is connected with the PC operating software, the [MODE/ENTER] und [SET] buttons are locked. Operation via software is of priority.

10.7 Parameter setting via PC operating software

The PC operating software is described in a separate document → Programming manual E3D200.

www.ifm.com

→ Data sheet direct → E3D200 → Additional data

11 Operation

When the supply voltage has been applied, the unit is automatically in the evaluation mode after approx. 30 s. The unit performs the stored and configured function and generates output signals according to the set parameters.

The display indicates the current evaluation result, the yellow LEDs signal the switching status of the outputs or inputs.

12 Scale drawing

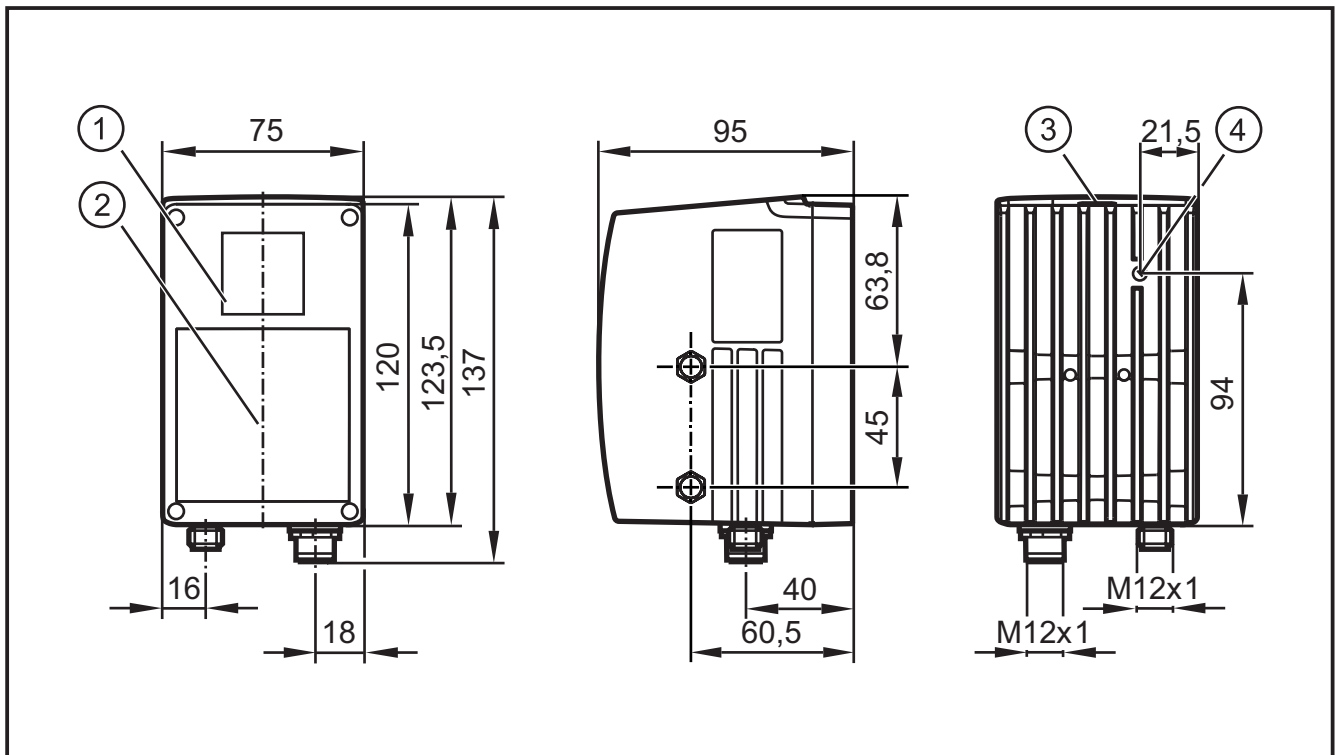

- 1: Lens
- 2: Illumination unit
- 3: Display / push-buttons / LEDs
- 4: Focal setter

13 Maintenance, repair and disposal

- ▶ Keep the lens window free from soiling.
To clean the lens window, do not use any detergents or solvents which might damage it.
- ▶ Do not open the housing, as the device does not contain any components which must be maintained by the user. The device must only be repaired by the manufacturer.
- ▶ Dispose of the device in accordance with the national environmental regulations.

14 Approvals/standards

The CE Declaration of Conformity is available at:

www.ifm.com

→ Data sheet direct → e.g. O3D200 → Approvals

UK

15 Note on the software

This unit contains (maybe modified) Open Source software, which is subject to special licensing terms.

For copyright information and licensing terms please refer to:
www.ifm.com/int/GNU

For software subject to the GNU General Public License or the GNU Lesser General Public License the source code can be requested against payment of the copying and shipping costs.

UK