

BNI IOL-302-S02-R026 **IO-Link 1.1 sensor/actuator hub** **with extension port** **User's Guide**



Contents

| | | |
|----------|---|-----------|
| 1 | User Instructions | 4 |
| 1.1. | Structure of the Manual | 4 |
| 1.2. | Typographical Conventions | 4 |
| | Enumerations | 4 |
| | Actions | 4 |
| | Syntax | 4 |
| | Cross-references | 4 |
| 1.3. | Symbols | 4 |
| 1.4. | Abbreviations | 4 |
| 1.5. | Deviating views | 4 |
| 2 | Safety | 5 |
| 2.1. | Intended use | 5 |
| 2.2. | Installation and Startup | 5 |
| 2.3. | General Safety Notes | 5 |
| 2.4. | Resistance to Aggressive Substances | 5 |
| | Dangerous voltage | 5 |
| 3 | First Steps | 6 |
| 3.1. | Connection Overview | 6 |
| 3.2. | Mechanical Connection | 7 |
| 3.3. | Electrical Connection | 7 |
| | Functional ground | 7 |
| | IO-Link connection | 7 |
| | Power supply | 7 |
| | Connecting the sensor hub | 8 |
| | Module variants | 8 |
| | Sensor/actuator interface | 8 |
| | Extension port | 8 |
| | Extension port configuration | 9 |
| 4 | Configuration: "Extension Off" | 10 |
| 4.1. | IO-Link Data | 10 |
| 4.2. | Process Data/Input Data | 10 |
| 4.3. | Process Data/ Output Data | 11 |
| 4.4. | Parameter Data/Demand Data | 12 |
| | Parameter Data/Demand Data | 12 |
| | Inversion of the inputs 40hex | 13 |
| | Safe state of Outputs 42hex | 13 |
| | Safe state of the outputs on Pin 4, 42hex | 13 |
| | Safe state of the outputs on Pin 2, 43hex | 14 |
| | Voltage monitoring 44hex | 15 |
| | Monitoring the outputs 45hex | 15 |
| 5 | Configuration: extended with BNI IOL-302-S02-R026 | 16 |
| 5.1. | IO-Link Data | 16 |
| 5.2. | Process Data/Input Data | 16 |
| 5.3. | Process Data/ Output Data | 18 |
| 5.4. | Parameter Data/Demand Data | 19 |
| | Parameter Data/Demand Data | 19 |
| | Inversion of the inputs 40hex | 20 |
| | Safe state of Outputs 42hex | 21 |
| | Safe state of the outputs on Pin 4, 42hex | 21 |
| | Safe state of the outputs on Pin 2, 43hex | 22 |
| | Voltage monitoring 44hex | 23 |
| | Monitoring the outputs 45hex | 23 |
| | Setting the serial number 54hex | 24 |
| 6 | Configuration Extended with Valve Terminal Connector with 22/24 Valves | 25 |
| 6.1. | IO-Link Data | 25 |

| | | |
|--------------|---|-----------|
| 6.2. | Process Data/Input Data | 25 |
| 6.3. | Process Data/ Output Data | 26 |
| 6.4. | Parameter Data/Demand Data | 28 |
| | Parameter Data/Demand Data | 28 |
| | Inversion of the inputs 40hex | 29 |
| | Safe state of Outputs 42hex | 30 |
| | Safe state of the Outputs Pin 4, 42hex | 30 |
| | Safe state of the outputs on Pin 2, 43hex | 31 |
| | Voltage monitoring 44hex | 32 |
| | Monitoring the outputs 45hex | 33 |
| | Setting the serial number 54hex | 33 |
| 6.5. | Error Codes/ Errors | 34 |
| 6.6. | Events | 34 |
| 7 | IO-Link Functions | 35 |
| 7.1. | IO-Link Version 1.0 / 1.1 | 35 |
| 7.2. | Data Storage | 35 |
| 7.3. | Block Configuration | 35 |
| 7.4. | Resetting to Factory Settings | 35 |
| 8 | Technical Data | 36 |
| 8.1. | Dimensions | 36 |
| 8.2. | Mechanical Data | 36 |
| 8.3. | Electrical Data | 36 |
| 8.4. | Operating conditions | 36 |
| 9 | Function Indicators | 37 |
| 9.1. | Function Indicators | 37 |
| | Port/Pin-LEDs | 37 |
| | LED indicator module status | 37 |
| | Digital LED indicators for inputs/outputs | 38 |
| | Extension port | 38 |
| 10 | Appendix | 39 |
| 10.1. | Type Code | 39 |
| 10.2. | Ordering Information | 39 |

1 User Instructions

- 1.1. Structure of the Manual** The manual is organized so that the sections build on one another. Chapter 2: Basic Safety Information.
.....
- 1.2. Typographical Conventions** The following typographical conventions are used in this manual.
 - Enumerations** Enumerations are shown as a list with an en-dash.
 - Entry 1.
 - Entry 2.
 - Actions** Action instructions are indicated by a preceding triangle. The result of an action is indicated by an arrow.
 - Action instruction 1.
 - ↖ Action result.
 - Action instruction 2.
 - Syntax** **Numbers:**
Decimal numbers are shown without additional indicators (e.g. 123).
Hexadecimal numbers are shown with the additional indicator `hex` (e.g. 00`hex`).
 - Cross-references** Cross-references indicate where additional information on the topic can be found.

1.3. Symbols



Attention!

This symbol indicates a safety instruction that must be followed without exception



Note

This symbol indicates general notes.

1.4. Abbreviations

| | |
|----------|-------------------------------|
| BNI | Balluff Network Interface |
| DPP | Direct Parameter Page |
| I/O port | Digital input/output port |
| EMC | Electromagnetic compatibility |
| FE | Function earth |
| IOL | IO-Link |
| LSB | Least Significant Bit |
| MSB | Most Significant Bit |
| SPDU | Service Protocol Data Unit |

1.5. Deviating views

Product views and illustrations in this guide may differ from the actual product. They are intended only as illustrative material.

2.1. Intended use

The BNI IOL-... acts as a decentralized input/output sensor module, which is connected to a higher-level IO-Link master module through an IO-Link interface.

2.2. Installation and Startup



Attention!

Installation and startup must only be carried out by trained technical personnel. Qualified personnel are people who are familiar with installation and operation of the product and have the necessary qualifications for these tasks. Any damage resulting from unauthorized tampering or improper use voids the manufacturer's guarantee and warranty. The operator must ensure that appropriate safety and accident prevention regulations are observed.

2.3. General Safety Notes

Commissioning and inspection

Before commissioning, carefully read the user's guide.

The system must not be used in applications in which the safety of persons is dependent upon proper functioning of the device.

Authorized personnel

Installation and startup must only be carried out by trained technical personnel.

Intended use

Warranty and liability claims against the manufacturer are rendered void by:

- Unauthorized tampering
- Improper use
- Use, installation or handling contrary to the instructions provided in this user's guide

Obligations of the operating company

The device is a piece of equipment in accordance with EMC Class A. This device can produce RF noise. The operator must take appropriate precautionary measures. The device may only be used with an approved power supply. Use only approved cables.

Malfunctions

In the event of defects and device malfunctions that cannot be rectified, the device must be taken out of operation and protected against unauthorized use.

Intended use is ensured only when the housing is fully installed.

2.4. Resistance to Aggressive Substances



Attention!

The BNI modules always have good chemical and oil resistance. When used in aggressive media (such as chemicals, oils, lubricants and coolants, each in a high concentration (i.e. too little water content)), the material must first be checked for resistance in the particular application. No defect claims may be asserted in the event of a failure or damage to the BNI modules caused by such aggressive media.

Dangerous voltage



Attention!

Before maintenance, disconnect the device from the power supply.



Note

In the interests of product improvement, Balluff GmbH reserves the right to change the technical data of the product and the content of this manual at any time without notice.

3 First Steps

3.1. Connection Overview

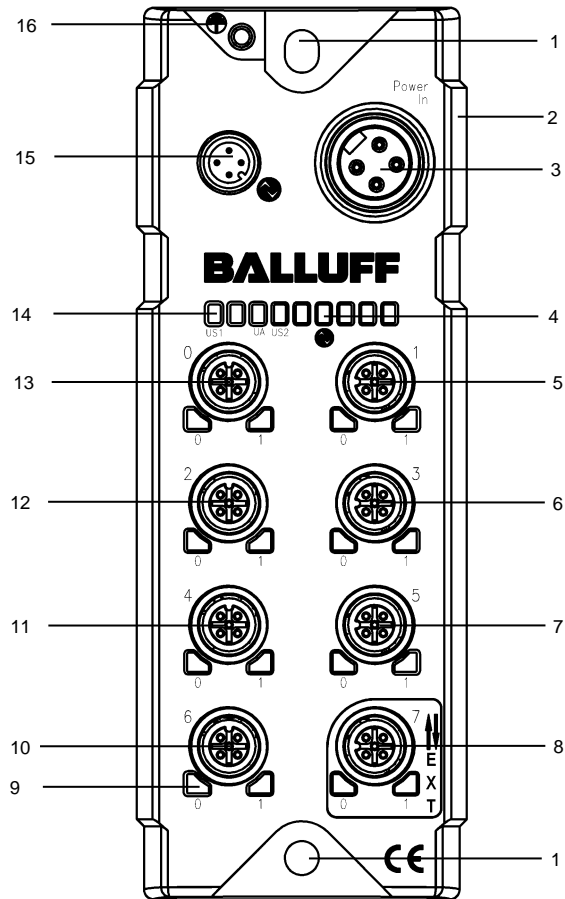

Figure 3-1: Connection overview BNI IOL-302-S02-R026

- | | |
|-------------------------------|------------------------------|
| 1 Mounting hole | 10 Port 6 |
| 2 Part label | 11 Port 4 |
| 3 Power supply | 12 Port 2 |
| 4 Status LED: communication | 13 Port 0 |
| 5 Port 1 | 14 Status LED: supply module |
| 6 Port 3 | 15 IO-Link interface |
| 7 Port 5 | 16 Ground connection |
| 8 Port 7, extension port | |
| 9 Pin/Port LED: signal status | |

3 First Steps

3.2. Mechanical Connection

The BNI IOL modules are attached using 3 M4 screws.

3.3. Electrical Connection

The BNI IOL-302-xxx-R026 modules do not require a separate supply voltage connection. Supply voltage is provided via the IO-Link interface and the higher-level IO-Link master module.

Functional ground

The modules are equipped with a ground connection.

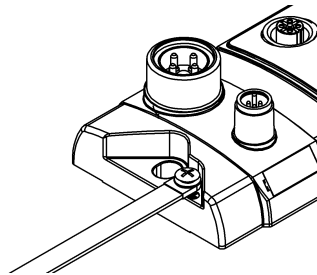

Figure 3-3: BNI ground connection IOL-302...

- Connect the sensor hub module to the ground connection.



Note

The functional ground connection from the housing to the machine must have low-impedance and be kept as short as possible.

IO-Link connection

The IO-Link connection is established via an M12 connector (A-coded, male).

IO-Link (M12, A-coded, male)

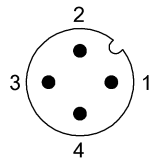

| Pin | Function |
|-----|---|
| 1 | Supply voltage for controller Us, +24 V |
| 2 | - |
| 3 | GND, reference potential |
| 4 | C/Q, IO-Link data transmission channel |

Power supply

Power IN (7/8", male)

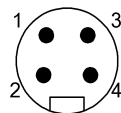

| Pin | Function |
|-----|--|
| 1 | Supply voltage for actuators, +24V |
| 2 | Supply voltage for sensors, +24V |
| 3 | GND, sensor supply reference potential |
| 4 | GND, actuator supply reference potential |

3 First Steps

Connecting the sensor hub

- Connect ground conductor to the functional ground connection, if available.
- Connect the incoming IO-Link cable to the sensor hub.



Note

A standardized sensor cable is used to connect to the higher-level IO-Link master module. Maximum length of 20 m.

Module variants

| Sensor hub variants | Digital port |
|----------------------|--|
| BNI IOL-302-S02-R026 | 16 inputs/outputs, freely configurable |

Sensor/actuator interface

Digital input/output port (M12, A-coded, female)

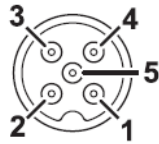

| Pin | Function |
|-----|------------------|
| 1 | +24 V |
| 2 | Input 2/output 2 |
| 3 | 0 V, GND |
| 4 | Input 1/output 1 |
| 5 | FE |



Note

For the digital inputs, the input guideline specified in EN 61131-2, Type 3 applies



Note

Unused input port sockets must be fitted with blind caps to ensure the IP67 degree of protection.

Extension port

Extension port (M12, A-coded, female)

The port acts like a sensor/actuator interface if the extension function is disabled.

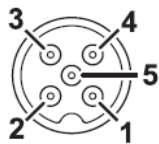

| Pin | Function |
|-----|--|
| 1 | +24 V |
| 2 | Extension port for actuator power supply |
| 3 | 0 V, GND |
| 4 | Communication |
| 5 | FE |



Note

A standardized sensor cable is used to connect to the device/sensor to be expanded. Maximum length of 20 m.

The BNI IOL-302-S02-R026 module gives you the ability to use the No. 7 slot in various ways. By default, it is used as a digital I/O slot, where both pin 2 and pin 4 can be used as a digital input or output.

This slot can be used as an extension port by making a corresponding entry in the parameter with an index of 55hex. This makes it possible to operate one of the following modules using the No. 7 slot.

- BNI IOL-302-S02-R026
- BNI IOL-751-V08-K007
- BNI IOL-751-V10-K007
- BNI IOL-751-V13-K007



Extension port configuration

| Configuration | Index 0x55 value |
|--|------------------|
| BNI IOL-302-S02-R026 | 0 |
| BNI IOL-302-S02-R026 with BNI IOL-302-S02-R026 | 1 |
| BNI IOL-302-S02-R026 with BNI IOL-751-V08-K007 | 2 |
| BNI IOL-302-S02-R026 with BNI IOL-751-V10-K007 | 3 |
| BNI IOL-302-S02-R026 with BNI IOL-751-V13-K007 | 4 |

Note
 The "Factory reset" command does not affect the configuration of the extension port in any way.

Note
 The process data length depends on the configuration.

Note
 Port Direction Parameter 41hex is not needed on BNI IOL-302-S02-R026.

The extension port can be configured using parameter 0x55 (table). If data storage or validation is used, validation (identical) must be used for configuring. Depending on the system, the Device ID has to be entered (parameter data table) or the Device ID is read out from the IODD.

4 Configuration: "Extension Off"



4.1. IO-Link Data

| BNI IOL-302-S02-R026 extension off | |
|------------------------------------|-----------------------------|
| Transmission rate | COM2 (38.4 kbaud) |
| Minimum cycle time | 6 ms |
| Process data length | 6 byte input, 2 byte output |

4.2. Process Data/Input Data

BNI IOL-302-S02-R026
Process data length of 6 bytes:

| Byte | 0 | | | | | | | | 1 | | | | | | | |
|-------------|--------------------|--------------------|--------------------|--------------------|--------------------|--------------------|--------------------|--------------------|--------------------|--------------------|--------------------|--------------------|--------------------|--------------------|--------------------|--------------------|
| Bit | 7 | 6 | 5 | 4 | 3 | 2 | 1 | 0 | 7 | 6 | 5 | 4 | 3 | 2 | 1 | 0 |
| Description | Input Port 7 Pin 4 | Input Port 6 Pin 4 | Input Port 5 Pin 4 | Input Port 4 Pin 4 | Input Port 3 Pin 4 | Input Port 2 Pin 4 | Input Port 1 Pin 4 | Input Port 0 Pin 4 | Input Port 7 Pin 2 | Input Port 6 Pin 2 | Input Port 5 Pin 2 | Input Port 4 Pin 2 | Input Port 3 Pin 2 | Input Port 2 Pin 2 | Input Port 1 Pin 2 | Input Port 0 Pin 2 |

| Byte | 2 | | | | | | | | 3 | | | | | | | |
|-------------|----------------------|----------------------|----------------------|----------------------|----------------------|----------------------|----------------------|----------------------|---|---|---|---|--------------------------|-----------------|------------------|------------------|
| Bit | 7 | 6 | 5 | 4 | 3 | 2 | 1 | 0 | 7 | 6 | 5 | 4 | 3 | 2 | 1 | 0 |
| Description | Short-circuit Port 7 | Short-circuit Port 6 | Short-circuit Port 5 | Short-circuit Port 4 | Short-circuit Port 3 | Short-circuit Port 2 | Short-circuit Port 1 | Short-circuit Port 0 | - | - | - | - | Outputs off (UA too low) | Undervoltage UA | Undervoltage US2 | Undervoltage US1 |

4 Configuration: "Extension Off"

| Byte | 4 | | | | | | | | 5 | | | | | | | |
|-------------|----------------------------|----------------------------|----------------------------|----------------------------|----------------------------|----------------------------|----------------------------|----------------------------|----------------------------|----------------------------|----------------------------|----------------------------|----------------------------|----------------------------|----------------------------|----------------------------|
| Bit | 7 | 6 | 5 | 4 | 3 | 2 | 1 | 0 | 7 | 6 | 5 | 4 | 3 | 2 | 1 | 0 |
| Description | Short-circuit Port 7 Pin 4 | Short-circuit Port 6 Pin 4 | Short-circuit Port 5 Pin 4 | Short-circuit Port 4 Pin 4 | Short-circuit Port 3 Pin 4 | Short-circuit Port 2 Pin 4 | Short-circuit Port 1 Pin 4 | Short-circuit Port 0 Pin 4 | Short-circuit Port 7 Pin 2 | Short-circuit Port 6 Pin 2 | Short-circuit Port 5 Pin 2 | Short-circuit Port 4 Pin 2 | Short-circuit Port 3 Pin 2 | Short-circuit Port 2 Pin 2 | Short-circuit Port 1 Pin 2 | Short-circuit Port 0 Pin 2 |

4.3. Process Data/ Output Data

BNI IOL-302-...

Process data length of 2 bytes

| Byte | 0 | | | | | | | | 1 | | | | | | | |
|-------------|---------------------|---------------------|---------------------|---------------------|---------------------|---------------------|---------------------|---------------------|---------------------|---------------------|---------------------|---------------------|---------------------|---------------------|---------------------|---------------------|
| Bit | 7 | 6 | 5 | 4 | 3 | 2 | 1 | 0 | 7 | 6 | 5 | 4 | 3 | 2 | 1 | 0 |
| Description | Output Port 7 Pin 4 | Output Port 6 Pin 4 | Output Port 5 Pin 4 | Output Port 4 Pin 4 | Output Port 3 Pin 4 | Output Port 2 Pin 4 | Output Port 1 Pin 4 | Output Port 0 Pin 4 | Output Port 7 Pin 2 | Output Port 6 Pin 2 | Output Port 5 Pin 2 | Output Port 4 Pin 2 | Output Port 3 Pin 2 | Output Port 2 Pin 2 | Output Port 1 Pin 2 | Output Port 0 Pin 2 |

4 Configuration: "Extension Off"

4.4. Parameter Data/Demand Data

| | DPP | SPDU | | Parameter | Data width | Access rights | Default value |
|---------------------|-------------|-------------|--------------------------|-------------------|-------------|---------------|-------------------------|
| | Index | Index | Sub-index | | | | |
| Identification data | 07hex 07 | | | Vendor ID | 2 bytes | Read only | 0378hex |
| | 08hex 08 | | | | | | |
| | 09hex 09 | | | Device ID | 3 bytes | | 0x05 0B 20 |
| | 0Ahex 10 | | | | | | |
| | 0Bhex 11 | | | | | | |
| | | 10hex 16 | 0 | Vendor name | 8 bytes | | BALLUFF |
| | | 11hex 17 | 0 | Vendor text | 16 bytes | | www.balluff.com |
| | | 12hex 18 | 0 | Product name | 20/24 bytes | | BNI IOL-302-S02-R026 |
| | | 13hex 19 | 0 | Product ID | 7 bytes | | BNI0091 |
| | | 14hex 20 | 0 | Product text | 16 bytes | | M12 sensor/actuator hub |
| | | 15hex 21 | 0 | Serial number | 16 bytes | | 0hex |
| | | 16hex 22 | 0 | Hardware revision | | | |
| | 17hex 23 | 0 | Firmware revision | | | | |
| | 18hex 24 | 0 | Application-specific tag | 32 bytes | 0hex | | |

Parameter Data/Demand Data

| | DPP | SPDU | | Parameter | Data width | Access rights | Default Value |
|----------------|-------|-------------|-----------|-------------------------|------------|---------------|---------------|
| | Index | Index | Subindex | | | | |
| Parameter data | | 40hex 64 | 0 1-16 | Inversion of the inputs | 2 bytes | Read/write | 0hex |
| | | 42hex 66 | 0 1-8 | Safe state on Pin 4 | 2 bytes | Read/write | 0hex |
| | | 43hex 67 | 0 1-8 | Safe state on Pin 2 | 2 bytes | Read/write | 0hex |
| | | 44hex 68 | 0 1-16 | Voltage monitoring | 2 bytes | Read | - |
| | | 45hex 69 | 0 1-16 | Output monitoring | 2 bytes | Read | - |
| | | 54hex 84 | 0 | Serial number | 16 bytes | Read/write | 16x00hex |
| | | 55hex 85 | 0 | Extension port | 1 byte | Read/write | 0hex |

4 Configuration: "Extension Off"

Inversion of the inputs 40_{hex}

| Byte | 0 | | | | | | | | 1 | | | | | | | |
|-------------|---------------------------|---------------------------|---------------------------|---------------------------|---------------------------|---------------------------|---------------------------|---------------------------|---------------------------|---------------------------|---------------------------|---------------------------|---------------------------|---------------------------|---------------------------|---------------------------|
| Bit | 7 | 6 | 5 | 4 | 3 | 2 | 1 | 0 | 7 | 6 | 5 | 4 | 3 | 2 | 1 | 0 |
| Sub-index | 8 | 7 | 6 | 5 | 4 | 3 | 2 | 1 | 16 | 15 | 14 | 13 | 12 | 11 | 10 | 9 |
| Description | Inversion of Port 7 Pin 4 | Inversion of Port 6 Pin 4 | Inversion of Port 5 Pin 4 | Inversion of Port 4 Pin 4 | Inversion of Port 3 Pin 4 | Inversion of Port 2 Pin 4 | Inversion of Port 1 Pin 4 | Inversion of Port 0 Pin 4 | Inversion of Port 7 Pin 2 | Inversion of Port 6 Pin 2 | Inversion of Port 5 Pin 2 | Inversion of Port 4 Pin 2 | Inversion of Port 3 Pin 2 | Inversion of Port 2 Pin 2 | Inversion of Port 1 Pin 2 | Inversion of Port 0 Pin 2 |

Inversion of port (x):

0 – Normal

1 - Inverted.

Safe state of Outputs 42_{hex}

The safe state parameter makes it possible to configure the outputs in case of a fault. If no IO-Link communication is possible or the "valid flag" of the output process data has not been set by the master, then each output adopts the configured status. The following statuses can be configured for each pin.

Safe state of the outputs on Pin 4, 42_{hex}

| Byte | 0 | | | | | | | | 1 | | | | | | | |
|-------------|-------------------------|---|-------------------------|---|-------------------------|---|-------------------------|---|-------------------------|---|-------------------------|---|-------------------------|---|-------------------------|---|
| Bit | 7 | 6 | 5 | 4 | 3 | 2 | 1 | 0 | 7 | 6 | 5 | 4 | 3 | 2 | 1 | 0 |
| Sub-index | | 4 | | 3 | | 2 | | 1 | | 8 | | 7 | | 6 | | 5 |
| Description | Safe state Port 3 Pin 4 | | Safe state Port 2 Pin 4 | | Safe state Port 1 Pin 4 | | Safe state Port 0 Pin 4 | | Safe state Port 7 Pin 4 | | Safe state Port 6 Pin 4 | | Safe state Port 5 Pin 4 | | Safe state Port 4 Pin 4 | |

4 Configuration: "Extension Off"

Safe state of the outputs on Pin 2, 43hex

| Byte | 0 | | | | | | | | 1 | | | | | | | |
|-------------|-------------------------|---|-------------------------|---|-------------------------|---|-------------------------|---|-------------------------|---|-------------------------|---|-------------------------|---|-------------------------|---|
| Bit | 7 | 6 | 5 | 4 | 3 | 2 | 1 | 0 | 7 | 6 | 5 | 4 | 3 | 2 | 1 | 0 |
| Sub-index | 4 | | 3 | | 2 | | 1 | | 8 | | 7 | | 6 | | 5 | |
| Description | Safe state Port 3 Pin 2 | | Safe state Port 2 Pin 2 | | Safe state Port 1 Pin 2 | | Safe state Port 0 Pin 2 | | Safe state Port 7 Pin 2 | | Safe state Port 6 Pin 2 | | Safe state Port 5 Pin 2 | | Safe state Port 4 Pin 2 | |

| Value | | Output state |
|-------|-----|------------------------------|
| bin | dec | |
| 00 | 0 | Output is 0V |
| 01 | 1 | Output is 24V |
| 10 | 2 | Current status is maintained |
| 11 | 3 | Not defined |

4 Configuration: "Extension Off"

Voltage monitoring
44hex

| Byte | 0 | | | | | | | | 1 | | | | | | | |
|-------------|----------------------------|----------------------------|----------------------------|----------------------------|----------------------------|----------------------------|----------------------------|----------------------------|----|----|----|----|--------------------------|-----------------|------------------|------------------|
| Bit | 7 | 6 | 5 | 4 | 3 | 2 | 1 | 0 | 7 | 6 | 5 | 4 | 3 | 2 | 1 | 0 |
| Sub-index | 8 | 7 | 6 | 5 | 4 | 3 | 2 | 1 | 16 | 15 | 14 | 13 | 12 | 11 | 10 | 9 |
| Description | Short-circuit Port 7 Pin 1 | Short-circuit Port 6 Pin 1 | Short-circuit Port 5 Pin 1 | Short-circuit Port 4 Pin 1 | Short-circuit Port 3 Pin 1 | Short-circuit Port 2 Pin 1 | Short-circuit Port 1 Pin 1 | Short-circuit Port 0 Pin 1 | - | - | - | - | Outputs off (UA too low) | Undervoltage UA | Undervoltage US2 | Undervoltage US1 |

Monitoring the outputs
45hex

| Byte | 0 | | | | | | | | 1 | | | | | | | |
|-------------|----------------------------|----------------------------|----------------------------|----------------------------|----------------------------|----------------------------|----------------------------|----------------------------|----------------------------|----------------------------|----------------------------|----------------------------|----------------------------|----------------------------|----------------------------|----------------------------|
| Bit | 7 | 6 | 5 | 4 | 3 | 2 | 1 | 0 | 7 | 6 | 5 | 4 | 3 | 2 | 1 | 0 |
| Sub-index | 8 | 7 | 6 | 5 | 4 | 3 | 2 | 1 | 16 | 15 | 14 | 13 | 12 | 11 | 10 | 9 |
| Description | Short-circuit Port 7 Pin 4 | Short-circuit Port 6 Pin 4 | Short-circuit Port 5 Pin 4 | Short-circuit Port 4 Pin 4 | Short-circuit Port 3 Pin 4 | Short-circuit Port 2 Pin 4 | Short-circuit Port 1 Pin 4 | Short-circuit Port 0 Pin 4 | Short-circuit Port 7 Pin 2 | Short-circuit Port 6 Pin 2 | Short-circuit Port 5 Pin 2 | Short-circuit Port 4 Pin 2 | Short-circuit Port 3 Pin 2 | Short-circuit Port 2 Pin 2 | Short-circuit Port 1 Pin 2 | Short-circuit Port 0 Pin 2 |

5 Configuration: extended with BNI IOL-302-S02-R026



5.1. IO-Link Data

| BNI IOL-302-002-K006 extended with BNI IOL-302-S02-R026 | |
|---|------------------------------|
| Transmission rate | COM2 (38.4 kbaud) |
| Minimum cycle time | 8.4 ms |
| Process data length | 12 byte input, 4 byte output |

5.2. Process Data/Input Data

Process data length of 12 bytes:

| Byte | 0 | | | | | | | | 1 | | | | | | | |
|-------------|---|--------------------|--------------------|--------------------|--------------------|--------------------|--------------------|--------------------|---|--------------------|--------------------|--------------------|--------------------|--------------------|--------------------|--------------------|
| Bit | 7 | 6 | 5 | 4 | 3 | 2 | 1 | 0 | 7 | 6 | 5 | 4 | 3 | 2 | 1 | 0 |
| Description | - | Input Port 6 Pin 4 | Input Port 5 Pin 4 | Input Port 4 Pin 4 | Input Port 3 Pin 4 | Input Port 2 Pin 4 | Input Port 1 Pin 4 | Input Port 0 Pin 4 | - | Input Port 6 Pin 2 | Input Port 5 Pin 2 | Input Port 4 Pin 2 | Input Port 3 Pin 2 | Input Port 2 Pin 2 | Input Port 1 Pin 2 | Input Port 0 Pin 2 |

| Byte | 2 | | | | | | | | 3 | | | | | | | |
|-------------|----------------------|----------------------|----------------------|----------------------|----------------------|----------------------|----------------------|----------------------|---|---|---|---|--------------------------|-----------------|------------------|------------------|
| Bit | 7 | 6 | 5 | 4 | 3 | 2 | 1 | 0 | 7 | 6 | 5 | 4 | 3 | 2 | 1 | 0 |
| Description | Short-circuit Port 7 | Short-circuit Port 6 | Short-circuit Port 5 | Short-circuit Port 4 | Short-circuit Port 3 | Short-circuit Port 2 | Short-circuit Port 1 | Short-circuit Port 0 | - | - | - | - | Outputs off (UA too low) | Undervoltage UA | Undervoltage US2 | Undervoltage US1 |

5 Configuration: extended with BNI IOL-302-S02-R026

| Byte | 4 | | | | | | | | 5 | | | | | | | |
|-------------|----------------------------|----------------------------|----------------------------|----------------------------|----------------------------|----------------------------|----------------------------|----------------------------|----------------------------|----------------------------|----------------------------|----------------------------|----------------------------|----------------------------|----------------------------|----------------------------|
| Bit | 7 | 6 | 5 | 4 | 3 | 2 | 1 | 0 | 7 | 6 | 5 | 4 | 3 | 2 | 1 | 0 |
| Description | Short-circuit Port 7 Pin 4 | Short-circuit Port 6 Pin 4 | Short-circuit Port 5 Pin 4 | Short-circuit Port 4 Pin 4 | Short-circuit Port 3 Pin 4 | Short-circuit Port 2 Pin 4 | Short-circuit Port 1 Pin 4 | Short-circuit Port 0 Pin 4 | Short-circuit Port 7 Pin 2 | Short-circuit Port 6 Pin 2 | Short-circuit Port 5 Pin 2 | Short-circuit Port 4 Pin 2 | Short-circuit Port 3 Pin 2 | Short-circuit Port 2 Pin 2 | Short-circuit Port 1 Pin 2 | Short-circuit Port 0 Pin 2 |

| Byte | 6 | | | | | | | | 7 | | | | | | | |
|-------------|--------------------|--------------------|--------------------|--------------------|--------------------|--------------------|--------------------|--------------------|--------------------|--------------------|--------------------|--------------------|--------------------|--------------------|--------------------|--------------------|
| Bit | 7 | 6 | 5 | 4 | 3 | 2 | 1 | 0 | 7 | 6 | 5 | 4 | 3 | 2 | 1 | 0 |
| | Extension port | | | | | | | | | | | | | | | |
| Description | Input Port 7 Pin 4 | Input Port 6 Pin 4 | Input Port 5 Pin 4 | Input Port 4 Pin 4 | Input Port 3 Pin 4 | Input Port 2 Pin 4 | Input Port 1 Pin 4 | Input Port 0 Pin 4 | Input Port 7 Pin 2 | Input Port 6 Pin 2 | Input Port 5 Pin 2 | Input Port 4 Pin 2 | Input Port 3 Pin 2 | Input Port 2 Pin 2 | Input Port 1 Pin 2 | Input Port 0 Pin 2 |

| Byte | 8 | | | | | | | | 9 | | | | | | | |
|-------------|----------------------|----------------------|----------------------|----------------------|----------------------|----------------------|----------------------|----------------------|---|---|---|---|--------------------------|-----------------|------------------|------------------|
| Bit | 7 | 6 | 5 | 4 | 3 | 2 | 1 | 0 | 7 | 6 | 5 | 4 | 3 | 2 | 1 | 0 |
| | Extension port | | | | | | | | | | | | | | | |
| Description | Short-circuit Port 7 | Short-circuit Port 6 | Short-circuit Port 5 | Short-circuit Port 4 | Short-circuit Port 3 | Short-circuit Port 2 | Short-circuit Port 1 | Short-circuit Port 0 | - | - | - | - | Outputs off (UA too low) | Undervoltage UA | Undervoltage US2 | Undervoltage US1 |

| Byte | 10 | | | | | | | | 11 | | | | | | | |
|-------------|----------------------------|----------------------------|----------------------------|----------------------------|----------------------------|----------------------------|----------------------------|----------------------------|----------------------------|----------------------------|----------------------------|----------------------------|----------------------------|----------------------------|----------------------------|----------------------------|
| Bit | 7 | 6 | 5 | 4 | 3 | 2 | 1 | 0 | 7 | 6 | 5 | 4 | 3 | 2 | 1 | 0 |
| | Extension port | | | | | | | | | | | | | | | |
| Description | Short-circuit Port 7 Pin 4 | Short-circuit Port 6 Pin 4 | Short-circuit Port 5 Pin 4 | Short-circuit Port 4 Pin 4 | Short-circuit Port 3 Pin 4 | Short-circuit Port 2 Pin 4 | Short-circuit Port 1 Pin 4 | Short-circuit Port 0 Pin 4 | Short-circuit Port 7 Pin 2 | Short-circuit Port 6 Pin 2 | Short-circuit Port 5 Pin 2 | Short-circuit Port 4 Pin 2 | Short-circuit Port 3 Pin 2 | Short-circuit Port 2 Pin 2 | Short-circuit Port 1 Pin 2 | Short-circuit Port 0 Pin 2 |

5 Configuration: extended with BNI IOL-302-S02-R026

5.3. Process Data/ Output Data Process data length of 4 bytes

| Byte | 0 | | | | | | | | 1 | | | | | | | |
|-------------|---|---------------------|---------------------|---------------------|---------------------|---------------------|---------------------|---------------------|---|---------------------|---------------------|---------------------|---------------------|---------------------|---------------------|---------------------|
| Bit | 7 | 6 | 5 | 4 | 3 | 2 | 1 | 0 | 7 | 6 | 5 | 4 | 3 | 2 | 1 | 0 |
| Description | - | Output Port 6 Pin 4 | Output Port 5 Pin 4 | Output Port 4 Pin 4 | Output Port 3 Pin 4 | Output Port 2 Pin 4 | Output Port 1 Pin 4 | Output Port 0 Pin 4 | - | Output Port 6 Pin 2 | Output Port 5 Pin 2 | Output Port 4 Pin 2 | Output Port 3 Pin 2 | Output Port 2 Pin 2 | Output Port 1 Pin 2 | Output Port 0 Pin 2 |

| Byte | 2 | | | | | | | | 3 | | | | | | | |
|-------------|---------------------|---------------------|---------------------|---------------------|---------------------|---------------------|---------------------|---------------------|---------------------|---------------------|---------------------|---------------------|---------------------|---------------------|---------------------|---------------------|
| Bit | 7 | 6 | 5 | 4 | 3 | 2 | 1 | 0 | 7 | 6 | 5 | 4 | 3 | 2 | 1 | 0 |
| | Extension port | | | | | | | | | | | | | | | |
| Description | Output Port 7 Pin 4 | Output Port 6 Pin 4 | Output Port 5 Pin 4 | Output Port 4 Pin 4 | Output Port 3 Pin 4 | Output Port 2 Pin 4 | Output Port 1 Pin 4 | Output Port 0 Pin 4 | Output Port 7 Pin 2 | Output Port 6 Pin 2 | Output Port 5 Pin 2 | Output Port 4 Pin 2 | Output Port 3 Pin 2 | Output Port 2 Pin 2 | Output Port 1 Pin 2 | Output Port 0 Pin 2 |

5.4. Parameter Data/Demand Data

| | DPP | SPDU | | Parameter | Data width | Access rights | Default value |
|---------------------|-------------------------|-------------------------|--------------------------|---------------|-------------|------------------|--|
| | Index | Index | Sub-index | | | | |
| Identification data | 07 ^{hex} 07 | | | Vendor ID | 2 bytes | Read only | 0378 ^{hex} |
| | 08 ^{hex} 08 | | | | | | |
| | 09 ^{hex} 09 | | | Device ID | 3 bytes | | 0x05 0B 21 |
| | 0A ^{hex} 10 | | | | | | |
| | 0B ^{hex} 11 | | | | | | |
| | | 10 ^{hex} 16 | 0 | Vendor name | 8 bytes | | BALLUFF |
| | | 11 ^{hex} 17 | 0 | Vendor text | 16 bytes | | www.balluff.com |
| | | 12 ^{hex} 18 | 0 | Product name | 20/24 bytes | | BNI IOL-302-S02-R026 with BNI IOL-302-S02-R026 |
| | | 13 ^{hex} 19 | 0 | Product ID | 7 bytes | | BNI0091 with BNI0091 |
| | | 14 ^{hex} 20 | 0 | Product text | 16 bytes | | M12 sensor/actuator hub |
| | | 15 ^{hex} 21 | 0 | Serial number | 16 bytes | | 0 ^{hex} |
| | 16 ^{hex} 22 | 0 | Hardware revision | | | | |
| | 17 ^{hex} 23 | 0 | Firmware revision | | | | |
| | 18 ^{hex} 24 | 0 | Application-specific tag | 32 bytes | | 0 ^{hex} | |

Parameter Data/Demand Data

| | DPP | SPDU | | Parameter | Data width | Access rights | Default Value |
|----------------|-------|-------------------------|-----------|-------------------------|------------|---------------|----------------------|
| | Index | Index | Subindex | | | | |
| Parameter data | | 40 ^{hex} 64 | 0 1-32 | Inversion of the inputs | 4 bytes | Read/write | 0 ^{hex} |
| | | 42 ^{hex} 66 | 0 1-16 | Safe state on Pin 4 | 4 bytes | Read/write | 0 ^{hex} |
| | | 43 ^{hex} 67 | 0 1-16 | Safe state on Pin 2 | 4 bytes | Read/write | 0 ^{hex} |
| | | 44 ^{hex} 68 | 0 1-32 | Voltage monitoring | 4 bytes | Read | - |
| | | 45 ^{hex} 69 | 0 1-32 | Output monitoring | 4 bytes | Read | - |
| | | 54 ^{hex} 84 | 0 | Serial number | 16 bytes | Read/write | 16x00 ^{hex} |
| | | 55 ^{hex} 85 | 0 | Extension port | 1 byte | Read/write | 1 ^{hex} |

5 Configuration: extended with BNI IOL-302-S02-R026

Inversion of the inputs 40_{hex}

| Byte | 0 | | | | | | | | 1 | | | | | | | |
|-------------|---|---------------------------|---------------------------|---------------------------|---------------------------|---------------------------|---------------------------|---------------------------|----|---------------------------|---------------------------|---------------------------|---------------------------|---------------------------|---------------------------|---------------------------|
| Bit | 7 | 6 | 5 | 4 | 3 | 2 | 1 | 0 | 7 | 6 | 5 | 4 | 3 | 2 | 1 | 0 |
| Sub-index | 8 | 7 | 6 | 5 | 4 | 3 | 2 | 1 | 16 | 15 | 14 | 13 | 12 | 11 | 10 | 9 |
| Description | - | Inversion of Port 6 Pin 4 | Inversion of Port 5 Pin 4 | Inversion of Port 4 Pin 4 | Inversion of Port 3 Pin 4 | Inversion of Port 2 Pin 4 | Inversion of Port 1 Pin 4 | Inversion of Port 0 Pin 4 | - | Inversion of Port 6 Pin 2 | Inversion of Port 5 Pin 2 | Inversion of Port 4 Pin 2 | Inversion of Port 3 Pin 2 | Inversion of Port 2 Pin 2 | Inversion of Port 1 Pin 2 | Inversion of Port 0 Pin 2 |

| Byte | 2 | | | | | | | | 3 | | | | | | | |
|-------------|---------------------------|---------------------------|---------------------------|---------------------------|---------------------------|---------------------------|---------------------------|---------------------------|---------------------------|---------------------------|---------------------------|---------------------------|---------------------------|---------------------------|---------------------------|---------------------------|
| Bit | 7 | 6 | 5 | 4 | 3 | 2 | 1 | 0 | 7 | 6 | 5 | 4 | 3 | 2 | 1 | 0 |
| Sub-index | 24 | 23 | 22 | 21 | 20 | 19 | 18 | 17 | 32 | 31 | 30 | 29 | 28 | 27 | 26 | 25 |
| | Extension port | | | | | | | | | | | | | | | |
| Description | Inversion of Port 7 Pin 4 | Inversion of Port 6 Pin 4 | Inversion of Port 5 Pin 4 | Inversion of Port 4 Pin 4 | Inversion of Port 3 Pin 4 | Inversion of Port 2 Pin 4 | Inversion of Port 1 Pin 4 | Inversion of Port 0 Pin 4 | Inversion of Port 7 Pin 2 | Inversion of Port 6 Pin 2 | Inversion of Port 5 Pin 2 | Inversion of Port 4 Pin 2 | Inversion of Port 3 Pin 2 | Inversion of Port 2 Pin 2 | Inversion of Port 1 Pin 2 | Inversion of Port 0 Pin 2 |

Inversion of port (x):
 0 - Normal
 1 - Inverted

5 Configuration: extended with BNI IOL-302-S02-R026

Safe state of Outputs 42_{hex}

The safe state parameter makes it possible to configure the outputs in case of a fault. If no IO-Link communication is possible or the "valid flag" of the output process data has not been set by the master, then each output adopts the configured status. The following statuses can be configured for each pin.

Safe state of the outputs on Pin 4, 42_{hex}

| Byte | 0 | | | | | | | | 1 | | | | | | | |
|-------------|-------------------------|---|-------------------------|---|-------------------------|---|-------------------------|---|-------------------------|---|-------------------------|---|-------------------------|---|-------------------------|---|
| | 7 | 6 | 5 | 4 | 3 | 2 | 1 | 0 | 7 | 6 | 5 | 4 | 3 | 2 | 1 | 0 |
| Sub-index | 4 | | 3 | | 2 | | 1 | | 8 | | 7 | | 6 | | 5 | |
| Description | Safe state Port 3 Pin 4 | | Safe state Port 2 Pin 4 | | Safe state Port 1 Pin 4 | | Safe state Port 0 Pin 4 | | Safe state Port 7 Pin 4 | | Safe state Port 6 Pin 4 | | Safe state Port 5 Pin 4 | | Safe state Port 4 Pin 4 | |

| Byte | 2 | | | | | | | | 3 | | | | | | | |
|-------------|-------------------------|---|-------------------------|---|-------------------------|---|-------------------------|---|----|---|-------------------------|---|-------------------------|---|-------------------------|---|
| | 7 | 6 | 5 | 4 | 3 | 2 | 1 | 0 | 7 | 6 | 5 | 4 | 3 | 2 | 1 | 0 |
| Sub-index | 12 | | 11 | | 10 | | 9 | | 16 | | 15 | | 14 | | 13 | |
| | Extension port | | | | | | | | | | | | | | | |
| Description | Safe state Port 3 Pin 4 | | Safe state Port 2 Pin 4 | | Safe state Port 1 Pin 4 | | Safe state Port 0 Pin 4 | | - | | Safe state Port 6 Pin 4 | | Safe state Port 5 Pin 4 | | Safe state Port 4 Pin 4 | |

5 Configuration: extended with BNI IOL-302-S02-R026

Safe state of the outputs on Pin 2, 43hex

| Byte | 0 | | | | | | | | 1 | | | | | | | |
|-------------|-------------------------|---|-------------------------|---|-------------------------|---|-------------------------|---|-------------------------|---|-------------------------|---|-------------------------|---|-------------------------|---|
| Bit | 7 | 6 | 5 | 4 | 3 | 2 | 1 | 0 | 7 | 6 | 5 | 4 | 3 | 2 | 1 | 0 |
| Sub-index | 4 | | 3 | | 2 | | 1 | | 8 | | 7 | | 6 | | 5 | |
| Description | Safe state Port 3 Pin 2 | | Safe state Port 2 Pin 2 | | Safe state Port 1 Pin 2 | | Safe state Port 0 Pin 2 | | Safe state Port 7 Pin 2 | | Safe state Port 6 Pin 2 | | Safe state Port 5 Pin 2 | | Safe state Port 4 Pin 2 | |

| Byte | 2 | | | | | | | | 3 | | | | | | | |
|-------------|-------------------------|---|-------------------------|---|-------------------------|---|-------------------------|---|----|---|-------------------------|---|-------------------------|---|-------------------------|---|
| Bit | 7 | 6 | 5 | 4 | 3 | 2 | 1 | 0 | 7 | 6 | 5 | 4 | 3 | 2 | 1 | 0 |
| Sub-index | 12 | | 11 | | 10 | | 9 | | 16 | | 15 | | 14 | | 13 | |
| Description | Safe state Port 3 Pin 2 | | Safe state Port 2 Pin 2 | | Safe state Port 1 Pin 2 | | Safe state Port 0 Pin 2 | | - | | Safe state Port 6 Pin 2 | | Safe state Port 5 Pin 2 | | Safe state Port 4 Pin 2 | |

| Value | | Output state |
|-------|-----|------------------------------|
| bin | dec | |
| 00 | 0 | Output is 0V |
| 01 | 1 | Output is 24V |
| 10 | 2 | Current status is maintained |
| 11 | 3 | Not permitted |

5 Configuration: extended with BNI IOL-302-S02-R026

Voltage monitoring
44hex

| Byte | 0 | | | | | | | | 1 | | | | | | | |
|-------------|----------------------------|----------------------------|----------------------------|----------------------------|----------------------------|----------------------------|----------------------------|----------------------------|----|----|----|----|--------------------------|-----------------|------------------|------------------|
| Bit | 7 | 6 | 5 | 4 | 3 | 2 | 1 | 0 | 7 | 6 | 5 | 4 | 3 | 2 | 1 | 0 |
| Sub-index | 8 | 7 | 6 | 5 | 4 | 3 | 2 | 1 | 16 | 15 | 14 | 13 | 12 | 11 | 10 | 9 |
| Description | Short-circuit Port 7 Pin 1 | Short-circuit Port 6 Pin 1 | Short-circuit Port 5 Pin 1 | Short-circuit Port 4 Pin 1 | Short-circuit Port 3 Pin 1 | Short-circuit Port 2 Pin 1 | Short-circuit Port 1 Pin 1 | Short-circuit Port 0 Pin 1 | - | - | - | - | Outputs off (UA too low) | Undervoltage UA | Undervoltage US2 | Undervoltage US1 |

| Byte | 2 | | | | | | | | 3 | | | | | | | |
|-----------------------|----------------------------|----------------------------|----------------------------|----------------------------|----------------------------|----------------------------|----------------------------|----------------------------|----|----|----|----|--------------------------|-----------------|------------------|------------------|
| Bit | 7 | 6 | 5 | 4 | 3 | 2 | 1 | 0 | 7 | 6 | 5 | 4 | 3 | 2 | 1 | 0 |
| Sub-index | 24 | 23 | 22 | 21 | 20 | 19 | 18 | 17 | 32 | 31 | 30 | 29 | 28 | 27 | 26 | 25 |
| Extension port | | | | | | | | | | | | | | | | |
| Description | Short-circuit Port 7 Pin 1 | Short-circuit Port 6 Pin 1 | Short-circuit Port 5 Pin 1 | Short-circuit Port 4 Pin 1 | Short-circuit Port 3 Pin 1 | Short-circuit Port 2 Pin 1 | Short-circuit Port 1 Pin 1 | Short-circuit Port 0 Pin 1 | - | - | - | - | Outputs off (UA too low) | Undervoltage UA | Undervoltage US2 | Undervoltage US1 |

Monitoring the outputs
45hex

| Byte | 0 | | | | | | | | 1 | | | | | | | |
|-------------|---|----------------------------|----------------------------|----------------------------|----------------------------|----------------------------|----------------------------|----------------------------|----|----------------------------|----------------------------|----------------------------|----------------------------|----------------------------|----------------------------|----------------------------|
| Bit | 7 | 6 | 5 | 4 | 3 | 2 | 1 | 0 | 7 | 6 | 5 | 4 | 3 | 2 | 1 | 0 |
| Sub-index | 8 | 7 | 6 | 5 | 4 | 3 | 2 | 1 | 16 | 15 | 14 | 13 | 12 | 11 | 10 | 9 |
| Description | - | Short-circuit Port 6 Pin 4 | Short-circuit Port 5 Pin 4 | Short-circuit Port 4 Pin 4 | Short-circuit Port 3 Pin 4 | Short-circuit Port 2 Pin 4 | Short-circuit Port 1 Pin 4 | Short-circuit Port 0 Pin 4 | - | Short-circuit Port 6 Pin 2 | Short-circuit Port 5 Pin 2 | Short-circuit Port 4 Pin 2 | Short-circuit Port 3 Pin 2 | Short-circuit Port 2 Pin 2 | Short-circuit Port 1 Pin 2 | Short-circuit Port 0 Pin 2 |

5 Configuration: extended with BNI IOL-302-S02-R026

| Byte | 2 | | | | | | | | 3 | | | | | | | |
|-------------|----------------------------|----------------------------|----------------------------|----------------------------|----------------------------|----------------------------|----------------------------|----------------------------|----------------------------|----------------------------|----------------------------|----------------------------|----------------------------|----------------------------|----------------------------|----------------------------|
| Bit | 7 | 6 | 5 | 4 | 3 | 2 | 1 | 0 | 7 | 6 | 5 | 4 | 3 | 2 | 1 | 0 |
| Sub-index | 24 | 23 | 22 | 21 | 20 | 19 | 18 | 17 | 32 | 31 | 30 | 29 | 28 | 27 | 26 | 25 |
| | Extension port | | | | | | | | | | | | | | | |
| Description | Short-circuit Port 7 Pin 4 | Short-circuit Port 6 Pin 4 | Short-circuit Port 5 Pin 4 | Short-circuit Port 4 Pin 4 | Short-circuit Port 3 Pin 4 | Short-circuit Port 2 Pin 4 | Short-circuit Port 1 Pin 4 | Short-circuit Port 0 Pin 4 | Short-circuit Port 7 Pin 2 | Short-circuit Port 6 Pin 2 | Short-circuit Port 5 Pin 2 | Short-circuit Port 4 Pin 2 | Short-circuit Port 3 Pin 2 | Short-circuit Port 2 Pin 2 | Short-circuit Port 1 Pin 2 | Short-circuit Port 0 Pin 2 |

Setting the serial number 54hex

The serial number has a default value of 16x00hex. In order to use the "Identity" master validation mode, a serial number can be set using this parameter. This prevents a device from connecting to the wrong master port.

6 Configuration Extended with Valve Terminal Connector with 22/24 Valves



6.1. IO-Link Data

| BNI IOL-302-S02-R026, extended with valve terminal connector with 22/24 valves | |
|---|-----------------------------|
| Transmission rate | COM2 (38.4 kbaud) |
| Minimum cycle time | 7.2 ms |
| Process data length | 6 byte input, 6 byte output |

6.2. Process Data/Input Data

Process data length of 6 bytes:

| Byte | 0 | | | | | | | | 1 | | | | | | | |
|-------------|---|--------------------|--------------------|--------------------|--------------------|--------------------|--------------------|--------------------|---|--------------------|--------------------|--------------------|--------------------|--------------------|--------------------|--------------------|
| | 7 | 6 | 5 | 4 | 3 | 2 | 1 | 0 | 7 | 6 | 5 | 4 | 3 | 2 | 1 | 0 |
| Description | - | Input Port 6 Pin 4 | Input Port 5 Pin 4 | Input Port 4 Pin 4 | Input Port 3 Pin 4 | Input Port 2 Pin 4 | Input Port 1 Pin 4 | Input Port 0 Pin 4 | - | Input Port 6 Pin 2 | Input Port 5 Pin 2 | Input Port 4 Pin 2 | Input Port 3 Pin 2 | Input Port 2 Pin 2 | Input Port 1 Pin 2 | Input Port 0 Pin 2 |

| Byte | 2 | | | | | | | | 3 | | | | | | | |
|-------------|---|----------------------|----------------------|----------------------|----------------------|----------------------|----------------------|----------------------|---|---|---|---|--------------------------|-----------------|------------------|------------------|
| | 7 | 6 | 5 | 4 | 3 | 2 | 1 | 0 | 7 | 6 | 5 | 4 | 3 | 2 | 1 | 0 |
| Description | - | Short-circuit Port 6 | Short-circuit Port 5 | Short-circuit Port 4 | Short-circuit Port 3 | Short-circuit Port 2 | Short-circuit Port 1 | Short-circuit Port 0 | - | - | - | - | Outputs off (UA too low) | Undervoltage UA | Undervoltage US2 | Undervoltage US1 |

6 Configuration Extended with Valve Terminal Connector with 22/24 Valves

| Byte | 4 | | | | | | | | 5 | | | | | | | |
|-------------|---|----------------------------|----------------------------|----------------------------|----------------------------|----------------------------|----------------------------|----------------------------|---|----------------------------|----------------------------|----------------------------|----------------------------|----------------------------|----------------------------|----------------------------|
| Bit | 7 | 6 | 5 | 4 | 3 | 2 | 1 | 0 | 7 | 6 | 5 | 4 | 3 | 2 | 1 | 0 |
| Description | - | Short-circuit Port 6 Pin 4 | Short-circuit Port 5 Pin 4 | Short-circuit Port 4 Pin 4 | Short-circuit Port 3 Pin 4 | Short-circuit Port 2 Pin 4 | Short-circuit Port 1 Pin 4 | Short-circuit Port 0 Pin 4 | - | Short-circuit Port 6 Pin 2 | Short-circuit Port 5 Pin 2 | Short-circuit Port 4 Pin 2 | Short-circuit Port 3 Pin 2 | Short-circuit Port 2 Pin 2 | Short-circuit Port 1 Pin 2 | Short-circuit Port 0 Pin 2 |

**6.3. Process Data/
Output Data**

Process data length of 6 bytes

| Byte | 0 | | | | | | | | 1 | | | | | | | |
|-------------|---------------------|---------------------|---------------------|---------------------|---------------------|---------------------|---------------------|---------------------|---------------------|---------------------|---------------------|---------------------|---------------------|---------------------|---------------------|---------------------|
| Bit | 7 | 6 | 5 | 4 | 3 | 2 | 1 | 0 | 7 | 6 | 5 | 4 | 3 | 2 | 1 | 0 |
| Description | Output Port 7 Pin 4 | Output Port 6 Pin 4 | Output Port 5 Pin 4 | Output Port 4 Pin 4 | Output Port 3 Pin 4 | Output Port 2 Pin 4 | Output Port 1 Pin 4 | Output Port 0 Pin 4 | Output Port 7 Pin 2 | Output Port 6 Pin 2 | Output Port 5 Pin 2 | Output Port 4 Pin 2 | Output Port 3 Pin 2 | Output Port 2 Pin 2 | Output Port 1 Pin 2 | Output Port 0 Pin 2 |

6 Configuration Extended with Valve Terminal Connector with 22/24 Valves

| Byte | 2 | | | | | | | | 3 | | | | | | | |
|--------------------|---|---|---|---|---------------------|-------------------|-------------------|-------------------|-------------------|-------------------|-------------------|-------------------|-------------------|-------------------|-------------------|-------------------|
| Bit | 7 | 6 | 5 | 4 | 3 | 2 | 1 | 0 | 7 | 6 | 5 | 4 | 3 | 2 | 1 | 0 |
| | Valve terminal on extension port | | | | | | | | | | | | | | | |
| Description | . | . | . | . | * Valve 12 – Coil A | Valve 11 – Coil A | Valve 10 – Coil A | Valve 09 – Coil A | Valve 08 – Coil A | Valve 07 – Coil A | Valve 06 – Coil A | Valve 05 – Coil A | Valve 04 – Coil A | Valve 03 – Coil A | Valve 02 – Coil A | Valve 01 – Coil A |

* No function for V013

| Byte | 4 | | | | | | | | 5 | | | | | | | |
|--------------------|---|---|---|---|---------------------|-------------------|-------------------|-------------------|-------------------|-------------------|-------------------|-------------------|-------------------|-------------------|-------------------|-------------------|
| Bit | 7 | 6 | 5 | 4 | 3 | 2 | 1 | 0 | 7 | 6 | 5 | 4 | 3 | 2 | 1 | 0 |
| | Valve terminal on extension port | | | | | | | | | | | | | | | |
| Description | . | . | . | . | * Valve 12 – Coil B | Valve 11 – Coil B | Valve 10 – Coil B | Valve 09 – Coil B | Valve 08 – Coil B | Valve 07 – Coil B | Valve 06 – Coil B | Valve 05 – Coil B | Valve 04 – Coil B | Valve 03 – Coil B | Valve 02 – Coil B | Valve 01 – Coil B |

* No function for V013

6 Configuration Extended with Valve Terminal Connector with 22/24 Valves

6.4. Parameter Data/Demand Data

| | DPP | | SPDU | | Parameter | Data width | Access rights | Default value |
|----------------------------|-------------------------|-------------------------|-----------|--------------------------|-------------------|------------------|---------------|--|
| | Index | Index | Sub-index | Sub-index | | | | |
| Identification data | 07 ^{hex} 07 | | | | Vendor ID | 2 bytes | Read only | 0378 ^{hex} |
| | 08 ^{hex} 08 | | | | | | | |
| | 09 ^{hex} 09 | | | | Device ID | 3 bytes | | 0x05 0B 22 0x05 0B 23 0x05 0B 24 |
| | 0A ^{hex} 10 | | | | | | | |
| | 0B ^{hex} 11 | | | | | | | |
| | | 10 ^{hex} 16 | | 0 | Vendor name | 8 bytes | | BALLUFF |
| | | 11 ^{hex} 17 | | 0 | Vendor text | 16 bytes | | www.balluff.com |
| | | 12 ^{hex} 18 | | 0 | Product name | 20/24 bytes | | BNI IOL-302-S02-R026 with BNI IOL-751-V08-K007 BNI IOL-302-S02-R026 with BNI IOL-751-V10-K007 BNI IOL-302-S02-R026 with BNI IOL-751-V13-K007 |
| | | 13 ^{hex} 19 | | 0 | Product ID | 7 bytes | | BNI0091 with BNI006N with BNI006P with BNI006R |
| | | 14 ^{hex} 20 | | 0 | Product text | 16 bytes | | Sensor/actuator hub M12 with expanded BNI IOL-751-V08-K007 Sensor/actuator hub M12 with expanded BNI IOL-751-V10-K007 Sensor/actuator hub M12 with expanded BNI IOL-751-V13-K007 |
| | | 15 ^{hex} 21 | | 0 | Serial number | 16 bytes | | 0 ^{hex} |
| | | 16 ^{hex} 22 | | 0 | Hardware revision | | | |
| | 17 ^{hex} 23 | | 0 | Firmware revision | | | | |
| | 18 ^{hex} 24 | | 0 | Application-specific tag | 32 bytes | 0 ^{hex} | | |

Parameter Data/Demand Data

| | DPP | | SPDU | | Parameter | Data width | Access rights | Default Value |
|-----------------------|-------|-------------------------|----------|-----------|-------------------------|------------|---------------|------------------------|
| | Index | Index | Subindex | Subindex | | | | |
| Parameter data | | 40 ^{hex} 64 | | 0 1-16 | Inversion of the inputs | 2 bytes | Read/write | 0 ^{hex} |
| | | 42 ^{hex} 66 | | 0 1-32 | Safe state on Pin 4 | 10 bytes | Read/write | 0 ^{hex} |
| | | 43 ^{hex} 67 | | 0 1-8 | Safe state on Pin 2 | 2 bytes | Read/write | 0 ^{hex} |
| | | 44 ^{hex} 68 | | 0 1-23 | Voltage monitoring | 3 bytes | Read | - |
| | | 45 ^{hex} 69 | | 0 1-40 | Output monitoring | 6 bytes | Read | - |
| | | 54 ^{hex} 84 | | 0 | Serial number | 16 bytes | Read/write | 16x00 ^{hex} |
| | | 55 ^{hex} 85 | | 0 | Extension port | 1 byte | Read/write | 2, 3, 4 ^{hex} |

6 Configuration Extended with Valve Terminal Connector with 22/24 Valves

Inversion of the inputs 40_{hex}

| Byte | 0 | | | | | | | | 1 | | | | | | | |
|-------------|---|---------------------------|---------------------------|---------------------------|---------------------------|---------------------------|---------------------------|---------------------------|----|---------------------------|---------------------------|---------------------------|---------------------------|---------------------------|---------------------------|---------------------------|
| Bit | 7 | 6 | 5 | 4 | 3 | 2 | 1 | 0 | 7 | 6 | 5 | 4 | 3 | 2 | 1 | 0 |
| Sub-index | 8 | 7 | 6 | 5 | 4 | 3 | 2 | 1 | 16 | 15 | 14 | 13 | 12 | 11 | 10 | 9 |
| Description | - | Inversion of Port 6 Pin 4 | Inversion of Port 5 Pin 4 | Inversion of Port 4 Pin 4 | Inversion of Port 3 Pin 4 | Inversion of Port 2 Pin 4 | Inversion of Port 1 Pin 4 | Inversion of Port 0 Pin 4 | - | Inversion of Port 6 Pin 2 | Inversion of Port 5 Pin 2 | Inversion of Port 4 Pin 2 | Inversion of Port 3 Pin 2 | Inversion of Port 2 Pin 2 | Inversion of Port 1 Pin 2 | Inversion of Port 0 Pin 2 |

Inversion of port (x):

0 - Normal

1 - Inverted

6 Configuration Extended with Valve Terminal Connector with 22/24 Valves

Safe state of Outputs 42hex

The safe state parameter makes it possible to configure the outputs in case of a fault. If no IO-Link communication is possible or the "valid flag" of the output process data has not been set by the master, then each output adopts the configured status. The following statuses can be configured for each pin.

Safe state of the Outputs Pin 4, 42hex

| Byte | 0 | | | | | | | | 1 | | | | | | | |
|-------------|-------------------------|---|-------------------------|---|-------------------------|---|-------------------------|---|---|---|-------------------------|---|-------------------------|---|-------------------------|---|
| Bit | 7 | 6 | 5 | 4 | 3 | 2 | 1 | 0 | 7 | 6 | 5 | 4 | 3 | 2 | 1 | 0 |
| Sub-index | 4 | | 3 | | 2 | | 1 | | 8 | | 7 | | 6 | | 5 | |
| Description | Safe state Port 3 Pin 4 | | Safe state Port 2 Pin 4 | | Safe state Port 1 Pin 4 | | Safe state Port 0 Pin 4 | | - | | Safe state Port 6 Pin 4 | | Safe state Port 5 Pin 4 | | Safe state Port 4 Pin 4 | |

| Byte | 2 | | | | | | | | 3 | | | | | | | |
|---|---|---|---|---|---|---|---|---|---------------------|---|-------------------|---|-------------------|---|-------------------|---|
| Bit | 7 | 6 | 5 | 4 | 3 | 2 | 1 | 0 | 7 | 6 | 5 | 4 | 3 | 2 | 1 | 0 |
| Sub-index | | | | | | | | | 31 | | 29 | | 27 | | 25 | |
| Valve terminal on extension port | | | | | | | | | | | | | | | | |
| Description | - | | - | | - | | - | | * Valve 12 – Coil A | | Valve 11 – Coil A | | Valve 10 – Coil A | | Valve 09 – Coil A | |

* No function for V013

| Byte | 4 | | | | | | | | 5 | | | | | | | |
|---|-------------------|---|-------------------|---|-------------------|---|-------------------|---|-------------------|---|-------------------|---|-------------------|---|-------------------|---|
| Bit | 7 | 6 | 5 | 4 | 3 | 2 | 1 | 0 | 7 | 6 | 5 | 4 | 3 | 2 | 1 | 0 |
| Sub-index | 23 | | 21 | | 19 | | 17 | | 15 | | 13 | | 11 | | 9 | |
| Valve terminal on extension port | | | | | | | | | | | | | | | | |
| Description | Valve 08 – Coil A | | Valve 07 – Coil A | | Valve 06 – Coil A | | Valve 05 – Coil A | | Valve 04 – Coil A | | Valve 03 – Coil A | | Valve 02 – Coil A | | Valve 01 – Coil A | |

6 Configuration Extended with Valve Terminal Connector with 22/24 Valves

| Byte | 6 | | | | | | | | 7 | | | | | | | |
|--------------------|---|---|---|---|---|---|---|---|---------------------|---|-------------------|---|-------------------|---|-------------------|---|
| Bit | 7 | 6 | 5 | 4 | 3 | 2 | 1 | 0 | 7 | 6 | 5 | 4 | 3 | 2 | 1 | 0 |
| Sub Index | | | | | | | | | 32 | | 30 | | 28 | | 26 | |
| | Valve terminal on extension port | | | | | | | | | | | | | | | |
| Description | | | | | | | | | * Valve 12 – Coil B | | Valve 11 – Coil B | | Valve 10 – Coil B | | Valve 09 – Coil B | |

* No function for V013

| Byte | 8 | | | | | | | | 9 | | | | | | | |
|--------------------|---|---|-------------------|---|-------------------|---|-------------------|---|-------------------|---|-------------------|---|-------------------|---|-------------------|---|
| Bit | 7 | 6 | 5 | 4 | 3 | 2 | 1 | 0 | 7 | 6 | 5 | 4 | 3 | 2 | 1 | 0 |
| Sub Index | 24 | | 22 | | 20 | | 18 | | 16 | | 14 | | 12 | | 10 | |
| | Valve terminal on extension port | | | | | | | | | | | | | | | |
| Description | Valve 08 – Coil B | | Valve 07 – Coil B | | Valve 06 – Coil B | | Valve 05 – Coil B | | Valve 04 – Coil B | | Valve 03 – Coil B | | Valve 02 – Coil B | | Valve 01 – Coil B | |

Safe state of the outputs on Pin 2, 43_{hex}

| Byte | 0 | | | | | | | | 1 | | | | | | | |
|--------------------|-------------------------|---|-------------------------|---|-------------------------|---|-------------------------|---|---|---|-------------------------|---|-------------------------|---|-------------------------|---|
| Bit | 7 | 6 | 5 | 4 | 3 | 2 | 1 | 0 | 7 | 6 | 5 | 4 | 3 | 2 | 1 | 0 |
| Sub Index | 4 | | 3 | | 2 | | 1 | | 8 | | 7 | | 6 | | 5 | |
| Description | Safe state Port 3 Pin 2 | | Safe state Port 2 Pin 2 | | Safe state Port 1 Pin 2 | | Safe state Port 0 Pin 2 | | | | Safe state Port 6 Pin 2 | | Safe state Port 5 Pin 2 | | Safe state Port 4 Pin 2 | |

| Value | | Output state |
|-------|-----|------------------------------|
| bin | dec | |
| 00 | 0 | Output is 0V |
| 01 | 1 | Output is 24V |
| 10 | 2 | Current status is maintained |
| 11 | 3 | Not defined |

6 Configuration Extended with Valve Terminal Connector with 22/24 Valves

Voltage monitoring
44hex

| Byte | 0 | | | | | | | | 1 | | | | | | | |
|-------------|----------------------------|----------------------------|----------------------------|----------------------------|----------------------------|----------------------------|----------------------------|----------------------------|----|----|----|----|--------------------------|-----------------|------------------|------------------|
| Bit | 7 | 6 | 5 | 4 | 3 | 2 | 1 | 0 | 7 | 6 | 5 | 4 | 3 | 2 | 1 | 0 |
| Sub-index | 8 | 7 | 6 | 5 | 4 | 3 | 2 | 1 | 16 | 15 | 14 | 13 | 12 | 11 | 10 | 9 |
| Description | Short-circuit Port 7 Pin 1 | Short-circuit Port 6 Pin 1 | Short-circuit Port 5 Pin 1 | Short-circuit Port 4 Pin 1 | Short-circuit Port 3 Pin 1 | Short-circuit Port 2 Pin 1 | Short-circuit Port 1 Pin 1 | Short-circuit Port 0 Pin 1 | - | - | - | - | Outputs off (UA too low) | Undervoltage UA | Undervoltage US2 | Undervoltage US1 |

| Byte | 2 | | | | | | | |
|-------------|----------------------------------|-------------|---|---|---|-----------------|---|-----------------|
| Bit | 7 | 6 | 5 | 4 | 3 | 2 | 1 | 0 |
| Sub-Index | | 23 | | | | 19 | | 17 |
| | Valve terminal on extension port | | | | | | | |
| Description | - | Overload UA | - | - | - | Undervoltage UA | - | Undervoltage US |

6 Configuration Extended with Valve Terminal Connector with 22/24 Valves

Monitoring the outputs
45hex

| Byte | 0 | | | | | | | | 1 | | | | | | | |
|-------------|----------------------------|----------------------------|----------------------------|----------------------------|----------------------------|----------------------------|----------------------------|----------------------------|----------------------------|----------------------------|----------------------------|----------------------------|----------------------------|----------------------------|----------------------------|----------------------------|
| Bit | 7 | 6 | 5 | 4 | 3 | 2 | 1 | 0 | 7 | 6 | 5 | 4 | 3 | 2 | 1 | 0 |
| Sub-index | 8 | 7 | 6 | 5 | 4 | 3 | 2 | 1 | 16 | 15 | 14 | 13 | 12 | 11 | 10 | 9 |
| Description | Short-circuit Port 7 Pin 4 | Short-circuit Port 6 Pin 4 | Short-circuit Port 5 Pin 4 | Short-circuit Port 4 Pin 4 | Short-circuit Port 3 Pin 4 | Short-circuit Port 2 Pin 4 | Short-circuit Port 1 Pin 4 | Short-circuit Port 0 Pin 4 | Short-circuit Port 7 Pin 2 | Short-circuit Port 6 Pin 2 | Short-circuit Port 5 Pin 2 | Short-circuit Port 4 Pin 2 | Short-circuit Port 3 Pin 2 | Short-circuit Port 2 Pin 2 | Short-circuit Port 1 Pin 2 | Short-circuit Port 0 Pin 2 |

| Byte | 2 | | | | | | | | 3 | | | | | | | |
|----------------|---|---|---|---|---------------------|-------------------|-------------------|-------------------|-------------------|-------------------|-------------------|-------------------|-------------------|-------------------|-------------------|-------------------|
| Bit | 7 | 6 | 5 | 4 | 3 | 2 | 1 | 0 | 7 | 6 | 5 | 4 | 3 | 2 | 1 | 0 |
| Sub-Index | | | | | 39 | 37 | 35 | 33 | 31 | 29 | 27 | 25 | 23 | 21 | 19 | 17 |
| Extension port | | | | | | | | | | | | | | | | |
| Description | . | . | . | . | * Valve 12 – Coil A | Valve 11 – Coil A | Valve 10 – Coil A | Valve 09 – Coil A | Valve 08 – Coil A | Valve 07 – Coil A | Valve 06 – Coil A | Valve 05 – Coil A | Valve 04 – Coil A | Valve 03 – Coil A | Valve 02 – Coil A | Valve 01 – Coil A |

* No function for V013

| Byte | 4 | | | | | | | | 5 | | | | | | | |
|----------------|---|---|---|---|---------------------|-------------------|-------------------|-------------------|-------------------|-------------------|-------------------|-------------------|-------------------|-------------------|-------------------|-------------------|
| Bit | 7 | 6 | 5 | 4 | 3 | 2 | 1 | 0 | 7 | 6 | 5 | 4 | 3 | 2 | 1 | 0 |
| Sub-Index | | | | | 40 | 38 | 36 | 34 | 32 | 30 | 28 | 26 | 24 | 22 | 20 | 18 |
| Extension port | | | | | | | | | | | | | | | | |
| Description | . | . | . | . | * Valve 12 – Coil B | Valve 11 – Coil B | Valve 10 – Coil B | Valve 09 – Coil B | Valve 08 – Coil B | Valve 07 – Coil B | Valve 06 – Coil B | Valve 05 – Coil B | Valve 04 – Coil B | Valve 03 – Coil B | Valve 02 – Coil B | Valve 01 – Coil B |

* No function for V013

Setting the serial number
54hex

The serial number has a default value of 16x00hex. In order to use the "Identity" master validation mode, a serial number can be set using this parameter. This prevents a device from connecting to the wrong master port.

6 Configuration Extended with Valve Terminal Connector with 22/24 Valves

**6.5. Error Codes/
Errors**

| Error code | Description |
|------------|------------------------------------|
| 0x8011 | Index not available |
| 0x8012 | Subindex not available |
| 0x8023 | Access denied |
| 0x8033 | Parameter length overrun |
| 0x8034 | Parameter length underrun |
| 0x8035 | Function not available |
| 0x8036 | Function temporarily not available |

6.6. Events

| IO-Link Revision 1.0 | |
|----------------------|------------------------------------|
| Event code | Description |
| 0x5112 | Low sensor voltage (US) |
| 0x5114 | Low actuator voltage (UA) |
| 0x5410 | Output stages |
| 0x8DF0 | Retry at the extension port |
| 0x8DF1 | Device lost at the extension port |
| 0x8DF2 | Wrong device at the extension port |
| IO-Link Revision 1.1 | |
| Event code | Description |
| 0x5111 | Low sensor voltage (US) |
| 0x5112 | Low actuator voltage (UA) |
| 0x7710 | Short circuit |
| 0x8DF0 | Retry at the extension port |
| 0x8DF1 | Device lost at the extension port |
| 0x8DF2 | Wrong device at the extension port |

7 IO-Link Functions

- 7.1. IO-Link Version 1.0 / 1.1** This device can be operated with an IO-Link master according to IO-Link version 1.0 and version 1.1. Version-specific functions such as data storage (version 1.1) are only supported in combination with a suitable IO-Link master.
- 7.2. Data Storage** Each IO-Link master of IO-Link version 1.1 features data storage in which an image of the IO-Link device configuration can be stored. When a device is replaced, the stored configuration is automatically transferred to the new device. This guarantees minimal downtime. Validation must be switched on in order to use the data storage. For information about the configuration of data storage and validation, please refer to the user's guide of the respective IO-Link master.
- 7.3. Block Configuration** The device supports block configuration. This allows all parameters in a data block to be consistently imported from a controller or a configuration tool into the device.
- 7.4. Resetting to Factory Settings** The factory settings on the device can be restored by running the "restore factory settings" system command. 0x82 must be written to Index 2 Subindex 0 for the command. The extension port setting is not reset in this process.

8 Technical Data

8.1. Dimensions

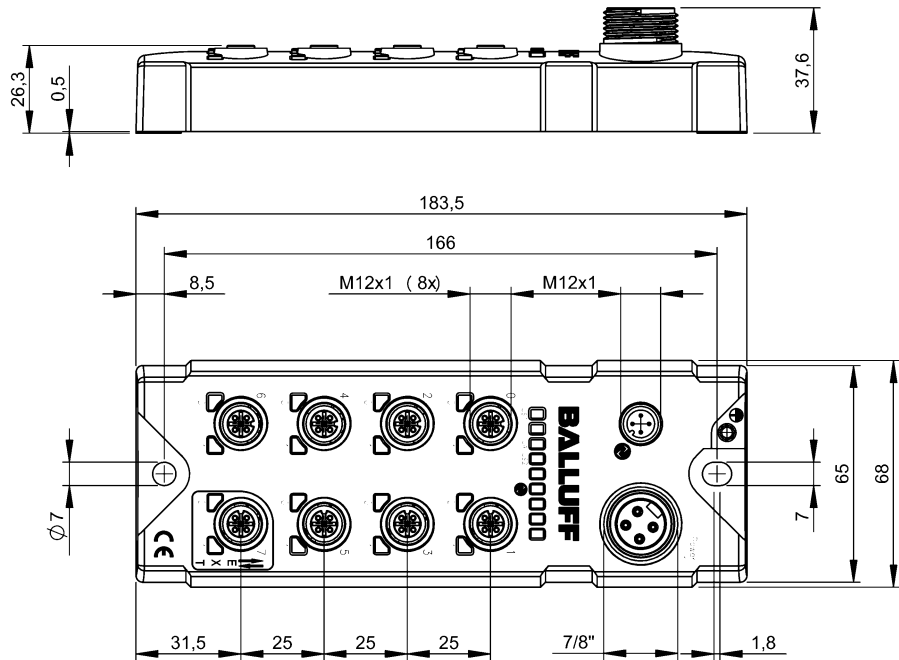

8.2. Mechanical Data

| | |
|--|-------------------------------------|
| Housing material | Plastic, resistant, Fortron 6165 A6 |
| IO-Link Port | IO-Link port M12, A-coded, male |
| I/O ports | M12x1, A-coded, female (8 piece) |
| Weight | 430 g |
| Dimension (L x W x H, without connector) | 183.5 x 68 x 37.6 mm |

8.3. Electrical Data

| | |
|-----------------------------------|---|
| Supply voltage | 18-30.2 V DC, corresponding to EN 61131-2 |
| Ripple | < 1% |
| Current consumption without load | ≤ 65 mA |
| Load current (PIN 1) | Max. 200 mA (temperature-dependent) |
| Load current per output (PIN 2.4) | max. 2 A (temperature-dependent) |
| Inputs | PNP, type 3 |

8.4. Operating conditions

| | |
|----------------------|---|
| Ambient temperature | -5 °C ... +70 °C |
| Storage temperature | -25 °C ... +70 °C |
| Degree of protection | IP67 (only in plugged-in and screwed state) |

9 Function Indicators

9.1. Function Indicators

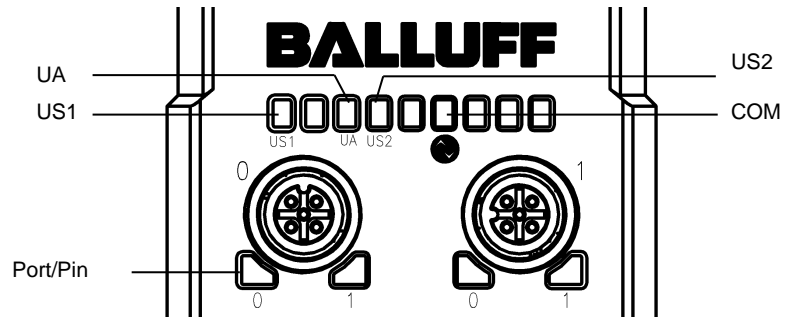

Port/Pin-LEDs

LED „0“- Port Pin 4
LED „1“- Port Pin 2

LED indicator module status

| | Indicator | Function |
|----------------|--------------------------|-----------------------------|
| COM | Green | No communication |
| | Green, negatively pulsed | Communication OK |
| US1 LED | Green | Sensor power supply is OK |
| | Red | Undervoltage < 18 V |
| UA LED | Green | Actuator power supply is OK |
| | Red | Undervoltage < 18 V |
| US2 LED | - | - |

9 Function Indicators

Digital LED indicators for inputs/outputs

LED 2, input/output on Pin 4 and LED 1, input/output on Pin 2

| Indicator | Request / Signal |
|-----------|--|
| Yellow | Input/output signal = 1 |
| Red | Sensor power supply short-circuit, Actuator warning Actuator short-circuit |
| Off | Input/output signal = 0 |

Extension port

The table is valid if the extension port is active. If the extension port is used as a standard I/O, then the description from "Digital LED indicators for inputs/outputs" can be used.

| Status | Function |
|---------------------|---|
| Green | IO-Link – connection active |
| Green, flashing | No IO-Link connection or faulty IO-Link device |
| Quick, red flashing | Incorrect IO-Link device or incorrect configuration |
| Red | IO-Link short-circuit on Pin 4 |

10.1. Type Code

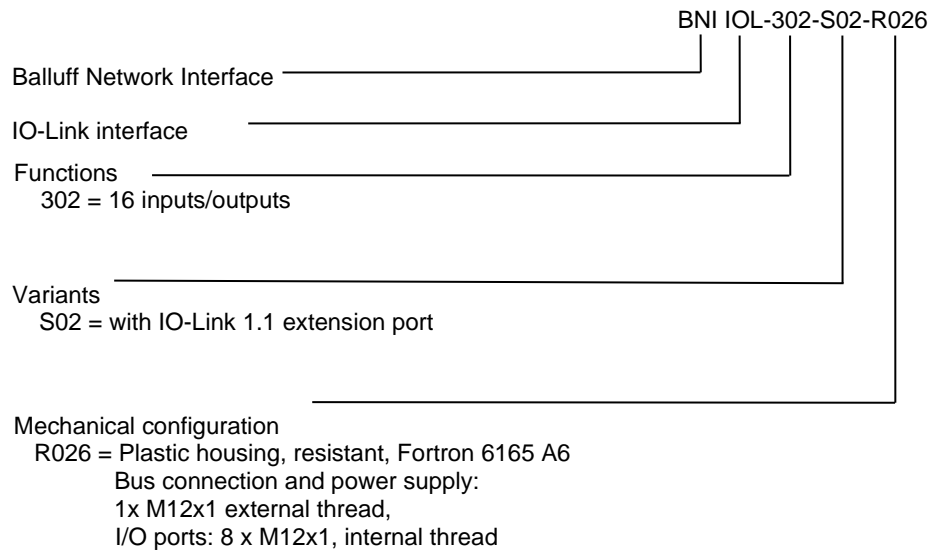

10.2. Ordering Information

| Type code | Order code |
|----------------------|------------|
| BNI IOL-302-S02-R026 | BNI0091 |

www.balluff.com

Balluff GmbH
Schurwaldstrasse 9
73765 Neuhausen a.d.F.
Germany
Phone +49 7158 173-0
Fax +49 7158 5010
balluff@balluff.de