

BALLUFF

sensors worldwide

BIC IO-Link unidirectional 500 mA, IP67 User's Guide

 **IO-Link**



English

Balluff Inductive Coupler

Base BIC 1I0-I2A50-M30MI3-SM4A4A and Remote BIC 2I0-I2A50-M30MI3-SM4A5A

Contents

1	User instructions	2
1.1	Validity of the Guide	2
1.2	Typographical Conventions	2
1.3	Symbols	2
1.4	Abbreviations	2
2	Safety	3
2.1	Proper use	3
2.2	Authorized Personnel	3
2.3	Obligations of the Operating Company	3
2.4	Malfunctions	3
2.5	Meaning of the warning notes	3
2.6	Certification	3
3	Construction and Function	4
3.1	Construction	4
3.2	Function	4
3.3	Features, Advantages	4
3.4	Indicators	4
4	Function indicator and diagnosis	5
4.1	Base indicators	5
4.2	Remote indicators	5
5	Installation and Connection	6
5.1	Mutual Interference	6
5.2	Installation in metal	6
5.3	Angular offset	7
5.4	Connection	7
5.5	Series connection	7
6	Technical data for "Base"	8
6.1	Dimension	8
6.2	Mechanical data	8
6.3	Operating conditions	8
6.4	Electrical data	8
6.5	Electrical connection	8
7	Technical data for "Remote"	9
7.1	Dimension	9
7.2	Mechanical data	9
7.3	Operating conditions	9
7.4	Electrical data	9
7.5	Electrical connections M12, 5-pin, socket	9
8	IO-Link communication	10
8.1	Process data	10
8.2	Parameters	11
8.3	Events	11
9	Accessories	12
9.1	Connectors	12
9.2	Installation accessories	12
9.3	Active components	12
10	Type code	13
10.1	Type Code	13
10.2	Order code	13

Balluff Inductive Coupler

Base BIC 110-I2A50-M30MI3-SM4A4A and Remote BIC 210-I2A50-M30MI3-SM4A5A

1 User instructions

1.1 Validity of the Guide This manual describes the structure, function and installation of the Balluff Uni-Standard inductive coupler. It is valid for types:
Base BIC 110-I2A50-M30MI3-SM4A4A and
Remote BIC 210-I2A50-M30MI3-SM4A5A (see type code)

The guide is intended for qualified technical personnel. Read the guide before you install and operate the devices.

1.2 Typographical Conventions The following typographical conventions are used in this guide.

Enumerations Enumerations are shown as a list with an en-dash.
- Entry 1
- Entry 2

Syntax Numbers
- Decimal numbers are shown without additional indicators (e.g. 123),
- Hexadecimal numbers are shown with the additional indicator hex (e.g. 00hex).

Cross-references Cross-references indicate where additional information on the topic can be found: (see Chap. 5, Section "Technical data").

1.3 Symbols



Note, tip

This symbol indicates general notes.



Caution!

This symbol indicates a safety instruction that must be followed without exception.



IO-Link

This device is IO-Link-capable

1.4 Abbreviations

BIC Balluff Inductive Coupler
EMC Electromagnetic Compatibility
FE Function Ground

Balluff Inductive Coupler

Base BIC 110-I2A50-M30MI3-SM4A4A and Remote BIC 210-I2A50-M30MI3-SM4A5A

2 Safety



Important!

Before commissioning, carefully read the operating manual.

2.1 Proper use

The device is designed to replace a plug connection in order to ensure contact-free data transmission.
The system must not be used in applications in which the safety of persons is dependent on the function of the device.
Warranty and liability claims against the manufacturer are rendered void by:

- Unauthorized tampering
- Improper use
- Use, installation or handling contrary to the instructions provided in this operating manual

2.2 Authorized Personnel

Installation and commissioning may only be performed by trained specialist personnel.

2.3 Obligations of the Operating Company

The operating company must ensure that the locally applicable safety regulations are observed.
The device corresponds to EMC Class A and can cause radio interference. The operating company must take appropriate precautions to prevent radio interference.
The device may only be used with an approved power supply. (see "Technical Data"). Only approved cables may be used.

2.4 Malfunctions

In the event of defects and device malfunctions that cannot be rectified, the device must be taken out of operation and protected against unauthorized use.

2.5 Meaning of the warning notes

The warning notices in this guide and the measures described for avoiding dangers must be observed.
The warning notices contain the following signal words that indicate the severity of the danger:

- **Danger:**
Indicates an immediate danger that will result in a severe injury or death of persons if not observed.
- **Warning:**
Indicates a potential danger that may result in a severe injury or death of persons if not observed.
- **Caution:**
Indicates a potential danger that may result in light injury to persons or damage to property if not avoided.
- **Caution:**
Indicates a situation that may result in property damage if not avoided.

When working with this product, the following warning notices apply:



Caution!

Risk of burning on hot surfaces! The active surface heats up even under normal operating conditions. Keep away hands and objects from the active surface.
Avoid contact of metal objects on the active surface. Fire hazard!

2.6 Certification



With the CE marking, we confirm that our products meet the requirements of EC directives 2004/108/EC (EMC) and the EMC law.

In our EMC laboratory, which is accredited by DATech for testing electromagnetic compatibility, evidence has been provided that the Balluff products satisfy the EMC requirements of the generic standards: EN 61000-6-4 (interference emission) and EN 61000-6-2 (interference immunity)

Balluff Inductive Coupler

Base BIC 110-I2A50-M30MI3-SM4A4A and Remote BIC 210-I2A50-M30MI3-SM4A5A

3 Construction and Function

3.1 Construction

The BIC components are designed for applications in an IO-Link system. They are connected to the host master module via the IO-Link protocol. The system consists of the following two components:

- Base (master side)
- Remote (device)

The components are enclosed in a brass housing protected acc. to IP 67

Master

The master is connected to the base.

Devices

The remote is connected to the device.

When IO-Link devices are connected, observe the following:

- Make certain that the total power consumption is not greater than that of the base.
- Use only devices with inputs

3.2 Function

This set transfers power from the base to the remote via an air bridge; the base then receives IO-Link data back from the remote. The base and remote must match one another with respect to size.

The IO-Link device is wired to the remote. The remote is only inductively coupled to the base, however. The base transmits the energy for the IO-Link device to the remote. The IO-Link communication of the IO-Link device is transmitted from the remote to the base. The energy available for the IO-Link device is dependent on the distance and on the offset between base and remote and is, therefore, limited. For this reason, the total current consumption of the connected IO-Link device must not exceed the maximum power output of the remote.

3.3 Features, Advantages

- The cable length between the remote and IO-Link device can be a maximum of 20 meters.
- LED indicator on the remote and base for operational readiness and operating voltage
- An angular offset is possible between base and remote
- Simple wiring of e.g. rotary tables, replaceable punch heads etc.
- M12 plug connection on the systems
- Control of capacitive loads
- More power in the same structural shape
- Large operating voltage range

3.4 Indicators

If the supply voltage is applied correctly, the green LEDs on the base and remote illuminate. If the IO-Link communication is active, the green LED on the base flashes inversely. The base's red LED illuminates as soon as an error has been detected in the system. As soon as the remote moves out of the secured working range, the red LEDs on the base begin to flash. If the red LED illuminates and stays on, there is an error in the IO-Link communication. If no device is connected to the remote but the remote is within range of the base, the green LEDs flash.

Balluff Inductive Coupler

Base BIC 1I0-I2A50-M30MI3-SM4A4A and Remote BIC 2I0-I2A50-M30MI3-SM4A5A

4 Function indicator and diagnosis

4.1 Base indicators

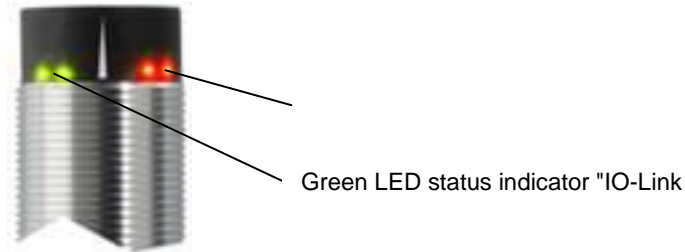

Signaling	Function
Green, static	Supply voltage OK No IO-Link communication
Green, flashing inversely	IO-Link communication between master and base is OK
Red, flashing	No remote detected
Red off	Remote present, IO-Link communication OK
Red, static	Remote present, no IO-Link communication to connected device

4.2 Remote indicators

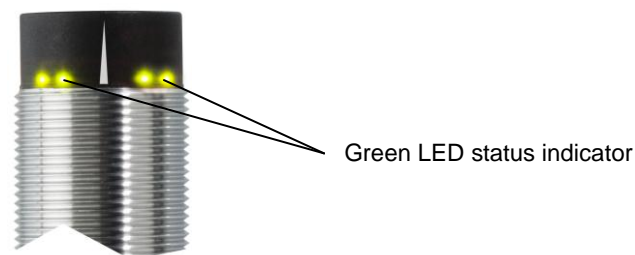

Signaling	Function
Green – static	The remote is located within the working range of a base, communication between the remote and IO-Link device is OK
Green, flashing	No IO-Link device present

Balluff Inductive Coupler

Base BIC 110-I2A50-M30MI3-SM4A4A and Remote BIC 210-I2A50-M30MI3-SM4A5A

5 Installation and Connection

5.1 Mutual Interference



Caution!

Improper mounting may affect the function of the system and lead to damage. The spacings specified for installation must be adhered to.

To prevent mutual interference with adjacent bases or remotes, the specified minimum distances must be adhered to:

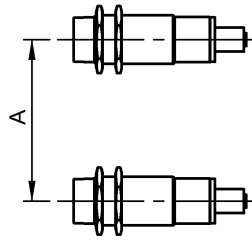

Type	A (mm)
BIC 110-I2A50-M30MI3-SM4A4A	100
BIC 210-I2A50-M30MI3-SM4A5A	100

5.2 Installation in metal



Caution!

Device damage due to induction effects
Metallic objects on the coil cap cause the objects to be heated.
Install the components so that no metallic objects can collect on the coil cap.
There is a fire hazard!

When installing in metal, the specified minimum distances to the surrounding sides of the metallic object must be maintained. Otherwise, the transmission distance between transmitter and receiver changes.

The transmission distance can also be influenced by the type of metal.

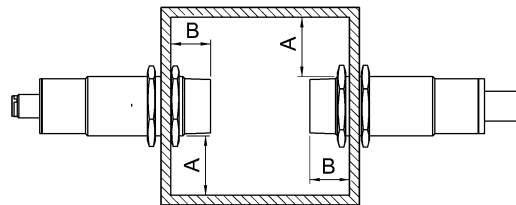

Type	A (mm)	B (mm)
BIC 110-I2A50-M30MI3-SM4A4A	30	20
BIC 210-I2A50-M30MI3-SM4A5A	30	20

Balluff Inductive Coupler

Base BIC 110-I2A50-M30MI3-SM4A4A and Remote BIC 210-I2A50-M30MI3-SM4A5A

5 Installation and Connection

5.3 Angular offset

The permissible angular offset ensures proper function, even in difficult installation conditions:

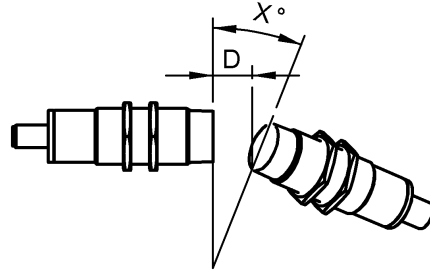

Distance D (mm)	Angle X
1	18°
2	12°
3	10°
4	5°
5	0°

5.4 Connection



Caution!

Device damage due to incorrect voltage supply! Malfunctions may occur if the ripple is too high or if the output voltage is not regulated.

Use only approved, regulated voltage supplies



Caution!

The remote (receiver) may be damaged by voltage spikes if cables that are too long are used! To satisfy the EMC requirements, the cables must not be longer than 20 meters.

5.5 Series connection

Two BIC systems can be connected in series.



Caution!

This cuts the power in half from 500 mA to 250 mA. The cable length between the individual components in each case must not be larger than 20 m. An angular offset can no longer be guaranteed. For that reason, the systems should be positioned accurately. It is not possible to have an air gap larger than 5mm.

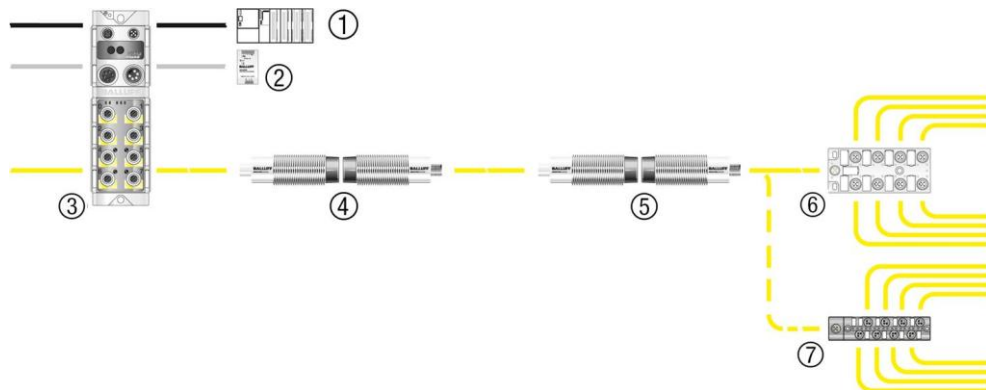

No.	Legend for graphic:	Balluff components
1	Profibus controller	-
2	Balluff power supply	BAE PS-XA-1W-24-050-003
3	Balluff IO-Link master	BNI PBS-502-001-Z001
4+5	BIC IO-Link system	BIC 110-I2A50-M30MI3-SM4A4A BIC 210-I2A50-M30MI3-SM4A5A
6	Balluff sensor hub	BNI IOL-104-000-K006
7	Balluff sensor hub alternative to 6	BNI IOL-104-000-K021

Balluff Inductive Coupler

Base BIC 110-I2A50-M30MI3-SM4A4A and Remote BIC 210-I2A50-M30MI3-SM4A5A

6 Technical data for "Base"

6.1 Dimension

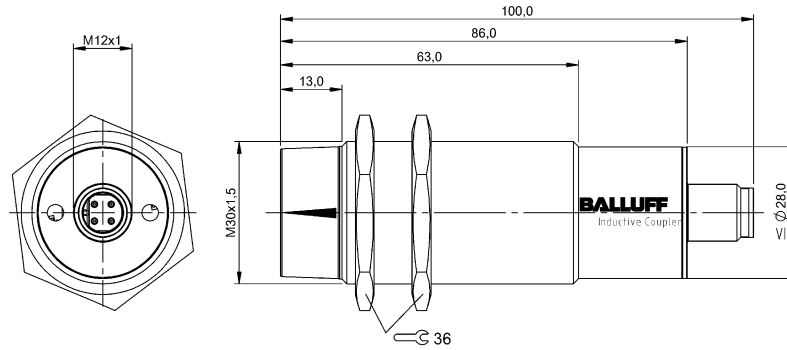

6.2 Mechanical data

Housing material	Brass
Degree of protection as per IEC 60529	IP 67 (only in plugged-in and screwed-down state)
Connection type	M12, A-coded
Dimensions (D x L in mm)	M30 X 100
Weight	Approx. 160 g
Tightening torque	70 Nm

6.3 Operating conditions

Transmission distance	1 to 5 mm
Operating temperature T_a	0 °C to 55 °C
Storage temperature range	-25 °C to 75 °C
EMC EN 61000-4-2/3/4/5/6 EN 55011	Severity 4 ^a /3 ^a /4B/2 ^a /3 ^a Size 1, Cl. A
Vibration	EN 60068-2-6, EN 60068-2-27
Shock	EN 60068-2-29, EN 60068-2-64

6.4 Electrical data

Supply voltage	24 V DC +-10% , acc. to EN 61131-2
Operating current at 24 V	Max. 1 A
Standby current	Max. 100 mA
Overload protection	Yes

6.5 Electrical connection

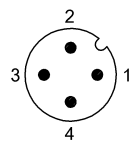

M12, 4-pin, connector

Pin	Signal	Meaning
1	+24 V	Input voltage
2	nc	NC
3	0V	GND,
4	C/Q, IO Link	C/Q, IO Link

Balluff Inductive Coupler

Base BIC 110-I2A50-M30MI3-SM4A4A and Remote BIC 210-I2A50-M30MI3-SM4A5A

7 Technical data for "Remote"

7.1 Dimension

Connector
SM4A5A

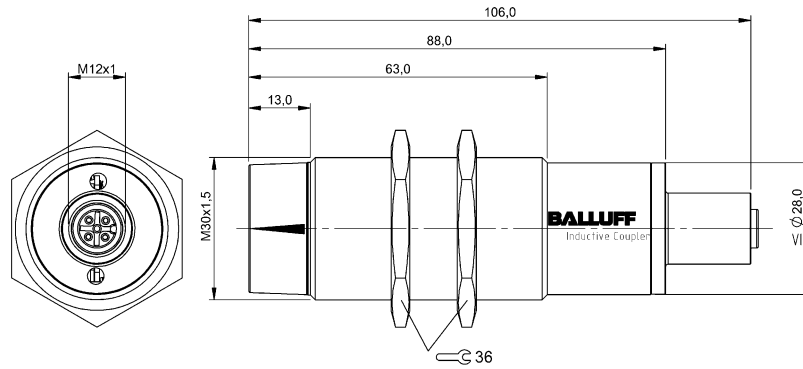

7.2 Mechanical data

Housing material	Brass
Degree of protection as per	IP 67 (only in plugged-in and screwed-down state)
Connection type	M12, A-coded / Cable PUR
Dimensions (D x L in mm)	M30 X 106
Weight	Approx. 160 g
Tightening torque	70 Nm

7.3 Operating conditions

Transmission distance	1 to 5 mm
Operating temperature Ta	0 °C to 55 °C
Storage temperature range	-25 °C to 75 °C
EMC	
Vibration	EN 60068-2-6, EN 60068-2-27
Shock	EN 60068-2-29, EN 60068-2-64

7.4 Electrical data

Supply voltage	24 V DC +-5 %
Output current	500 mA
Short-circuit protected	Yes
Output peak current	Max. 800 mA
Operational readiness	< 100 ms

7.5 Electrical connections M12, 5-pin, socket

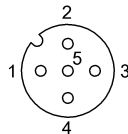

Pin	Signal	Meaning
1	+24 V	Output voltage
2	-	NC
3	0V	GND
4	C/Q, IO Link	C/Q, IO Link
5	nc	NC

Balluff Inductive Coupler

Base BIC 1I0-I2A50-M30MI3-SM4A4A and Remote BIC 2I0-I2A50-M30MI3-SM4A5A

8 IO-Link communication

8.1 Process data

The "Base" transmits 4 bytes of input via the IO-Link. The first ten represent the data of the IO-Link device connected to the "Remote", while the 4th byte contains status information. If an IO-Link device that outputs less than 4 bytes of input data is connected to the "Remote", the remaining, unused bytes are transmitted with "0".

Byte 0							
7	6	5	4	3	2	1	0
PD Byte 0 Bit 7	PD Byte 0 Bit 6	PD Byte 0 Bit 5	PD Byte 0 Bit 4	PD Byte 0 Bit 3	PD Byte 0 Bit 2	PD Byte 0 Bit 1	PD Byte 0 Bit 0

Byte 1*							
7	6	5	4	3	2	1	0
PD Byte 1 Bit 7	PD Byte 1 Bit 6	PD Byte 1 Bit 5	PD Byte 1 Bit 4	PD Byte 1 Bit 3	PD Byte 1 Bit 2	PD Byte 1 Bit 1	PD Byte 1 Bit 0

Byte 2*							
7	6	5	4	3	2	1	0
PD Byte 2 Bit 7	PD Byte 2 Bit 6	PD Byte 2 Bit 5	PD Byte 2 Bit 4	PD Byte 2 Bit 3	PD Byte 2 Bit 2	PD Byte 2 Bit 1	PD Byte 2 Bit 0

Byte 3							
7	6	5	4	3	2	1	0
not used	not used	not used	not used	Status „Supply Remote“	Status „Short Remote“	Status „Inzone“	Status „Com“

* All unused bits and bytes are output with "0".

Explanation of the status bits

Status	Meaning
"Supply remote"	Voltage at the remote is less than 18V
"Short remote"	Short-circuit at the IO-Link interface of the remote
"Inzone"	No remote detected
"Com"	No IO-Link device detected



Note, tip

Process data update time is max. 50ms

Balluff Inductive Coupler

Base BIC 110-I2A50-M30MI3-SM4A4A and Remote BIC 210-I2A50-M30MI3-SM4A5A

8 IO-Link communication

8.2 Parameters

Various base parameters can be accessed via IO-Link. All parameters are read-only, so they involve information, not configuration options. The "Identification data" can contain texts and information about the base. The Direct Parameter page of the IO-Link device connected to the remote is displayed in the "Parameter data".

	DPP	SPDU		Description	Length	Default value
	Index	Index	Sub Index			
Identification data	0 x 07			Vendor ID	2 bytes	0 x 0378
	0 x 08					
	0 x 09			Device ID	3 bytes	0 x 050601
	0 x 0A					
	0 x 0B					
		0 x 10	0	Vendor name	7 bytes	BALLUFF
		0 x 11	0	Vendor text	15 bytes	www.balluff.com
		0 x 12	0	Product name	37 bytes	BIC 110-I2A50-M30MI3-SM4A4A
		0 x 13	0	Product ID	7 bytes	BIC000C
		0 x 14	0	Product text	34 bytes	BIC IOL Base
	0 x 16	0	Hardware revision	3 bytes		
	0 x 17	0	Firmware revision	3 bytes		
Parameterization data		0 x 40 64	0 1 – 16	Direct Parameter page of the IO-Link device on the remote	16 bytes	

8.3 Events

	Event classification			Detailed information			
	Mode	Type	Instance				
Event 1	0 x F3			0 x 5112			
	0 x C0	0 x 30	0 x 03	0 x 5000	0 x 0100	0 x 0010	0 x 0002
	coming	Error	Application	Hardware	Supply	Supply low voltage	U2 = supply + 24 V
Supply voltage is too low							
Event 2	0 x B3			0 x 5112			
	0 x 80	0 x 30	0 x 03	0 x 5000	0 x 0100	0 x 0010	0 x 0002
	going	Error	Application	Hardware	Supply	Supply low voltage	U2 = supply + 24 V
Supply voltage is OK again							

Balluff Inductive Coupler



Base BIC 1I0-I2A50-M30MI3-SM4A4A and Remote BIC 2I0-I2A50-M30MI3-SM4A5A

9 Accessories





9.1 Connectors

Description	Description	Remarks
PUR for base, open cable end	BCC M415-0000-1A-003-PX0434-xxx	XXX -> cable length
PUR for base and remote as jumper	BCC M415-M414-3A-304-PX0434-xxx	XXX -> cable length
PUR for remote, open cable end	BCC M415-0000-1A-003-PX0434-xxx	XXX -> cable length

9.2 Installation accessories

Description	Description	Fig.
	BES 30.0-BS-1	
	BES 30-HW-1	

9.3 Active components

Description	Description	Fig.
Profibus connection for base	BNI PBS-507-001-Z011	
Profibus connection for base	BNI PBS-502-001-Z001	
Profibus connection for base	BNI PBS-504-001-K008	
Profinet connection for base	BNI PNT-502-105-Z015	

Balluff Inductive Coupler
Base BIC 1I0-I2A50-M30MI3-SM4A4A and
Remote BIC 2I0-I2A50-M30MI3-SM4A5A

10 Type code

10.1 Type Code

BIC 1I0-I2A50-M30MI3-XXXXXX_002-M45A

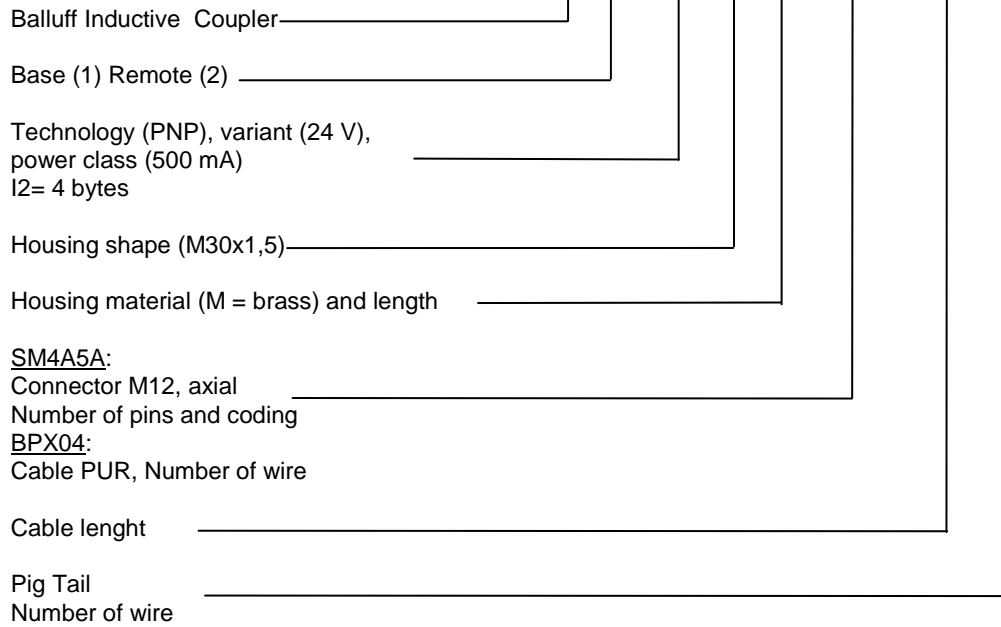

10.2 Order code

Description	Order code
BIC 1I0-I2A50-M30MI3-SM4A4A	BIC000C
BIC 2I0-I2A50-M30MI3-SM4A5A	BIC000E



www.balluff.com

Balluff GmbH
Schurwaldstrasse 9
73765 Neuhausen a.d.F.
Germany
Tel. +49 7158 173-0
Fax +49 7158 5010
balluff@balluff.de
www.balluff.com

888373 E • Edition L14 • Replaces Edition C12 • Subject to modification