

BNI EIP-104-105-R015 **BNI EIP-302-105-R015** **EtherNet/IP IP67 Modules** **User's Guide**

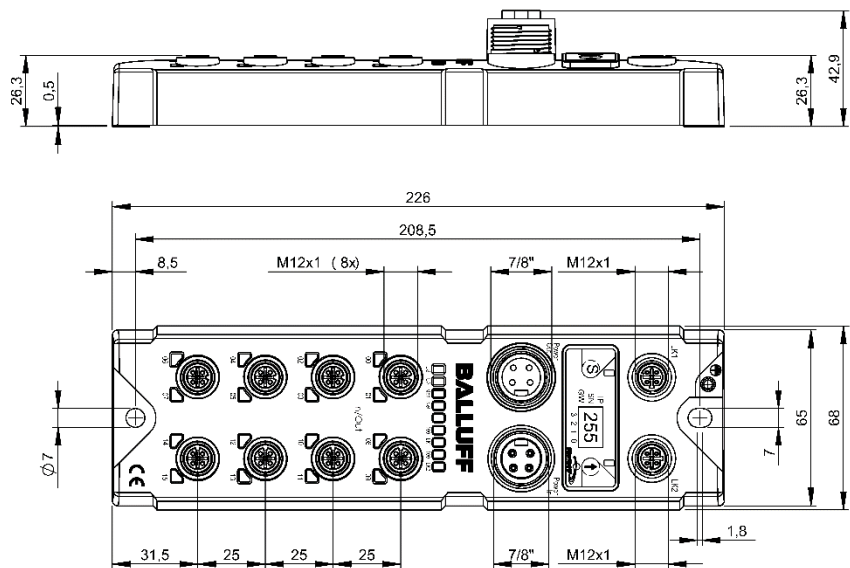







Content

1	Notes	3
1.1.	Structure of the guide	3
1.2.	Typographical Conventions	3
	Enumerations	3
	Actions	3
	Syntax	3
	Cross-references	3
1.3.	Symbols	3
1.4.	Abbreviations	3
1.5.	Deviating views	3
2	Safety	4
2.1.	Intended use	4
2.2.	Installation and startup	4
2.3.	General safety notes	4
2.4.	Resistance to aggressive substances	4
	Hazardous voltage	4
3	Getting Started	5
3.1.	Module overview	5
3.2.	Mechanical connection	6
3.3.	Electrical connection	6
	Power Supply	6
	Grounding	6
	Ethernet IP Interface	6
	I/O-Port	7
4	Technical data	8
4.1.	Dimensions	8
4.2.	Mechanical data	8
4.3.	Operating conditions	8
4.4.	Electrical data	8
4.5.	Ethernet	9
4.6.	Function indicators	9
	Module status	9
	Port	9
5	Integration	10
5.1.	Integration into a Rockwell RS Logix 5000	10
6	Configuration via Explicit Messages	14
	QuickConnect	14
	Rockwell Automation Products that are Compatible with QuickConnect	15
	Example with Rockwell Components	16
	PLC Program	17
	Fault State	20
	Enable/Disable Fault State	20
	Fault State Action	20
7	Process Data	21
7.1.	Data Configuration	21
	BNI EIP-302-105-R015	21
7.2.	Process Data Inputs	21
	BNI EIP-302-105-R015	21
7.3.	Process Data Output	21
	BNI EIP-302-105-R015	21
7.4.	Data Configuration	22

Balluff Network Interface EtherNet/IP

BNI EIP-104-105-R015	22
7.5. Process Data Inputs BNI EIP-104-105-R015	22
7.6. Process Data Output BNI EIP-104-105-R015	22
8 Display	23
8.1. General	23
8.2. Address Specifications	23
8.3. Controls and visualization	23
8.4. Display information	23
8.5. Design and Symbols	24
8.6. Startup	24
8.7. Main Menue	24
8.8. IP Setup	25
8.9. Network Config	25
8.10. Edit mode	26
8.11. Module information	27
8.12. General Informations	27
9 Webserver	28
9.1. General Information	28
9.2. Navigation / Info	29
9.3. Login/Logout	30
9.4. "Home" dialog	31
9.5. "Config" dialog	33
9.6. "Log" dialog	35
10 Appendix	36
10.1. Included material	36
10.2. Order code	36
10.3. Order Information	36

1.1. Structure of the guide	The guide is organized so that the chapters build on one another. Chapter 2: Basic safety information. Chapter 3: The main steps for installing the device.												
1.2. Typographical Conventions	The following typographical conventions are used in this Guide.												
Enumerations	Enumerations are shown in list form with bullet points. <ul style="list-style-type: none"> • Entry 1, • Entry 2. 												
Actions	Action instructions are indicated by a preceding triangle. The result of an action is indicated by an arrow. <ul style="list-style-type: none"> ➤ Action instruction 1. ↪ Action result. ➤ Action instruction 2. Procedures can also be shown as numbers in brackets. <ul style="list-style-type: none"> (1) Step no. 1 (2) Step no. 2 												
Syntax	Numbers: Decimal numbers are shown without additional indicators (e.g. 123), Hexadecimal numbers are shown with the additional indicator hex (e.g. 00 _{hex}) or with the prefix "0x" (e.g. 0x00)												
Cross-references	Cross references indicate where additional information on the topic can be found.												
1.3. Symbols	<hr/> <table border="0" style="width: 100%;"> <tr> <td style="width: 20px; vertical-align: middle;"></td> <td>Note This symbol indicates general notes.</td> </tr> </table> <hr/> <table border="0" style="width: 100%;"> <tr> <td style="width: 20px; vertical-align: middle;"></td> <td>Attention! This symbol indicates a security notice which must be observed.</td> </tr> </table> <hr/>		Note This symbol indicates general notes.		Attention! This symbol indicates a security notice which must be observed.								
	Note This symbol indicates general notes.												
	Attention! This symbol indicates a security notice which must be observed.												
1.4. Abbreviations	<table border="0" style="width: 100%;"> <tr> <td style="width: 40px;">BNI</td> <td>Balluff Network Interface</td> </tr> <tr> <td>I</td> <td>Standard input port</td> </tr> <tr> <td>EIP</td> <td>EtherNet/IP™</td> </tr> <tr> <td>EMC</td> <td>Electromagnetic Compatibility</td> </tr> <tr> <td>FE</td> <td>Function ground</td> </tr> <tr> <td>O</td> <td>Standard output port</td> </tr> </table>	BNI	Balluff Network Interface	I	Standard input port	EIP	EtherNet/IP™	EMC	Electromagnetic Compatibility	FE	Function ground	O	Standard output port
BNI	Balluff Network Interface												
I	Standard input port												
EIP	EtherNet/IP™												
EMC	Electromagnetic Compatibility												
FE	Function ground												
O	Standard output port												
1.5. Deviating views	Product views and illustrations in this manual may differ from the actual product. They are intended only as illustrative material.												

2 Safety

2.1. Intended use This guide describes The BNI EIP-... serves as a decentralized input and output module for connecting to an EtherNet/IP™ network.

2.2. Installation and startup

 **Attention!**
 Installation and startup are to be performed only by trained specialists. Qualified personnel are persons who are familiar with the installation and operation of the product, and who fulfills the qualifications required for this activity. Any damage resulting from unauthorized manipulation or improper use voids the manufacturer's guarantee and warranty. The Operator is responsible for ensuring that applicable of safety and accident prevention regulations are complied with.

2.3. General safety notes

Commissioning and inspection
 Before commissioning, carefully read the User's Guide.
 The system must not be used in applications in which the safety of persons depends on the function of the device.

Intended use
 Warranty and liability claims against the manufacturer shall be rendered void by damage from:

- Unauthorized tampering
- Improper use
- Use, installation or handling contrary to the instructions provided in this User's Guide.

Obligations of the owner/operator
 The device is a piece of equipment in accordance with EMC Class A. This device can produce RF noise. The owner/operator must take appropriate precautionary measures against this for its use. The device may be used only with a power supply approved for this. Only approved cables may be connected.

Malfunctions
 In the event of defects and device malfunctions that cannot be rectified, the device must be taken out of operation and protected against unauthorized use.
 Intended use is ensured only when the housing is fully installed.

2.4. Resistance to aggressive substances

 **Attention!**
 The BNI modules generally have a good chemical and oil resistance. When used in aggressive media (eg chemicals, oils, lubricants and coolants each in high concentration (ie, low water content)) must be checked prior application-related material compatibility. In the event of failure or damage to the BNI modules due to such aggressive media are no claims for defects.

Hazardous voltage

 **Attention!**
 Disconnect all power before servicing equipment.

 **Note**
 In the interest of product improvement, the Balluff GmbH reserves the right to change the specifications of the product and the contents of this manual at any time without notice.

3.1. Module overview

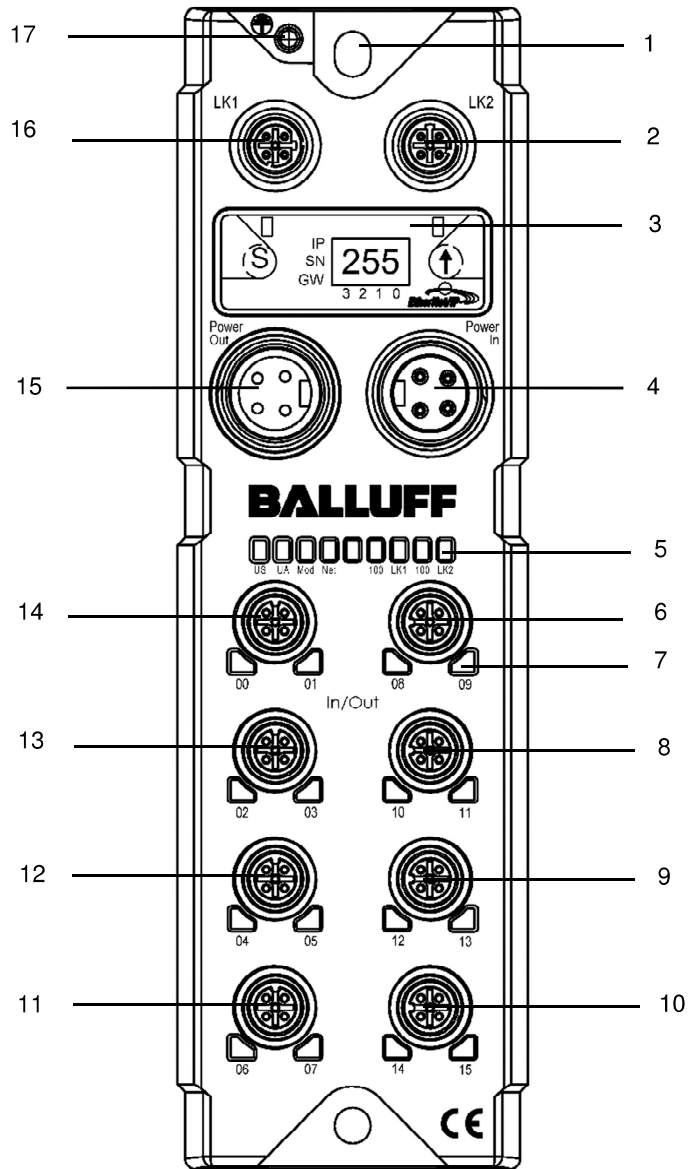

Overview BNI EIP-xxx-105-R015

- | | | | |
|---|------------------------------------|----|----------------------|
| 1 | Mounting hole | 10 | Port 14 / 15 |
| 2 | EtherNet/IP™ port 2 | 11 | Port 06 / 07 |
| 3 | Display | 12 | Port 04 / 05 |
| 4 | Power IN | 13 | Port 02 / 03 |
| 5 | Status-LED: Communication / Module | 14 | Port 00 / 01 |
| 6 | Port 08 / 09 | 15 | Power OUT |
| 7 | Pin/Port LED : Signal status | 16 | EtherNet/IP™ port 1 |
| 8 | Port 10 / 11 | 17 | Grounding connection |
| 9 | Port 12 / 13 | | |

3 Getting Started

3.2. Mechanical connection

The module is attached using 2 M6 screws and 2 washers.
Isolation pad as accessory available

3.3. Electrical connection

Power Supply

<p>IN 7/8" male</p> <p>OUT 7/8" female</p>	Pin	Function	Description
	1	+24 V	Actuator power supply
	2	+24 V	Module / sensor power supply
	3	0 V	GND module / sensor and actuator supply
4			

Note



Provide sensor/bus power and actuator power from separate power sources if possible.

Total current <9A. The total current of all modules may not exceed 9A even when daisy chaining the actuator supply.

Grounding

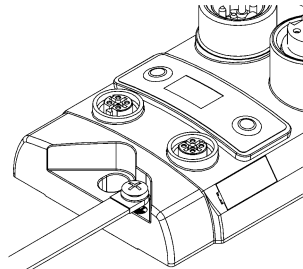

Note

The FE connection from the housing to the machine must be low-impedance and kept as short as possible.

Ethernet IP Interface

M12, D-coded, female

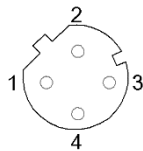

Pin	Function	
1	Tx+	Transmit Data +
2	Rx+	Receive Data +
3	Tx-	Transmit Data -
4	Rx-	Receive Data -

I/O-Port

M12, A-coded, female

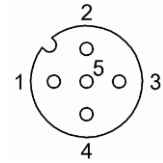

Pin	Function	
	104	302
1	+24V, 200mA	+24V, 200mA
2	Input	Input/Output 2A
3	GND	GND
4	Input	Input/Output 2A
5	FE	FE

**Note**

For the digital sensor inputs follow the input guideline per EN61131-2, type 2.

**Note**

Each output serves a maximum current of 2 amperes. Total current of the module has to be lower than 9 amperes.

**Note**

Unused I/O port socket must be fitted with cover caps to ensure IP67 protection rating.

4 Technical data

4.1. Dimensions

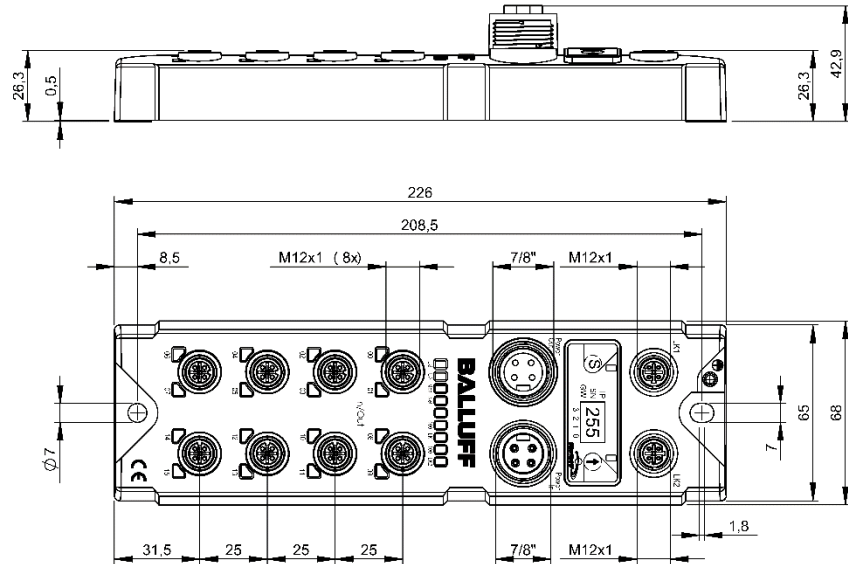

4.2. Mechanical data

Housing material	Plastic housing, resistant (Fortron 6165 A6 black)
Enclosure rating per IEC 60529	IP 67 (only when plugged-in and threaded-in)
Supply voltage	7/8" 4-pin male / female
Input ports / Output ports	M12, A-coded (8 x female)
Dimensions (W x H x D in mm)	68 x 226 x 42.9
Mounting type	2-hole screw mount
Ground strap attachment	M4
Weight	Approx. 670 gr.

4.3. Operating conditions

Operating temperature T _a	-5 °C ... 70 °C
Storage temperature	-25 C ... 70 °C

4.4. Electrical data

Supply voltage	18...30.2 V DC, per EN 61131-2
Ripple	<1%
Input current at 24 V	130 mA

4.5. Ethernet

Ethernet IP port	1 x 10Base-/100Base-Tx
Connection for Ethernet IP port	M12, D-coded
Cable types per IEEE 802.3	Shielded twisted pair min. STP CAT 5/ STP CAT 5e
Data transmission rate	10/100 Mbit/s
Max. cable length	100 m
Flow control	Half Duplex/Full Duplex (IEEE 802.3x-Pause)

4.6. Function indicators

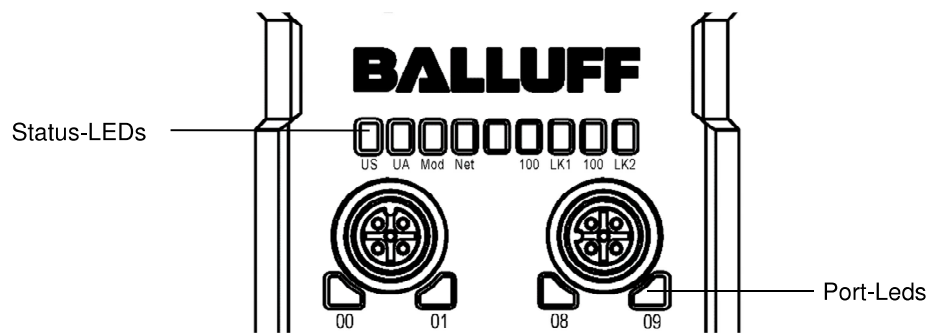

Module status

LED	Status	Function
UA	green	Output power OK
	red	Low Output power (< 18V)
US	green	Input power OK
	red	Low Input power (<18V)
Mod	green flashing	Wrong or no configuration on module
	green	Modul operating
	red flashing	Fixed busclock is not possible
	red-green flashing	Initial sequence
Net	off	Module got no IP address
	green flashing	Module got IP, but no connection could be established
	green	Connection established
	red flashing	Connection timeout
100	red-green flashing	Initial sequence
	off	Bus clock: 10 Mbit/s
LNK	yellow	Bus clock: 100 Mbit/s
	green	Data transfer

Port

Each Port has two two-colour LEDs to indicate the I/O-States.

	Status	Function	Description
I/O Port	off	I/O-State	State of the Input or Output Pin is 0
	yellow	I/O-State	State of the Input or Output Pin is 1
	red flashing	Short-circuit	Short-circuit between Pin 1 and 3
	red	Short-circuit	Short-circuit to dedicated Pin

5 Integration

5.1. Integration into a Rockwell RS Logix 5000

Here you see an example of how the module can be integrated into a Rockwell RS Logix 5000:

First go offline

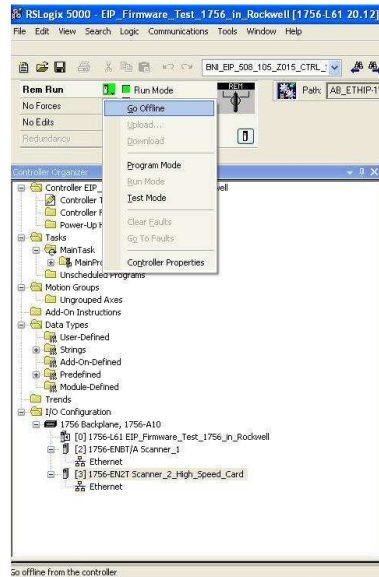

Right-click Ethernet (on the correct scanner card)
Select a new module

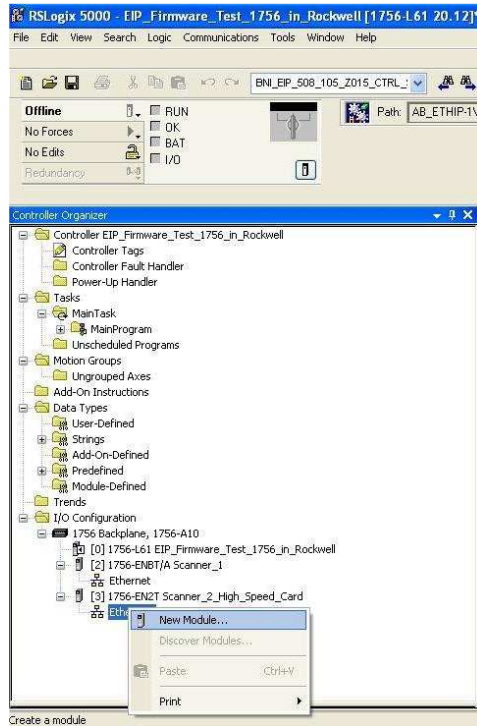

Then select the general Ethernet module as the ETHERNET module in the communication path

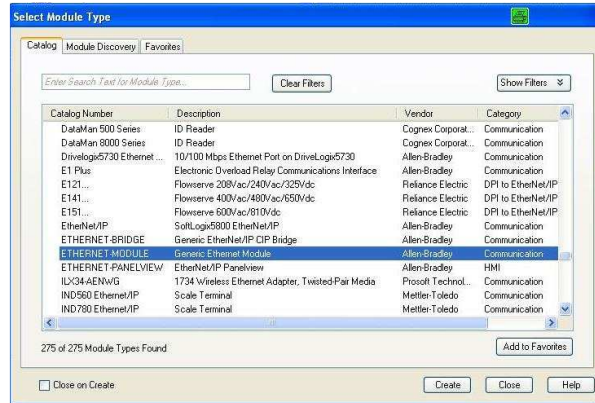

Now enter a user-defined tag name to select the general format Data-SINT, to enter the IP address of the module and to enter the correct connection parameters.

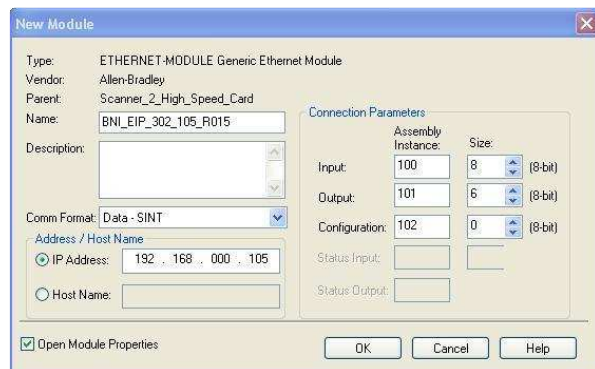

5 Integration

The new module and corresponding controller tags are generated automatically.

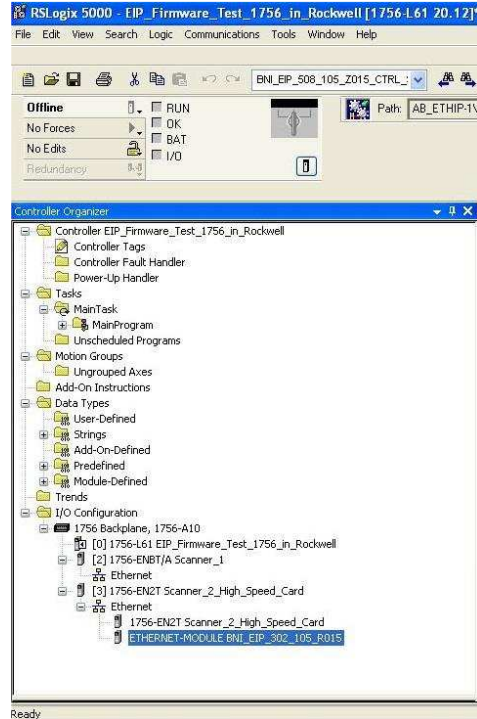

Then download the configuration

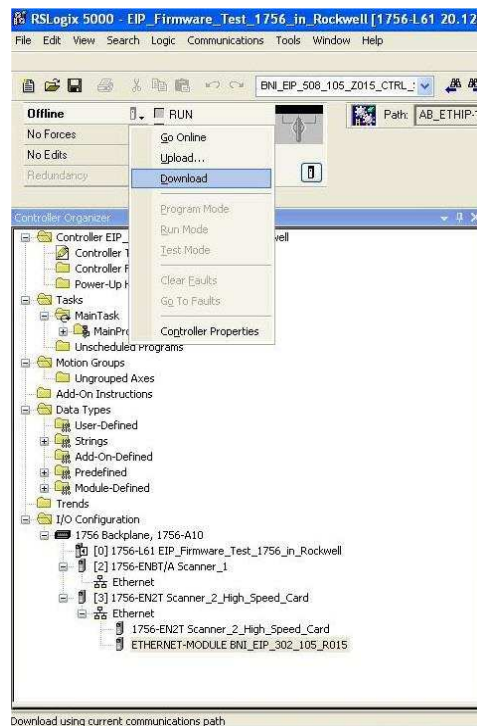

When the download is done, you can observe and control the tags using the Controller Tags option. Make sure you select the correct tag name, which you configured beforehand. The input, output and configuration data for this is described on the following pages. You can use these tags for the programming, too.

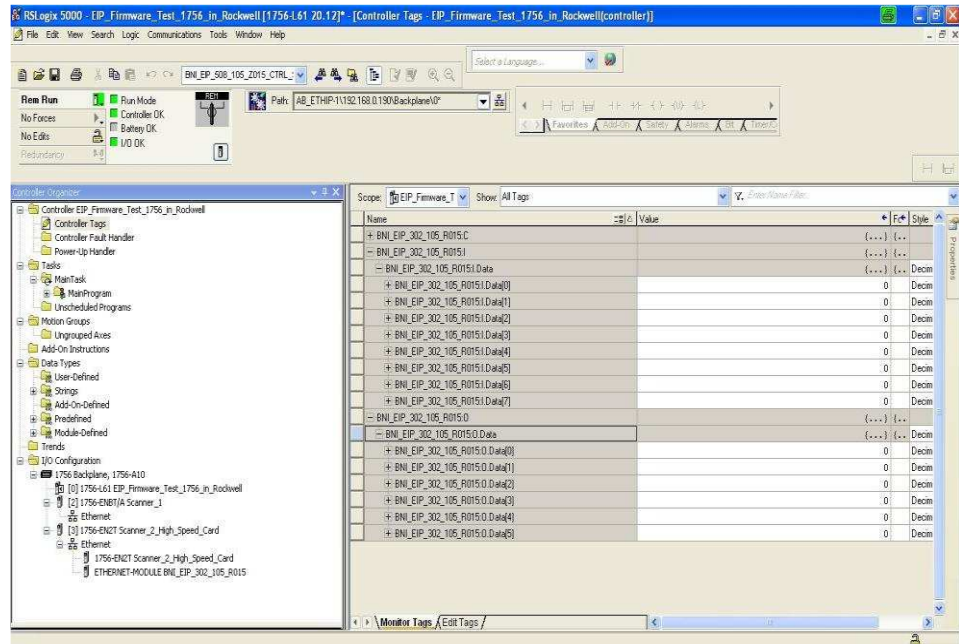

6 Configuration via Explicit Messages

QuickConnect The QuickConnect function makes it faster to boot up and integrate the BNI EIP-302-105-X015 and BNI EIP-104-105-X015 modules.

Enabling QuickConnect automatically takes over all necessary port properties on the module:

- Static IP address
- Ports at 100 Mbps full-duplex
- Auto-negotiation disabled
- Auto MDI-X disabled
- Prepared for linear topology

You can configure QuickConnect via the following class instance attribute of the explicit messages:

Class	Instance	Attribute	Value
245 (0xF5)	1 (0x01)	12 (0x0C)	0: disabled (default) 1: enabled



Note

For QuickConnect to be enabled, ACD (Address Conflict Detection) must also be enabled. This is switched on by default.

The ACD can be reviewed and changed using the following class instance attributes of the explicit messages:

Class	Instance	Attribute	Value
245 (0xF5)	1 (0x01)	10 (0x0A)	0: disabled 1: enabled (default)

Overview of the QuickConnect classes and connection time:

BNI EIP-302-105-x015 HW 4 SW 2.6:
QuickConnect Class B, connection time 1 second

BNI EIP-104-105-x015 HW 4 SW 2.9:
QuickConnect is not supported.

BNI EIP-302-105-x015 HW 6 SW 3.6:
QuickConnect Class A, connection time 350 milliseconds

BNI EIP-104-105-x015 HW 6 SW 3.6:
QuickConnect Class A, connection time 350 milliseconds

Rockwell
Automation
Products that
are Compatible
with
QuickConnect

Component	Supported Rockwell Automation Products
Controller	ControlLogix® controllers: <ul style="list-style-type: none"> • 1756-L6x • 1756-L7x GuardLogix controllers: <ul style="list-style-type: none"> • 1756-L6xS • 1756-L7xS All controllers require firmware revision 20.001 or later.
EtherNet/IP managed switch on the controller side	Stratix 6000 switches: <ul style="list-style-type: none"> • 1783-EMS04T • 1783-EMS08T Stratix 8000 switches: <ul style="list-style-type: none"> • 1783-MS06T or 1783-MS10T • 1783-RMS06T or 1783-RMS10T • 1783-MX08T or 1783-MX08F
EtherNet/IP communication modules	ControlLogix communication modules: <ul style="list-style-type: none"> • 1756-EN2T with firmware revision 4.003 • 1756-ENBT with firmware revision 6.002
Application logic that uses generic CIP Messages to inhibit and uninhibit I/O modules	Studio 5000 Logix Designer application, version 21.00.00 or later or RSLogix 5000 software, version 20.01.02

Source:
Allen-Bradley Ethernet/IP QuickConnect Application Technique
Page 13

Example with
Rockwell
Components

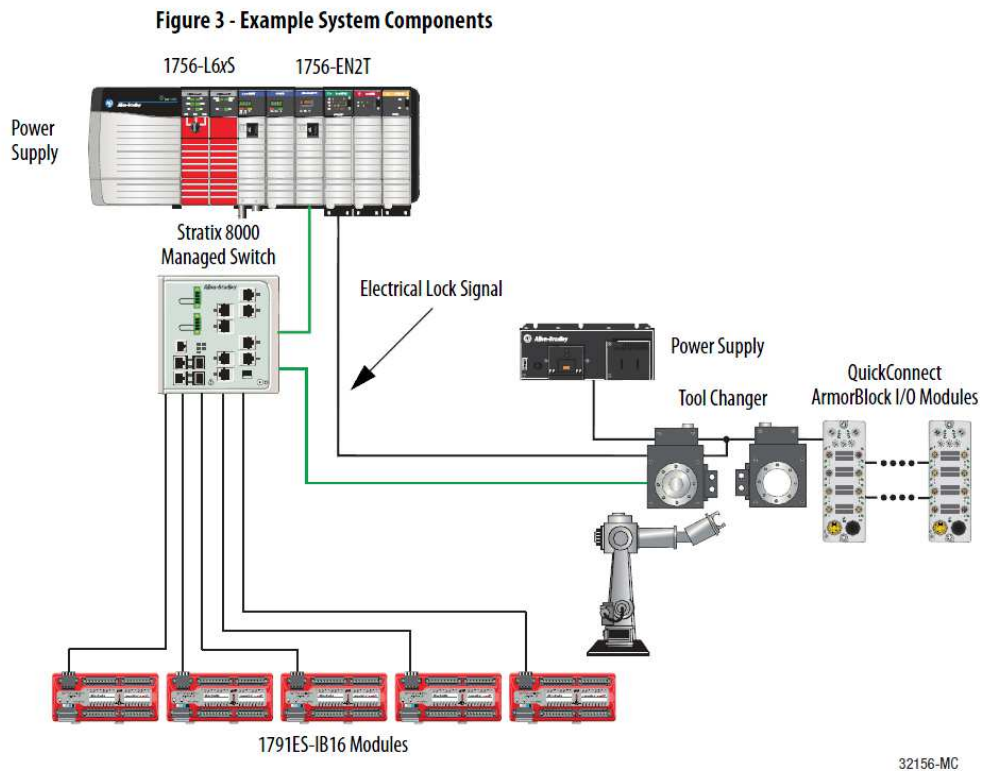

Source:
Allen-Bradley Ethernet/IP QuickConnect Application Technique, Page 12

Please also note the following:

- Direct connection between PLC and QuickConnect slave with crossover cable
- Slave-to-slave connection using patch cable
- For setting up the topology, only the linear topology with a maximum of 20 modules on the tool side is permitted.
- If needed, only one managed switch may be used between the PLC and Ethernet/IP slave.
- To trigger the QuickConnect sequence, an electrical lock signal is required that reads in the supply voltage of the QuickConnect slaves via the controller.

PLC Program

Add Application Logic

Add ladder logic to inhibit and uninhibit QuickConnect I/O modules:

- Run this logic in a periodic task with a recommended 10 ms update rate.
- The logic examples shown configure two ArmorBlock I/O modules. Modify the code as needed to configure as many as 20 ArmorBlock I/O modules.

IMPORTANT A connection time of 500 ms with 20 QuickConnect modules is supported with only a ControlLogix 1756-L7x controller and 1756-EN2T communication module. For average connection times per number of modules, see [Average Timing with Rockwell Automation Products on page 50](#).

Inhibit and Power Down

Add this logic to inhibit and power down the QuickConnect modules.

1. Rung 0: Inhibit the modules.

Before making a tool change, you must uninhibit the QuickConnect ArmorBlock I/O modules mounted to the tool before powering down. Use a GSV (Mode) instruction to monitor the present state of the modules and one SSV (Mode) instruction per module to inhibit the modules.

The input condition to start the inhibit process must come from an external input. For example, as the robot is traveling back to change out the tool, this input condition must be enabled. By the time the tool is being changed, the modules are inhibited and can proceed to powering down the tool and modules.

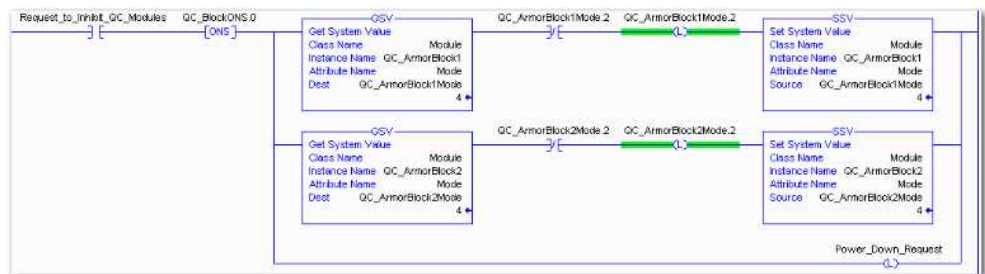

Source: Allen-Bradley Ethernet/IP QuickConnect Application Technique, Page 29

6 Configuration via Explicit Messages

2. Rung 1: Verify the modules are inhibited.

After the modules have been inhibited, verify that the modules have indeed been inhibited. Use one GSV (Entry Status) instruction per module. When the Entry Status value equals a decimal value of 24576, the module can be disconnected from the robotic arm and powered down.

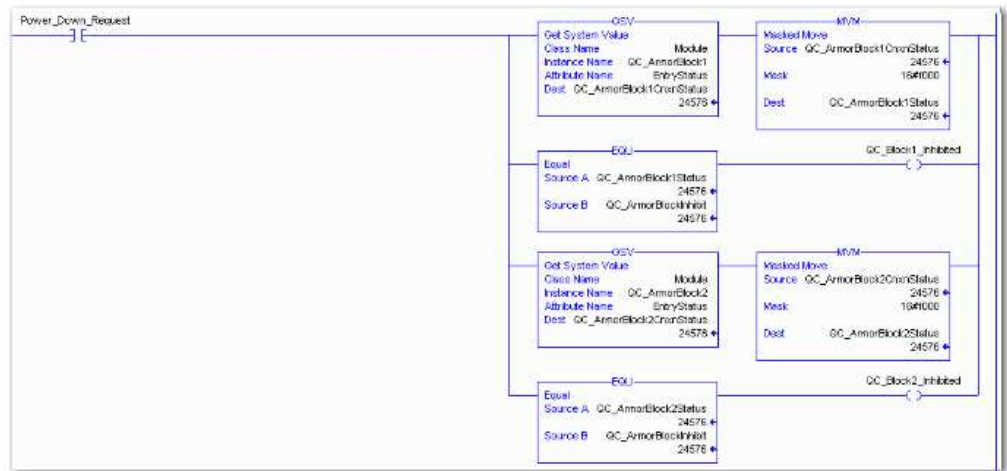

3. Rung 2: Power down the modules.

This rung verifies that all the modules have been inhibited and powered down. The tool and modules can be physically disconnected from the robotic arm.



Source:

Allen-Bradley Ethernet/IP QuickConnect Application Technique, Page 30

Uninhibit and Power Up

Add this logic to uninhibit and power up the QuickConnect I/O modules.

1. Rung 3: Power up the modules.

Once the tool and module is connected, an external input module sends an electrical lock input signal. On receipt of the signal, start a timer to keep track of how long the tool and modules have been connected.

Every QuickConnect ArmorBlock I/O module has a delay time embedded in its electronic data sheet (EDS) file. This delay time is the amount of time the module takes to power up. The module takes about 300 ms to fully power up before establishing a connection to the controller.



2. Rung 4: Uninhibit the modules.

When the Timer, Acc is greater then or equal to the module delay time (300 ms), use an SSV (Mode) instruction to uninhibit the module. Use a GSV (Mode) instruction to verify the mode of the module at powerup.

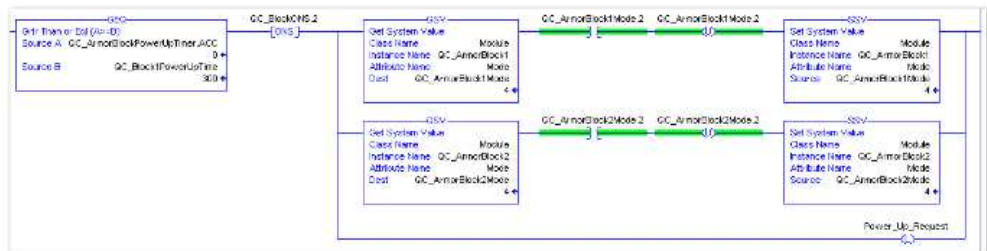

Source: Allen-Bradley Ethernet/IP QuickConnect Application Technique, Page 31

6 Configuration via Explicit Messages

3. (Optional) Rung 5: Verify the modules are uninhibited.

After the modules have been uninhibited, verify that the modules have indeed been uninhibited. Use one GSV (Entry Status) instruction per module. When the Entry Status value equals a decimal value of 16384, the module has been uninhibited.

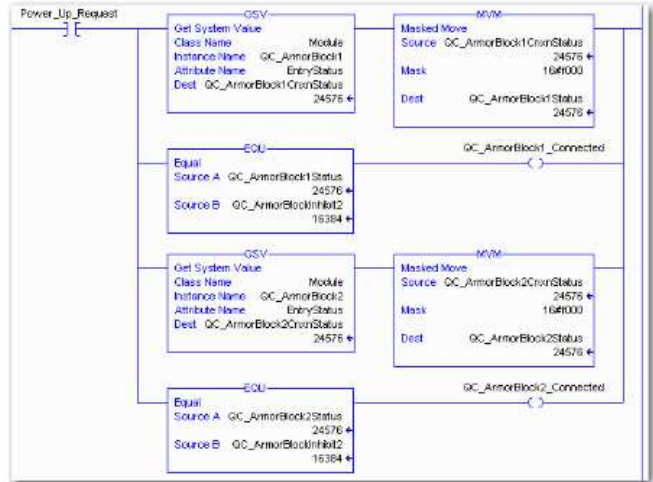

Source:
Allen-Bradley Ethernet/IP QuickConnect Application Technique, Page 32

Fault State

A safe state that the port is to take on in the case of a loss of bus communication can be predefined for each output on the port pins.

The fault state settings can be configured using the following class instance attributes of the explicit messages.

Enable/Disable Fault State

Class	Instance	Attribute	Value
9 (0x09)	1 – 16 (corresponds to outputs 0-15)	6	0: Fault state disabled 1: Fault state enabled

Fault State Action

Class	Instance	Attribute	Value
9 (0x09)	1 – 16 (corresponds to outputs 0-15)	5	0: Output on 1: Hold last state

Note



The fault state settings are stored only temporarily in the module. They are deleted after a power reset.

To ensure a long-term fault state configuration, the configuration has to be programmed via the PLC so that the settings are transferred to the module again when the system is restarted.

7 Process Data

7.1. Data Configuration BNI EIP-302-105-R015

Please enter the following values to your Control System. They describe the datasizes for input, output and config data.

	Instance ID	Data length
INPUT	100	8
OUTPUT	101	6

7.2. Process Data Inputs BNI EIP-302-105-R015

There are 8 bytes of Input data. Have a look at the tables below to see the mapping of the process data inputs.

Byte	Bit								Description
	7	6	5	4	3	2	1	0	
0	I32	I34	I22	I24	I12	I14	I02	I04	Input data I04 → Input on port 0 pin 4
1	I72	I74	I62	I64	I52	I54	I42	I44	
2	S3		S2		S1		S0		Short circuit status Short circuit between Pin 1 and 3 on stated port
3	S7		S6		S5		S4		
4	O22	O34	O22	O24	O12	O14	O02	O04	Overload status O04 → Overload on port 0 pin 4 Only if port is configured as output
5	O72	O74	O62	O64	O52	O54	O42	O44	
6	0	0	0	0	0	0	PS	PA	Power status PS: Sensor power PA: actor power
7	0	0	0	0	0	0	0	0	Reserved

7.3. Process Data Output BNI EIP-302-105-R015

There are 6 bytes of output data. Have a look at the tables below to see the mapping of the process data outputs.

Byte	Bit								Description
	7	6	5	4	3	2	1	0	
0	O32	O34	O22	O24	O12	O14	O02	O04	Output data O04 → Output on port 0 pin 4
1	O72	O74	O62	O64	O52	O54	O42	O44	
2	R32	R34	R22	R24	R12	R14	R02	R04	Restart Restart output here after a detected short-circuit
3	R72	R74	R62	R64	R52	R54	R42	R44	
4	0	0	0	0	0	0	0	0	Reserved
5	0	0	0	0	0	DL	GO	RO	Display Control DL: Display lock / PLC lock GO: Green LED on Display on RO: Red LED on Display on

7 Process Data

7.4. Data Configuration
BNI EIP-104-105-R015

Please enter the following values to your Control System. They describe the datasizes for input, output and config data.

	Instance ID	Data length
INPUT	100	6
OUTPUT	101	2

7.5. Process Data Inputs
BNI EIP-104-105-R015

There are 6 bytes of Input data. Have a look at the tables below to see the mapping of the process data inputs.

Byte	Bit								Description
	7	6	5	4	3	2	1	0	
0	I32	I34	I22	I24	I12	I14	I02	I04	Input data I04 → Input on port 0 pin 4
1	I72	I74	I62	I64	I52	I54	I42	I44	
2	S3		S2		S1		S0		Short circuit status Short circuit between Pin 1 and 3 on stated port
3	S7		S6		S5		S4		
4	0	0	0	0	0	0	PS	PA	Power status PS: Sensor power PA: actor power
5	0	0	0	0	0	0	0	0	Reserved

7.6. Process Data Output
BNI EIP-104-105-R015

There are 2 bytes of output data. Have a look at the tables below to see the mapping of the process data outputs.

Byte	Bit								Description
	7	6	5	4	3	2	1	0	
0	0	0	0	0	0	0	0	0	Reserved
1	0	0	0	0	0	DL	GO	RO	Display Control DL: Display lock / PLC lock GO: Green LED on Display on RO: Red LED on Display on

8.1. General

With the implemented display, the address is set directly on the BNI EIP... devices.
The following address types are implemented:

- IP address
- Subnet mask
- Gateway address.

Each address type consists of 4 octets.

Additional the display shows information about the hard- and firmwarerevision.

There is a lock function for the display which can be activated out of the control system. If the lock is set editing isn't possible anymore.

8.2. Address Specifications

IP Address: 192.168.1.1
Subnetmask: 255.255.255.0
Gatewayaddress: 192.168.1.1

8.3. Controls and visualization

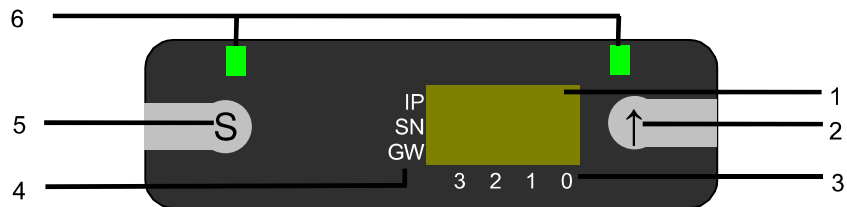

- | | |
|-----------------|-----------------------|
| 1 Display | 4 Address type cursor |
| 2 Arrow-Key | 5 „Set“-Key |
| 3 Octett-Cursor | 6 LED |

8.4. Display information

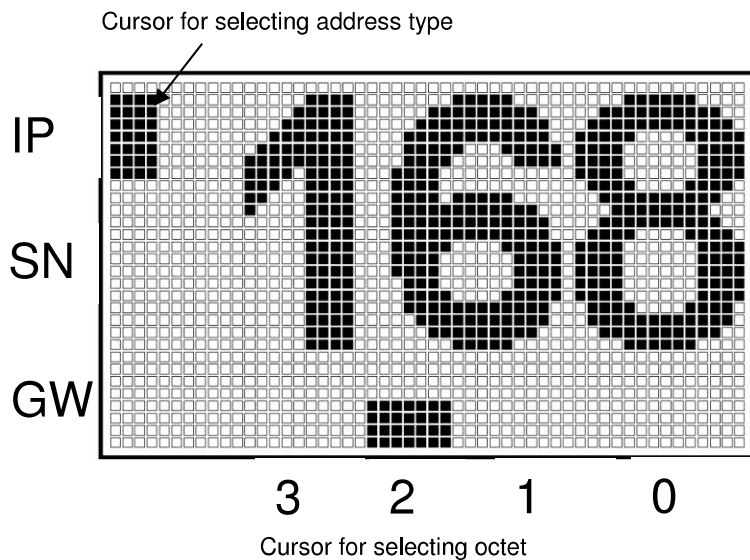

IP: IP address
SN: Subnet address
GW: Gateway address

3: first octet
2: second octet
1: third octet
0: fourth octet

8 Display

8.5. Design and Symbols

There are some symbols used in the following flow-charts to describe the display-functionality:

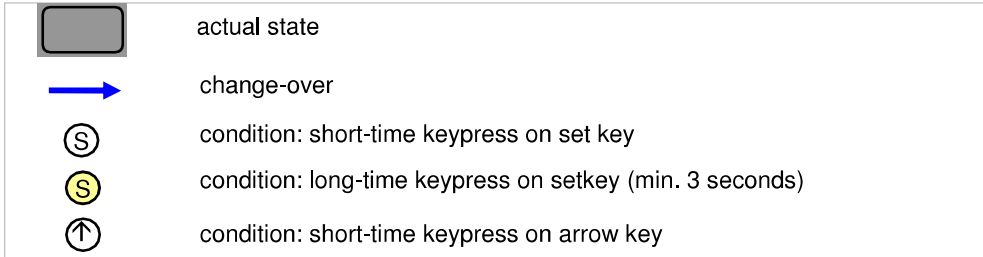

8.6. Startup

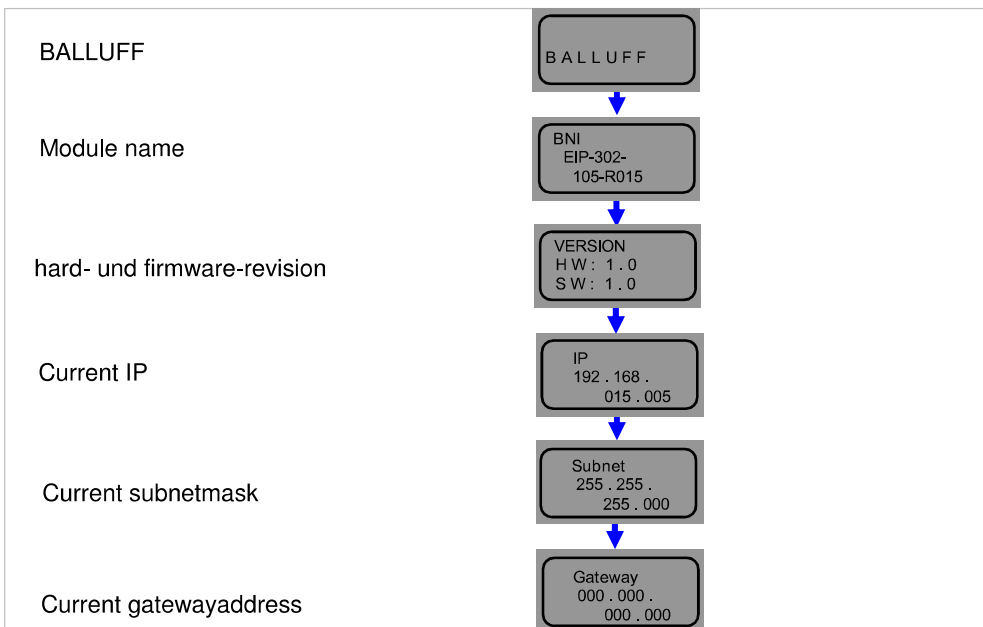

8.7. Main Menu

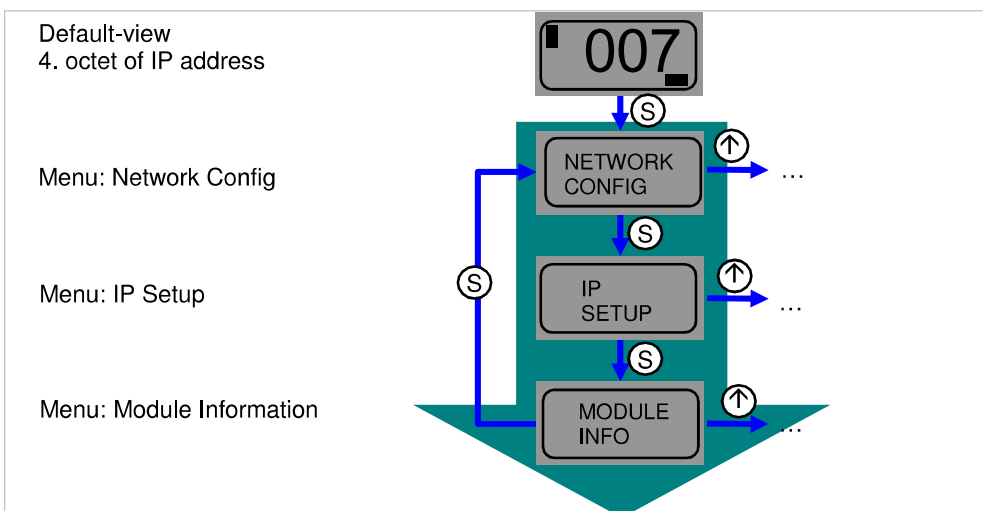

- Scrolling in main menu with short-time keypress on set-key
- Step in menu with short-time keypress on arrow-key

8.8. IP Setup

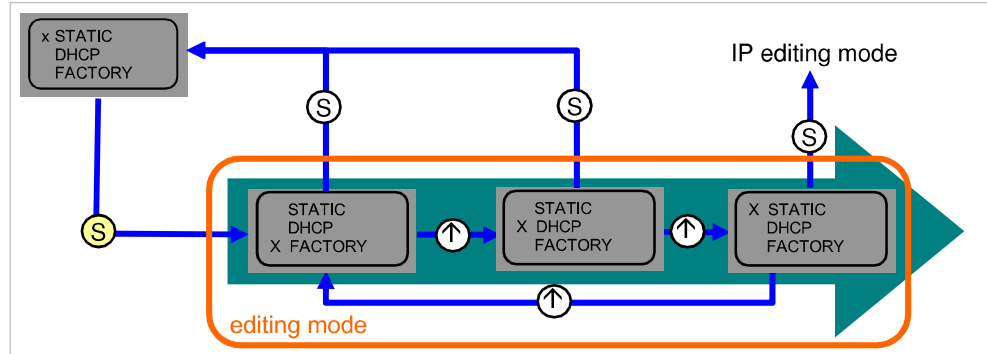

- Long-time keypress on set key starts editing mode.
- Configuration of the favored value by short-time keypress on arrow-key

8.9. Network Config

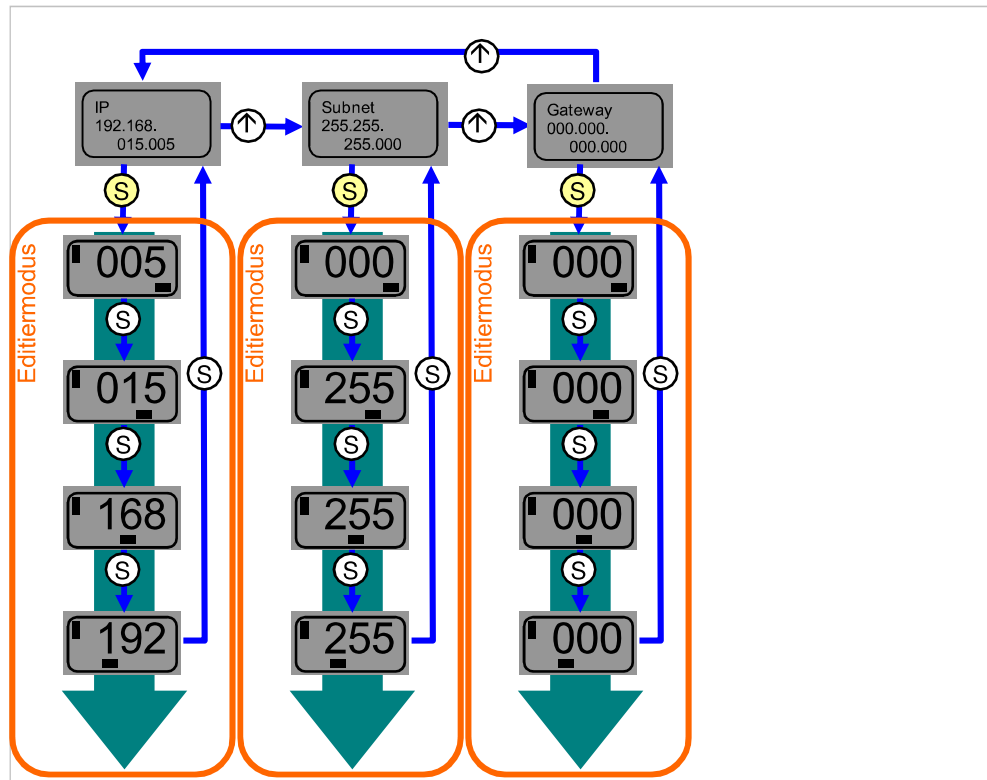

- Long-time keypress on set key starts editing mode.
- Configuration of the favored value by short-time keypress on arrow-key
- Long-time keypress on arrow key uses fast program mode
- Shorttime keypress on set key saves entered value and scrolls to the next octet. The 4.octet is the start of editing
- The whole entered address gets saved by short keypress on set value when editing first octet. The entered value can immediately seen on the ip overview screen.
- Manual changes to IP, subnet or gateway results in automatic change to “static” in IP Setup.

8.10. Edit mode

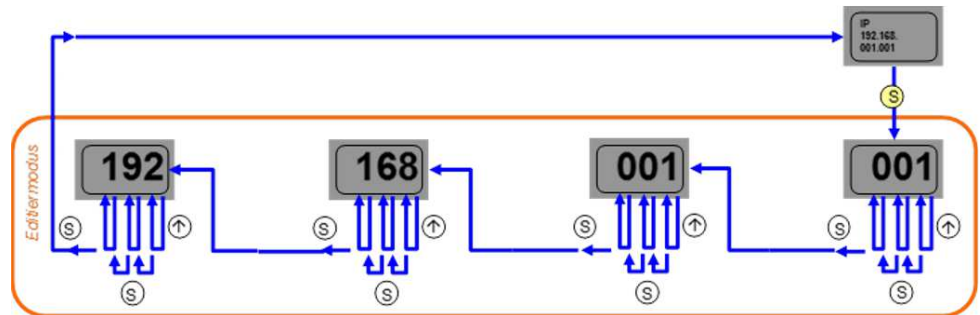

- In the Network Configuration menu, select IP / Subnet or Gateway Address.
- Press the set button long to switch to edit mode.
- Press the arrow key briefly to change the number.
- Press the Set button briefly to move to the next position.
- After the last digit, press the set button briefly to move to the next octet of the address or to accept the new number after the last octet.



Note
The module has to be restarted to work with the new configuration.

8.11. Module information

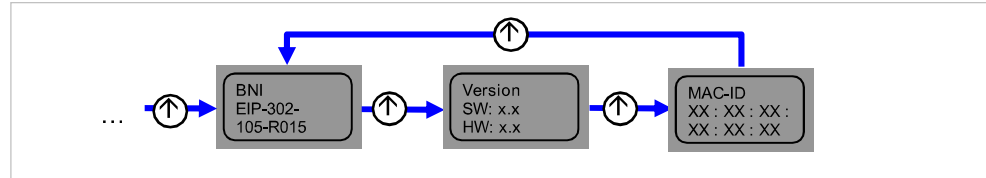

- By short-time keypress on arrow key you can scroll through module information menu.
- Informations are the product name, the module revisions and the MacID.

8.12. General Informations

- Longtime keypress for „fast scrolling“ in editing mode
- 10 seconds without keypress results in leaving actual screen and entering the default screen mode (4th octet of ip address). Unsaved changes gets lost
- Differences between new configuration and the configuration the module is working with are shown by a unequal-symbol. In this case the time to default screen is only 5 seconds.
- In editing mode the screen flashes. In fast scroll mode the screen is flickering
- If the module receives a single ping, the word “ping” is shown in the display screen for a few seconds. Afterwards the screen is reset to the screen which had been shown before. By short-time key press on set key the ping-mode can be left preterm.
- If the module receives a double ping, the word “ping” is shown in the display. This screen can be left only by short-time key press on set key. The screen shown before ping gets viewed again.
- The Led function at the display leds can be defined user specific by setting some bits in the process data inputs.
- The function plc-lock can also be used by setting a bit in the process data inputs.



Note:

Editing mode can not be chosen in display if the plc lock bit in process data inputs is. (See bit layout process data outputs)

9 Webserver

9.1. General Information

The BNI fieldbus module contains an integrated web server for retrieving detailed device information and for configuring the device.

To use the web interface you must first ensure that the module has been correctly integrated into your network. In addition the IP subnet of the BNI module must be accessible from the PC on which the browser is running. Please use Internet Explorer 10 or newer as the browser; older versions may result in display problems.

For open a connection with the web server, enter the IP address of the module in the address line of the browser. The homepage then appears with the essential device information.

The screenshot displays the web interface for the Balluff BNI PNT-302-105-Z015 module. The interface includes a navigation bar with the Balluff logo, the product name, and icons for Home, Login, Config, Log, and Info. The main content area is titled "Module Information" and lists the following details:

Product Name:	BNI PNT-302-105-Z015
Order Code:	BNI0052
Name:	MyNiceModule
Location:	73765 Neuhausen a.d.F., Germany
Contact:	Balluff GmbH
Firmware Revision:	3.2
Hardware Revision:	6
Station name:	myweb
IP Address:	192.168.0.4
Subnet Mask:	255.255.255.0
Gateway Address:	0.0.0.0
MAC Address:	00:19:31:3F:FF:32
Link Speed Port 1:	100 Mbit/s FULL
Link Speed Port 2:	No Link
PLC Lock:	No





Below the information is the PROFIBUS NET logo. To the right is a photograph of the physical module, which features eight RJ45 ports arranged in two columns of four. The top-left port is labeled "In/Out". Above the ports are two sets of status LEDs, each with two indicators. The bottom of the image shows the "LED Legend" label.

9.2. Navigation / Info The navigation bar is located in the upper area of the window, which allows you to switch between the various dialogs of the web interface. To do this click on the corresponding icon.

When the "Info" tab is selected the following overview appears:

BALLUFF BNI PNT-302-105-Z015 Home Login Config Log **Info**

Information

-  Show Module and Port Status
-  Administrator Login
-  Configure the Fieldbus Gateway
-  Logging and Diagnosis
-  Display this help window

Balluff GmbH
 Schurwaldstraße 9
 73765 Neuhausen a.d.F.
 Germany

Telefon: +49 (0) 7158 173-370
 Fax: +49 (0) 7158 173-5010
 E-Mail: balluff@balluff.de
 Web: <http://www.balluff.com>

Copyright © 2017 Balluff GmbH

The "BALLUFF" logo at upper right links to the international Balluff homepage.

9.3. Login/Logout

To make configuration settings on the fieldbus module using the web interface, you must first log in. Functionalities which cannot be used without logging in are indicated by the grayed out buttons.

The default password is:

BNI PNT-XXX-XXX-XXXX	"BNIPNT"
BNI EIP-XXX-XXX-XXXX	"BNIEIP"
BNI ECT-XXX-XXX-XXXX	"BNIECT"

The password cannot be changed!

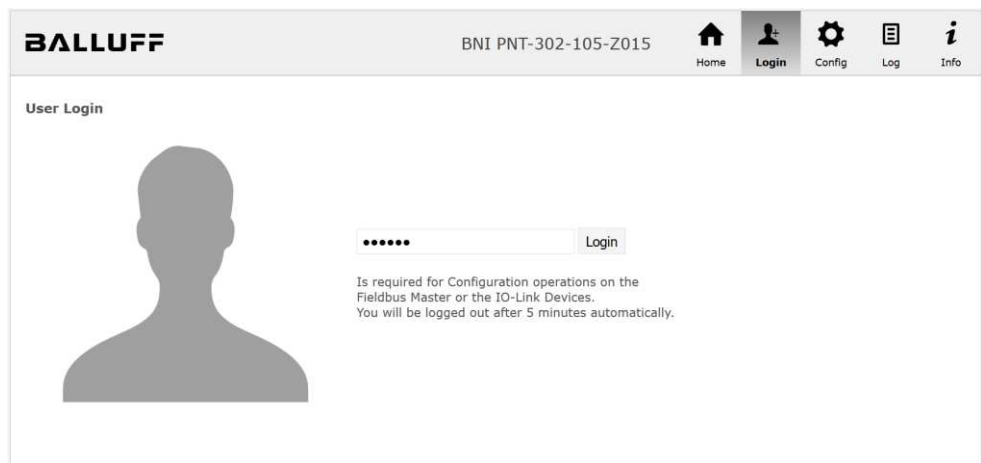

After successfully logging in the dialogs are shown as follows:

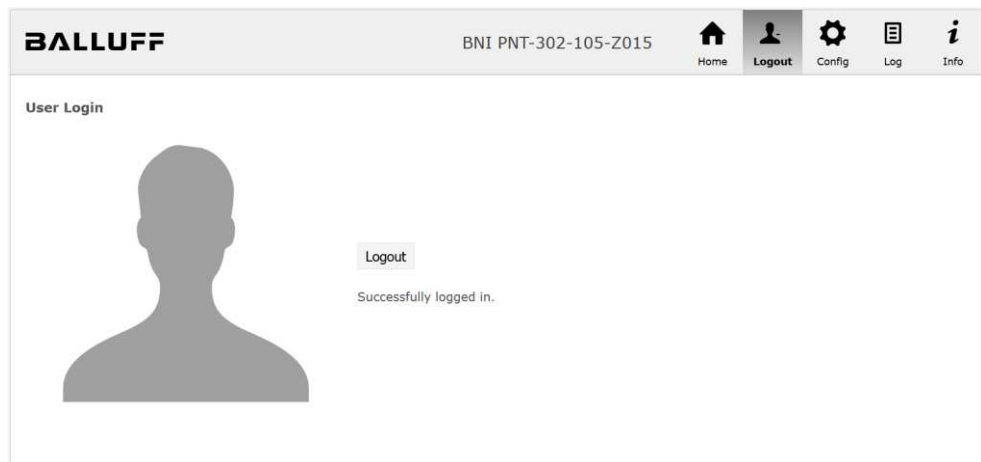

Use the "Logout" button to log out again. After 5 minutes of no interaction with the Webservice the user is automatically logged out.

i Note
 For security reasons the fieldbus module shows only one login at a time with configuration access. Reading (without logging in) is however possible from multiple PCs at the same time on the fieldbus module.

9.4. "Home" dialog

Under "Home" you are given the essential information about the fieldbus itself and its network activity. You are also shown whether the configuration block was enabled by the controller (PLC).

Information is also shown about the current process data and the status of the module via the corresponding LEDs. After selecting "LED Legend" a Help dialog appears which explains the meaning of the LEDs

BALLUFF
BNI PNT-302-105-Z015

Home
 Logout
 Config
 Log
 Info

Module Information

Product Name: BNI PNT-302-105-Z015
 Order Code: BNI0052
 Name: MyNiceModule
 Location: 73765 Neuhausen a.d.F, Germany
 Contact: Balluff GmbH
 Firmware Revision: 3.2
 Hardware Revision: 6

Station name: myweb
 IP Address: 192.168.0.4
 Subnet Mask: 255.255.255.0
 Gateway Address: 0.0.0.0
 MAC Address: 00:19:31:3F:FF:32
 Link Speed Port 1: 100 Mbit/s FULL
 Link Speed Port 2: No Link
 PLC Lock: No



LED Legend

PNT:

Module LED Functions

Indicator	Green	Red	Yellow
US	OK	Flow	
UA	OK	Flow	Flow
SF	Section error	IO-Link service	
BF	No config	No data exchange	
100	Connected	Not connected	
LK	Link activity	No link activity	

Port LED Functions

IO	0	1
IO-Link	n.c.	IO-Link
IO-Link	n.c.	IO-Link
IO-Link	IO-Link	IO-Link

EIP:

Module LED Functions

Indicator	Green	Red	Yellow
US	OK	Flow	
UA	OK	Flow	Flow
Mod	IO-Link error	Config Error	
Net	No config	No data exchange	Connected
100	100 Mbit/s	10 Mbit/s	Timeout
LK	Link activity	No link activity	

Port LED Functions

IO	0	1
IO-Link	n.c.	IO-Link
IO-Link	n.c.	IO-Link
IO-Link	IO-Link	IO-Link

> LED Legend

9.5. "Config" dialog The configuration page enables configuration of the module. You can change the module information texts and the (for EIP) IP-Configuration.

PNT / ECT:

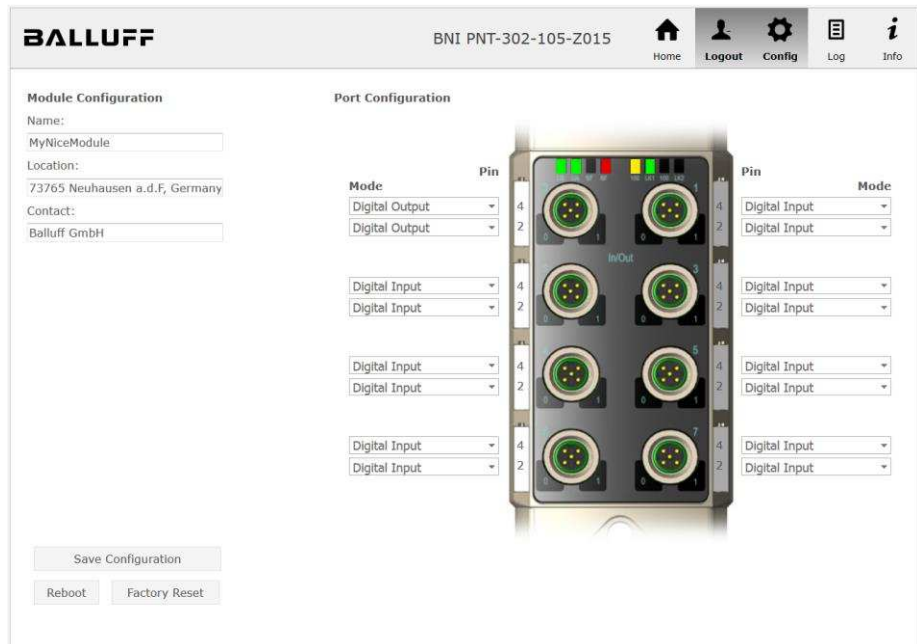

EIP:



The parameter set "Module Configuration" on the left side is used by clicking "Save Configuration" and permanently stored in the device. The "Reboot" button reboots the device as if the power to the module had been turned off and on again. Clicking on "Factory Reset" deletes the configuration and log files saved in the device and then performs a reboot, so that the device is restored to the default factory configuration as on delivery.

9.6. "Log" dialog This dialog provides general service information about the device as well as a logging function. The upper table (see screenshot below) contains important information for all service inquiries.

Note
 If you have a detailed question about a specific situation, send us a screenshot of this Web site or print the site as a PDF.

Logging shows events which have occurred in chronological order. This provides a tool for detailed troubleshooting in equipment.

The screenshot shows the BALLUFF web interface for device BNI PNT-302-105-Z015. The top navigation bar includes Home, Login, Config, Log, and Info. The 'Information' section displays the following data:

Product name:	BNI PNT-302-105-Z015	Browser time:	2017-01-23 15:58:00.039
Firmware revision:	3.2	System uptime:	4 mins 46 secs 959 msecs
MAC address:	00:19:31:99:CA:32	Free flash space:	2068 KB
IP address:	192.168.0.4	Web version:	2.0.110
Browser version:	Firefox 50.0		

The 'Log' section includes buttons for 'Set module time', 'Clear Log', and 'Update Log'. Below is a table of log entries:

No.	Severity	Date	Origin	Message
0	Notice	2000-01-01 00:00:00.426	SYS	System startup (Oct 20 2016, 14:57:42)
1	Notice	2000-01-01 00:00:00.456	SYS	Set MAC address: 00:19:31:99:CA:32
2	Informational	2000-01-01 00:00:00.459	SYS	Configuration updated with new data from device file
3	Notice	2000-01-01 00:00:01.959	ETH	Port 0: Link Up (100 MBit/s, full duplex)
4	Notice	2000-01-01 00:04:42.911	WEB_IF	Login successful, IP address: 192.168.0.50
5	Notice	2000-01-01 00:04:45.129	WEB_IF	Logout, IP address: 192.168.0.50

Events are classified using the "Severity" column:

Internal Error (Emergency, Alert, Critical)

→ The fieldbus module has detected a fault in itself (hardware or software) which should not occur during normal operation. If this happens, the module must be serviced or replaced.

External Error (Error, Warning)

→ The fieldbus module has detected what may be a non-permissible event which is affecting the module from the outside. The system may require troubleshooting.

Event (Informational, Notice)

→ The fieldbus module has detected an important normal operating event and reports it. These may include for example configuration actions over the web interface and other configuration interfaces which are also recorded.

Clicking on "Set Module Time" sends the current browser time to the fieldbus module but does not permanently store it. After a reset, reboot or loss of power the time begins to run again from the year 2000.

Clicking on "Update Log" refreshes the display, and "Clear Log" deletes all entries. The log entries are stored in a ring buffer.

10.1. Included material

The BNI EIP consists of the following components:

- I/O-block
- 4 blind plugs M12
- Ground strap
- Screw M4x6
- 20 labels

10.2. Order code

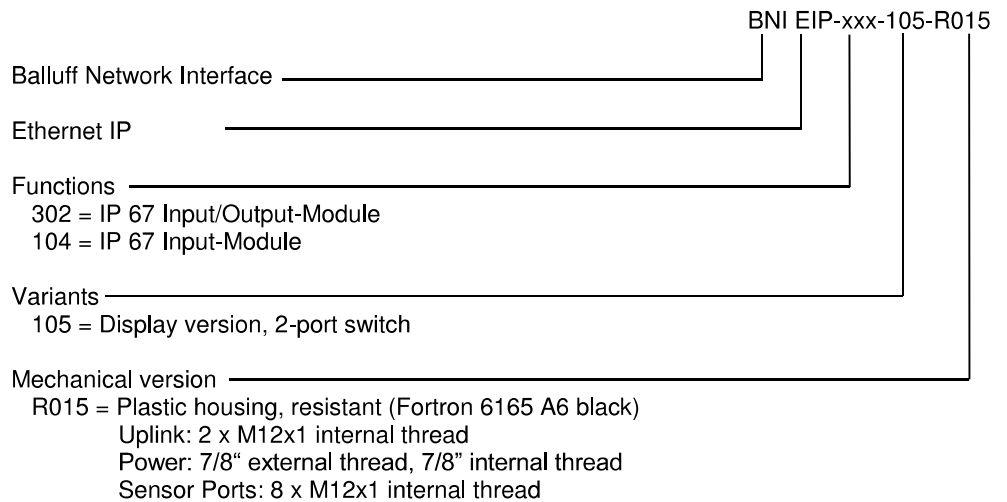

10.3. Order Information

Product ordering code	Order code
BNI EIP-104-105-R015	BNI008Y
BNI EIP-302-105-R015	BNI008P

www.balluff.com

Balluff GmbH
Schurwaldstrasse 9
73765 Neuhausen a.d.F.
Germany
Tel. +49 7158 173-0
Fax +49 7158 5010
balluff@balluff.de