

Short instructions
Cooling water control panel

ZZ0057

UK

701720 12 / 2018

1 System description

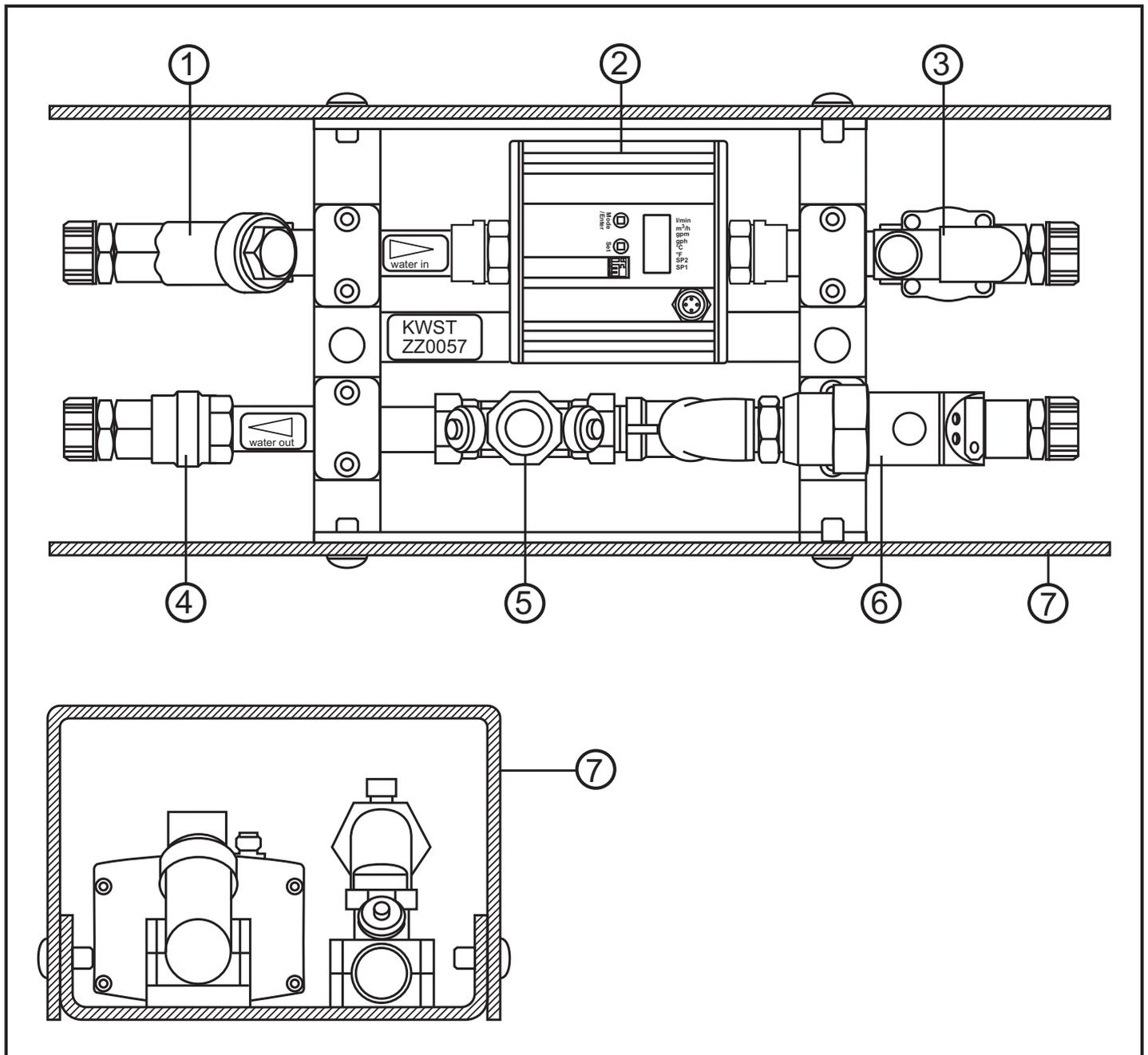

1	Filter	Filters solids to avoid clogging / damage to the system.
2	Flow sensor	Monitors and indicates the cooling water flow rate. The setting of two switch points enables detection of: <ul style="list-style-type: none"> • excess flow (leakage / burst pipes / lost tips) • low flow (clogged / damaged pipes)
3	Water stop valve	Closes the water supply to the system in case of failure and prevents water spillage.
4	Backstop	Prevents cooling water loss through the return pipe in case of failure (broken tip / burst pipe).

5	Regulating valve	Regulation of the flow rate. Adjustable in 6 steps, preset: step 3.
6	Pressure sensor	Monitors the operating pressures, very fast response times are attained if pressure falls (broken tips).
7	Cover	Protection against mechanical damage.

2 Functions and features

DE

Pressure Equipment Directive (PED)

The units comply with the Pressure Equipment Directive and are designed and manufactured for group 2 fluids in accordance with the sound engineering practice.

Use of group 1 fluids on request.

3 Setting of the flow sensor

The flow sensor monitors the flow rate in the supply pipe by means of a window function. This is achieved by setting the output function of the two outputs: OU1 and OU2 = Fno, window / normally open.

With this setting an acceptable range is monitored.

The flow rate depends on the water supply and the set-up of the welding tongs.

The setting of the switch-on points (SP1, SP2) and the switch-off points (rP1, rP2) depends on the installation.

Optimum monitoring of the start up characteristics as well as processrelated flow fluctuations during operation is possible via additional monitoring times in the robot software.

3.1 Parameter setting

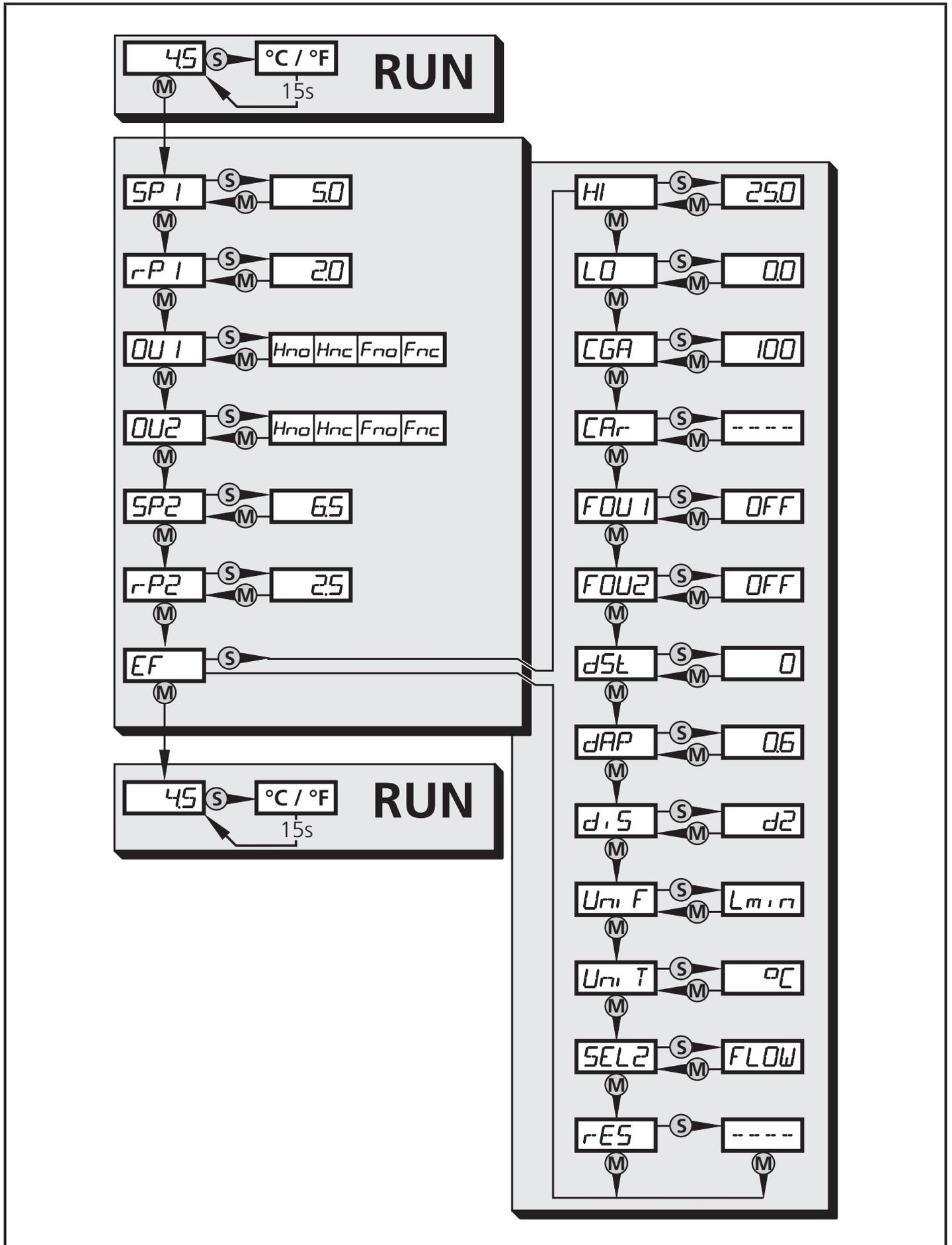

*The values of SP1, rP1, SP2, rP2 depend on the installation

	[Mode/Enter] button	▶ selection of the parameters
	[Set] button	▶ display of parameter values (press briefly) ▶ setting of parameter values (press > 5 s)
	[Mode/Enter] button	▶ acknowledgement of the parameter values

1.1 Operating principles

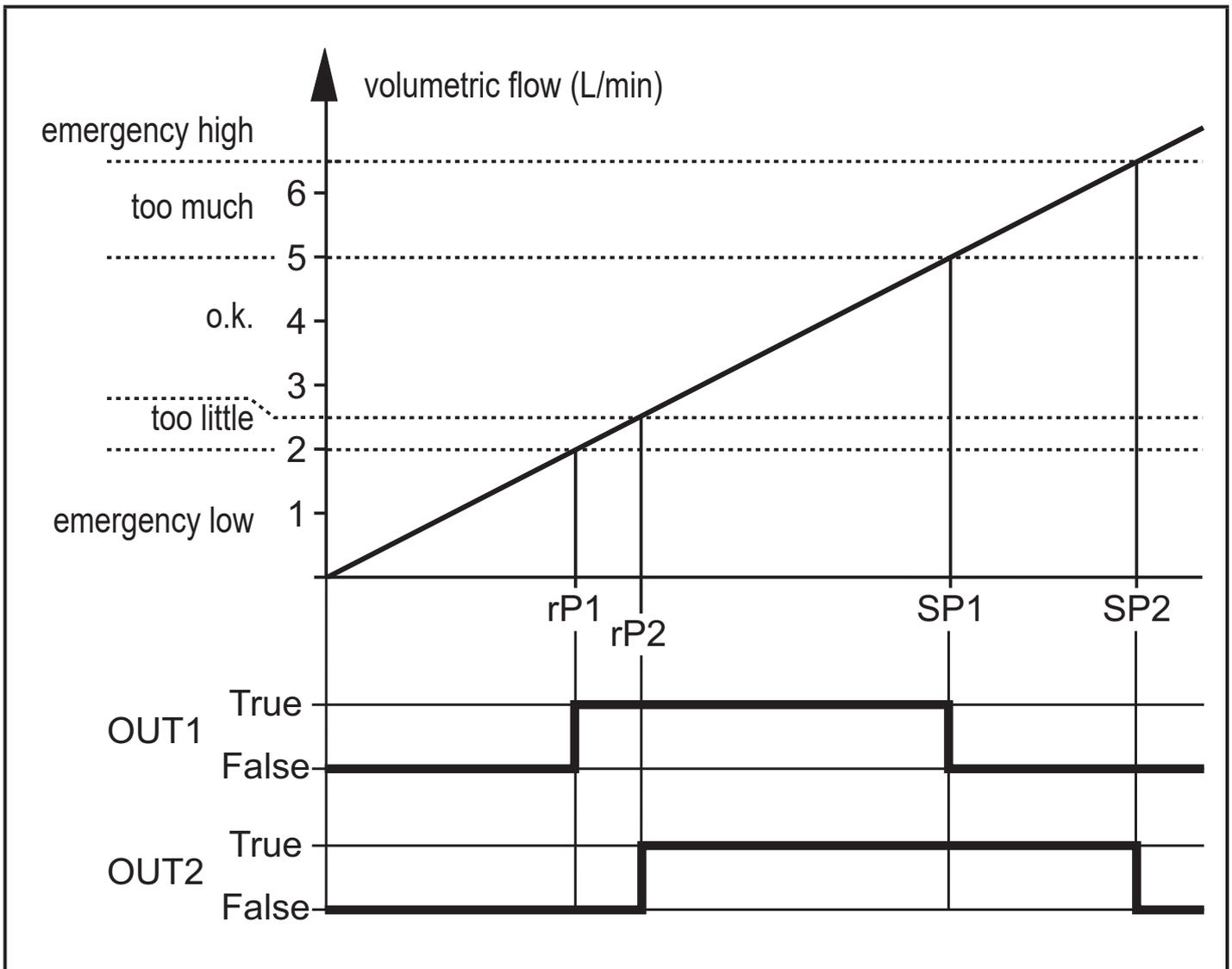

1.2 Monitoring times in the robot software

REAL W_ZEIT_EX_ZUW_Z1=2.0	Monitoring time in sec for emergency low water
REAL W_ZEIT_ZUW_Z1=10.0	Monitoring time in sec for too little water
REAL W_ZEIT_EX_ZUV_Z1=1.0	Monitoring time in sec for emergency high water
REAL W_ZEIT_ZUV_Z1=10.0	Monitoring time in sec for too much water
REAL W_ZEIT_EX_ZUW_ST_Z1=5.0	Emergency low water when the water starts to flow
REAL W_ZEIT_ZUW_ST_Z1=20.0	Too little water in sec when the water starts to flow
REAL W_ZEIT_DRUCK_Z1=1.0	Monitoring time in sec pressure fault
REAL W_ZEIT_DRUCK_ST_Z1=2.0	Pressure fault when the water starts to flow

1 Setting of the pressure sensor

The pressure sensor monitors the operating pressure in the return pipe.

The operating pressure depends on the water supply.

The setting of the switch-on point (SP1) and the switch-off point (rP1) depends on the installation.

The switch point is to be set to a value just below the operating pressure to achieve the shortest possible response time. Ensure that pressure fluctuations due to the system do not trigger a switching operation.

1.1 Parameter setting

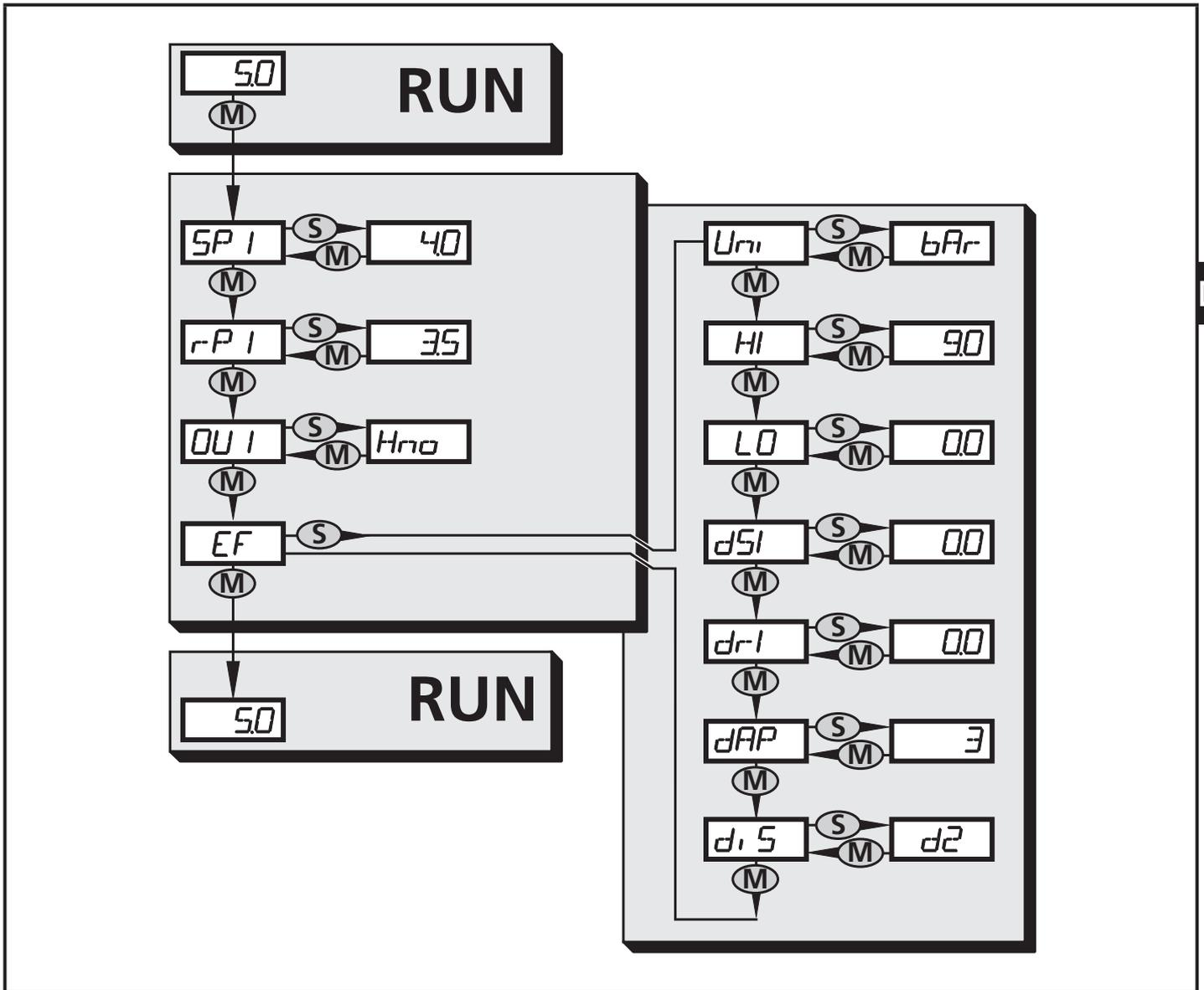

*The values of SP1, rP1, SP2, rP2 depend on the installation

	[Mode/Enter] button	▶ selection of the parameters
	[Set] button	▶ display of parameter values (press briefly) ▶ setting of parameter values (press > 5 s)
	[Mode/Enter] button	▶ acknowledgement of the parameter values

DE