



Operating instructions
Electronic level sensor

UK

LR8320

LXxxxx

80276341 / 00 01 / 2022

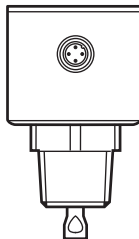

Contents

1	Preliminary note.....	4
1.1	Symbols used.....	4
2	Safety instructions	4
3	Items supplied.....	5
4	Getting started	5
4.1	Installation, Electrical connection	5
4.2	Parameter setting	5
4.3	Example application	5
5	Functions and features	6
5.1	Applications	6
5.2	Restriction of the application area	6
6	Function.....	7
6.1	Measuring principle	7
6.2	Set-up via IO-Link.....	8
6.3	Switching function.....	8
6.4	Probes for different tank heights.....	9
6.5	Defined state in case of a fault	9
6.6	IO-Link	9
7	Installation.....	9
7.1	Installation location / environment	9
7.1.1	Minimum distances for installation in closed metal tanks	10
7.1.2	Installation in pipes (bypass pipe, still pipe)	11
7.1.3	Applications with viscous and fast flowing media	11
7.1.4	Heavy soiling	12
7.1.5	Fill openings	12
7.1.6	Heavy foam build-up and turbulence.....	13
7.1.7	Notes on tank adjustment.....	14
7.2	Installation of the probe	15
7.3	Probe length	16
7.3.1	Shorten the probe.....	16
7.3.2	Determine probe length.....	16
7.4	Installation of the unit.....	16
7.4.1	Installation to 3/4" NPT process connection directly in the tank lid	17

7.4.2 Installation in the tank lid using a 3/4" NPT flange plate.....	17
7.4.3 Installation in open metal tanks	18
7.4.4 Installation in plastic tanks.....	18
7.5 Alignment of the sensor housing	19
8 Electrical connection.....	20
9 Operating and display elements	21
10 Parameter setting	21
10.1 Parameter setting using PC and USB IO-Link master.....	21
10.2 Parameter setting via the memory plug.....	22
10.3 Parameter setting during operation	22
10.4 Adjustable parameters.....	22
11 Operation	24
11.1 Single probe.....	24
11.2 Function check.....	24
11.3 Operating and diagnostic messages via IO-Link	24
11.4 Output response in different operating states	25
12 Technical data and scale drawing.....	25
13 Maintenance / transport.....	25
14 Factory setting	26
15 Notes on parameter setting via IO-Link	27
15.1 Unit locking / data storage (as from IO-Link V1.1).....	27

1 Preliminary note

1.1 Symbols used

- ▶ Instructions
- > Reaction, result
- [...] Designation of keys, buttons or indications
- Cross-reference



Important note

Non-compliance may result in malfunction or interference.



Information

Supplementary note.

2 Safety instructions

- The device described is a subcomponent for integration into a system.
 - The manufacturer of the system is responsible for the safety of the system.
 - The system manufacturer undertakes to perform a risk assessment and to create a documentation in accordance with legal and normative requirements to be provided to the operator and user of the system. This documentation must contain all necessary information and safety instructions for the operator, the user and, if applicable, for any service personnel authorised by the manufacturer of the system.
- Read this document before setting up the product and keep it during the entire service life.
- The product must be suitable for the corresponding applications and environmental conditions without any restrictions.
- Only use the product for its intended purpose (→ Functions and features).
- Only use the product for permissible media (→ Technical data).
- If the operating instructions or the technical data are not adhered to, personal injury and/or damage to property may occur.
- The manufacturer assumes no liability or warranty for any consequences caused by tampering with the product or incorrect use by the operator.
- Installation, electrical connection, set-up, operation and maintenance of the unit must be carried out by qualified personnel authorised by the machine operator.
- Protect units and cables against damage.

3 Items supplied

- Level sensor LR8320 or LXxxxx
- Operating instructions

In addition, the following is necessary for installation and operation (→ Accessories):

- Probe (→ 11.1)
- Mounting material (→ 11.1)



Only use accessories from ifm electronic gmbh! The optimum function is not ensured when using components from other manufacturers.



Accessories: www.ifm.com

4 Getting started

For the most frequent applications the quick set-up described below is possible. The quick set-up does not replace observance of the other chapters.

4.1 Installation, Electrical connection

- ▶ Install the unit correctly (→ 7) and (→ 8)

4.2 Parameter setting



On delivery the unit is not operational.

Notes on parameter setting via IO-Link (→ 15)

4.3 Example application

- ▶ Enter probe length (parameter [LEnG]). Example: [LEnG] = [39.4] inch.
 - ▶ Select the medium (parameter [MEdI]). Example: [MEdI] = [MId].
 - ▶ Transfer the sensor data to the unit.
 - ▶ Carry out tank adjustment according to the installation (button [tREF xxx]).
 - ▶ Now all other settings can be carried out.
- > **The unit is ready for operation.**
- ▶ Check whether the unit operates correctly.

5 Functions and features

The unit continuously detects the level in tanks.



A PC with USB IO-Link master or a correspondingly programmed memory plug or a configured IO-Link environment is required to set the parameters (→ 6.6), (→ 10).



According to the current state of science the operation of the unit can be classified to be harmless to human health. The radiated energy of the microwaves is, for example, much below that of mobile phones.

5.1 Applications

- Water, water-based media
- Compatible with 3/4" NPT process connections
- For applications under difficult environmental conditions (e.g. weather or harsh cleaning processes) → Technical data sheet.

Application examples:

- Detection of coolant emulsion in a machine tool.
- Detection of cooling water in an industrial cooling system.
- Detection of cleaning liquid in a parts cleaning system.

5.2 Restriction of the application area



Incorrect measurements / signal loss may be caused by the following media:

- highly absorbing surfaces (e.g. foam)
- intensely bubbling surfaces
- Media which are very inhomogeneous, separate from each other thus forming separation layers (e.g. oil layer on water).
 - ▶ Check the function by performing an application test.
 - ▶ Installation in a steady area (→ 7.1.6)
 - > In case of signal loss, the unit switches the outputs to a defined state (→ 6.5).
- Use the product only for media to which the wetted materials are sufficiently resistant (→ Technical data sheet).
- The unit is not suitable for bulk materials (e.g. plastic granulates) and media with a dielectric constant < 5 (e.g. oils).

- The unit is not suitable for applications where the probe is subjected to permanent and high mechanical stress (e.g. heavy movement of viscous media or fast flowing media).
- When used in plastic tanks, deterioration caused by electromagnetic interference from other devices may occur (noise immunity to EN61000-6-2). Refer to: (→ 7.4.4).
- When operating with a single probe and small tanks (probe lengths shorter than 200 mm and less than 300 mm distance to the tank wall), interference from the tank (resonances) may occur in rare cases.
Corrective measures: (→ 7.1)
- Not suited for operation with coaxial probe.

6 Function

6.1 Measuring principle

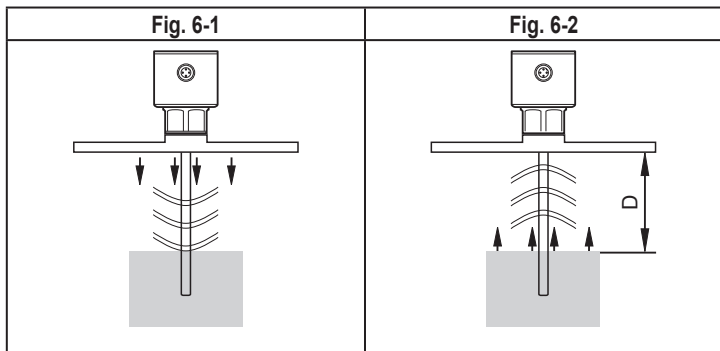

The unit operates on the principle of guided wave radar. It measures the level using electromagnetic pulses in the nanosecond range.

The pulses are transmitted by the sensor head and guided along the probe (Fig. 6-1). When they hit the medium to be detected, they are reflected and guided back to the sensor (Fig. 6-2). The time between transmitting and receiving the pulse directly relates to the travelled distance (D) and the current level. The reference for distance measurement is the lower edge of the process connection.

6.2 Set-up via IO-Link

The device parameters are set via the IO-Link interface (→ 6.6) and (→ 10).

6.3 Switching function

The unit signals via the switching outputs (OUT1...OUT4) that a set limit has been reached or that the level is below the limit.

! The switching limits refer to the lower probe end.

The following switching functions can be selected:

- Hysteresis function / normally open (Fig. 6-4): [oux] = [Hno]
- Hysteresis function / normally closed (Fig. 6-4): [oux] = [Hnc]

! First the set point (SP) is set, then the reset point (rP) with the requested difference.

- Window function / normally open (Fig. 6-5): [oux] = [Fno]
- Window function / normally closed (Fig. 6-5): [oux] = [Fnc]

! The width of the window can be set by means of the difference between [FH] and [FL]. [FH] = upper value, [FL] = lower value.

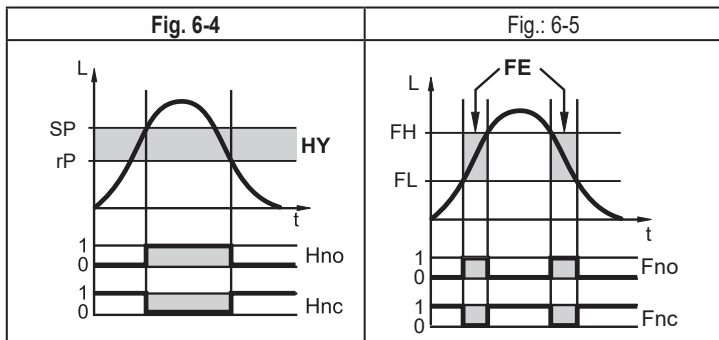

L: level

HY: hysteresis

FE: window

For each switching output a switch-on and switch-off delay of max. 60 s can be set (e.g. for especially long pump cycles); (→ 10.4).

6.4 Probes for different tank heights

The unit can be installed in tanks of different sizes. Probes in different lengths are available. To adapt to the tank height, each probe can be shortened. The minimum probe length is 100 mm, the maximum probe length 2000 mm.

6.5 Defined state in case of a fault

- In case of a fault a state can be defined for each output.
- If a fault is detected or if the signal quality is below a minimum value, the outputs pass into a defined state. For this case the response of the outputs can be set via the parameter [FOUx] (→ 10.4).
- Temporary loss of signal caused e.g. by turbulence or foam build-up can be suppressed by a delay time (parameter [dFo] (→ 10.4)). During the delay time the last measured value is frozen. If the measured signal is received again in sufficient strength within the delay time, the unit continues to work in normal operation. If, however, it is not received again in sufficient strength within the delay time, the outputs pass into the defined state.



In case of heavy foam build-up and turbulence, note the examples of how to create a steady area (→ 7.1.6).

6.6 IO-Link

This unit has an IO-Link communication interface which requires an IO-Link capable module (IO-Link master) for operation.

The IO-Link interface enables direct access to the process and diagnostic data and provides the possibility to set the parameters of the unit during operation.

In addition, communication is possible via a point-to-point connection with a USB IO-Link master.

The IODDs necessary for the configuration of the unit, detailed information about process data structure, diagnostic information, parameter addresses and the necessary information about the required IO-Link hardware and software can be found at www.ifm.com.

7 Installation

7.1 Installation location / environment

- Vertical installation from the top is preferred.
- ▶ Observe the notes on tank adjustment (→ 7.1.7).
- For installation in open tanks: (→ 7.4.3)
- For installation in plastic tanks: (→ 7.4.4)

- When operating the unit in small tanks (probe lengths shorter than 200 mm and less than 300 mm distance to the tank wall), mount the unit off-centre (eccentrically) to prevent possible interference from tank resonances.

7.1.1 Minimum distances for installation in closed metal tanks

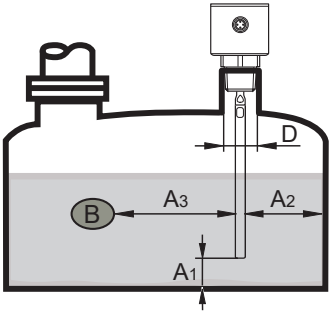
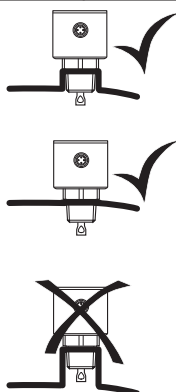
Fig. 7-1	Fig. 7-2
	<p style="text-align: center;">without adjustment</p> 
Installation distances with adjustment (→ 7.1.7)	Installation distances without adjustment
A1: 10 mm *)	A1: 10 mm *)
A2: 20 mm	A2: 40 mm to even tank walls 50 mm to uneven tank walls (e.g. supports)
A3: 20 mm to structures in the tank (B) 50 mm to other sensors type LR	A3: 50 mm to structures in the tank (B) 50 mm to other sensors type LR
D: \varnothing 30 mm if installed in a connection piece	D: No connection piece allowed according to fig. 7-2

*) Alternatively: Fix probe at the tank bottom. Observe notes (→ 7.1.3).



For installation in connection pieces:
If a pipe is used to make the connection piece (Fig. 7-3), it must not protrude into the tank. The installation causes interfering reflections which are not suppressed by the tank adjustment.

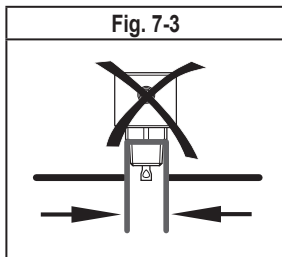

7.1.2 Installation in pipes (bypass pipe, still pipe)

The internal pipe diameter (d) must at least have the following value:

d	With adjustment (→ 7.1.7)	Without adjustment
Metal pipe	∅ 30 mm	∅ 100 mm with [MEdl] = [HIGH] ∅ 200 mm with [MEdl] = [Mid] (→ 10.4)
Plastic pipe *)	∅ 200 mm	

*) Observe notes (→ 7.4.4).

► If possible, mount the unit off-centre (eccentrically).



Depending on the operating conditions (e.g. viscous medium / flow) the use of centring pieces is recommended (→ Accessories).



The pipe must not be shorter than the probe.

7.1.3 Applications with viscous and fast flowing media

► If possible, install the unit in a bypass pipe or a still pipe (→ 7.1.2).

► In addition, the following aspects have to be considered:

- The probe must not be in contact with the tank wall / structures in the tank. If required, increase the minimum lateral distances.
- If possible, fix the probe at the tank bottom so that it is electrically conductive, e.g. using a sleeve (Fig. 7-4 and 7-5) or a drill hole in the tank bottom (Fig. 7-6).
- For installation according to Fig. 7-5: Increase parameter [LEnG] by (h) to offset the length increase (h) (→ 10.4).

- For installation according to Fig. 7-6: Reduce parameter [LEnG] by (t) to offset the immersion depth (t) (→ 10.4).

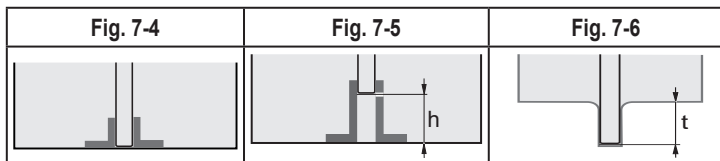

 If the probe is fixed at the tank bottom, a low level may already be detected with empty tank.

- Adapt switch points if necessary.
- Check the correct function (in particular with empty tank).

7.1.4 Heavy soiling

If the medium is highly polluted, there is the risk that a bridge forms between the probe and the tank wall / inner wall of the pipe or structures in the tank.

- Increase minimum distances depending on the pollution intensity.

7.1.5 Fill openings

Do not install the unit in the immediate vicinity of a fill opening (Fig. 7-7).

If possible, install a fill pipe (A) in the tank (Fig. 7-8). Keep to the indicated installation distances; if necessary, carry out a tank adjustment.

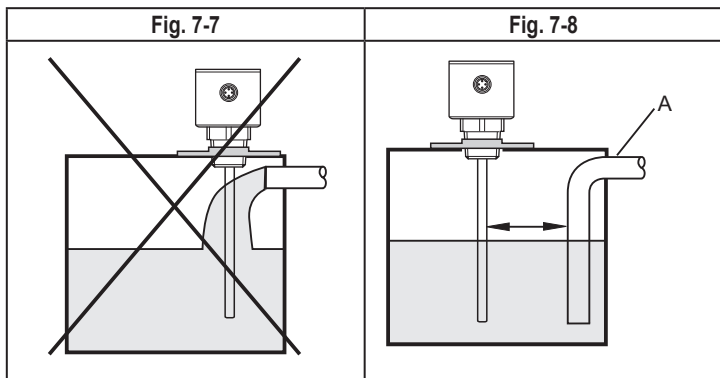

7.1.6 Heavy foam build-up and turbulence



Heavy foam build-up and turbulence may lead to incorrect measurements.

To prevent this:

- ▶ Install the sensor in a steady area.

Examples how to create a steady area:

- Installation in metal bypass or metal still pipe (Fig. 7-9).
- Separation of the installation location by metal sheets / perforated sheets (without figure).

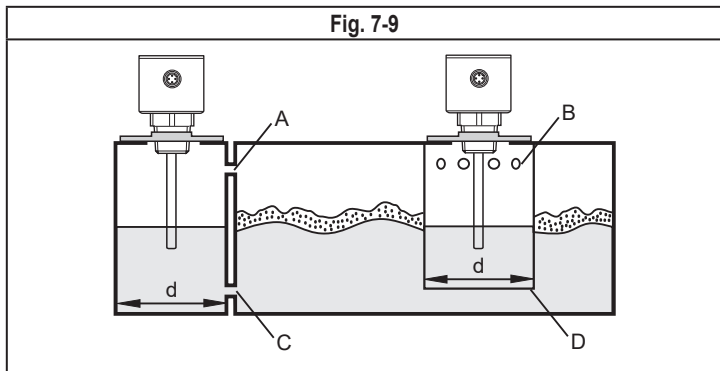

d: minimum diameter (→ 7.1.2)



The access (A, B) must be above the max. level.

The access (C, D) must be below the min. level.

This ensures that neither foam nor turbulence impact the measurement. In addition soiling (e.g. by solids in the medium) can also be avoided.



With increased foam build-up the setting [MEdl] = [Mld] is recommended (→ 10.4).

7.1.7 Notes on tank adjustment



Tank adjustment (parameter [tREF]) reduces the effect of interference and ensures a higher excess gain in difficult application conditions.



Only carry out a tank adjustment with the unit installed and preferably with empty tank.

Two options are available for tank adjustment:

[Emty] = Adjustment of the complete probe (recommended). For this option the tank must be completely empty!

[FLnG] = Adjustment of the upper 50 mm from the lower edge of the process connection. For this option the tank may be partly filled. The level must, however, not be higher than max. 300 mm below the process connection.

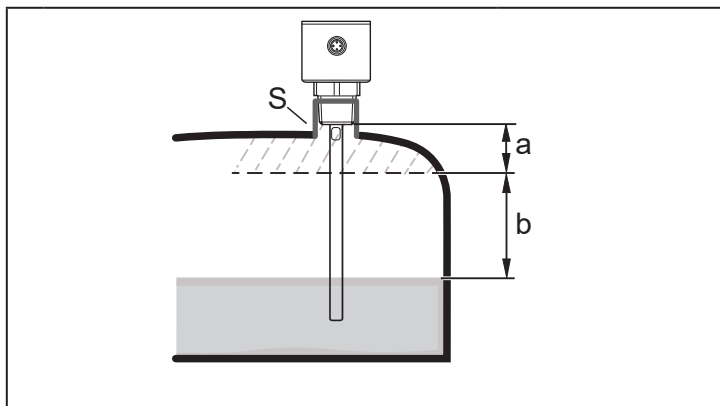

a: adjustment distance 50 mm with option [FLnG] S: connection piece
b: safety distance to the level ($b \geq 250$ mm)



For probe lengths $L < 300$ mm no tank adjustment is possible. The parameter [tREF] is then not available. In this case:

► Adhere to all indicated installation distances (→ 7.1).



No tank adjustment is necessary if all installation distances are adhered to. The unit is then ready for operation without tank adjustment.



Only if data storage is required in an IO-Link application:

The tank adjustment is not saved via IO-Link. After a replacement it must be carried out again.

More information about data storage: (→ 15.1)

7.2 Installation of the probe

The probe is not supplied. It has to be ordered separately (→ 3).

- ▶ Screw the probe to the unit and tighten.
- ▶ Hold the probe at the point of attachment with a second screwdriver to stop it turning (Fig. 7-10).



Recommended tightening torque:
4 Nm.

For ease of installation and removal the probe connection can be rotated without restriction. Even if rotated several times, there is no risk of damage to the unit.

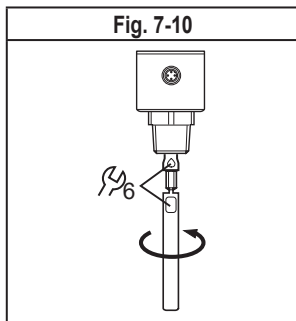

In case of high mechanical stress (strong vibration, moving viscous media) it may be necessary to secure the screw connection, e.g. by a screw retaining compound.



Substances such as screw retaining compounds may migrate into the medium.

- ▶ Make sure that they are harmless.

When using mechanical means of securing (e.g. tooth lock washer):

- ▶ Avoid protruding edges. They may cause interference reflection.

7.3 Probe length

7.3.1 Shorten the probe

The probe can be shortened to adapt to different tank heights.

 Ensure that the probe length is not below the minimum permissible probe length (L_{\min}) of 100 mm. The unit does not support probe lengths below 100 mm.

 For probe lengths < 300 mm no tank adjustment is possible (→ 7.1.7).

- ▶ Screw the probe to the unit.
- ▶ Mark the desired length (L) on the probe. The reference point is the lower edge of the process connection (Fig. 7-11).
- ▶ Remove the probe from the unit.
- ▶ Shorten the probe at the mark.
- ▶ Remove all burrs and sharp edges.
- ▶ Screw the probe to the unit again and tighten it (→ 7.2).

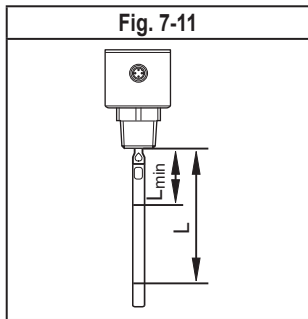

$L_{\min} = 100 \text{ mm}$

7.3.2 Determine probe length

- ▶ Precisely measure the probe length L . The reference point is the lower edge of the process connection (Fig. 7-11).
- ▶ Note down L . It is needed for setting the device parameters (→ 10.4).

7.4 Installation of the unit

 Before installing and removing the unit: Make sure that no pressure is applied to the system and that there is no medium in the tank that could leak. Also always take into account the potential dangers related to extreme machine and medium temperatures.

For installation in closed metal tanks, the tank lid serves as a launching plate R (Fig. 7-13 and 7-15). Observe the notes on the launching plate (→ 11.1).

7.4.1 Installation to 3/4" NPT process connection directly in the tank lid

- ▶ Apply a suitable sealing material (e.g. PTFE tape) to the sensor thread; otherwise lightly grease the with a suitable paste.
- ▶ Insert the unit into the process connection.
- ▶ Tighten it using a spanner. Tightening torque: 35 Nm.

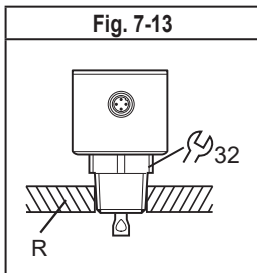

7.4.2 Installation in the tank lid using a 3/4" NPT flange plate

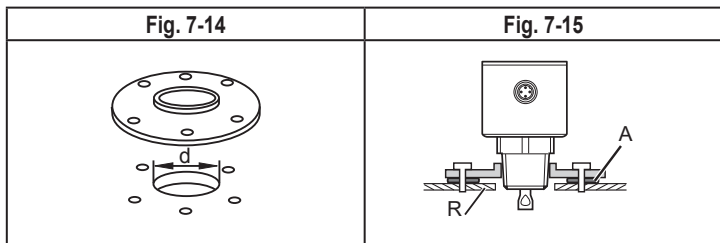

- ▶ Arrange for a hole in the tank lid. Observe diameter (d) to enable sufficient transfer of the measured signal to the probe (Fig. 7-14). The diameter (d) depends on the wall thickness of the tank lid:

Wall thickness [mm]	1...5	5...8	8...11
d [mm]	35	45	55

- ▶ Install the flange plate with 3/4" NPT process connection (→ Accessories) with the flat surface showing to the tank and fix it with appropriate screws.

! If necessary, a seal (A in fig. 7-15) can be inserted between flange plate and tank. Some flange plates are supplied with a seal. If this is not the case, use a suitable seal.

- ▶ Ensure cleanness and evenness of the sealing areas, especially if the tank is under pressure. Tighten the fixing screws sufficiently.
- ▶ Apply a suitable sealing material (e.g. PTFE tape) to the sensor thread; otherwise lightly grease the with a suitable paste.

- ▶ Insert the unit into the process connection.
- ▶ Tighten it using a spanner. Tightening torque: 35 Nm.

7.4.3 Installation in open metal tanks

- ▶ For installation in open metal tanks, use a metal fixture with 3/4" NPT process connection to install the unit. It serves as a launching plate (R); minimum size: 150 x 150 mm for a square fixture, 150 mm diameter for a circular fixture (→ 11.1).
- ▶ If possible, mount the unit in the middle of the fixture. Adhere to the specified installation distances according to (→ 7.1); if necessary, carry out a tank adjustment.

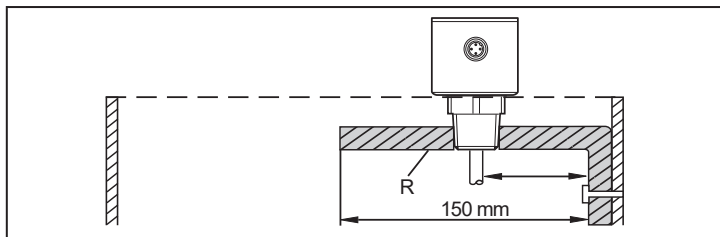

R: launching plate (→ Accessories)

- ▶ Lightly grease the sensor thread with a suitable paste.
- ▶ Insert the unit into the process connection.
- ▶ Tighten it using a spanner. Tightening torque: 35 Nm.

7.4.4 Installation in plastic tanks

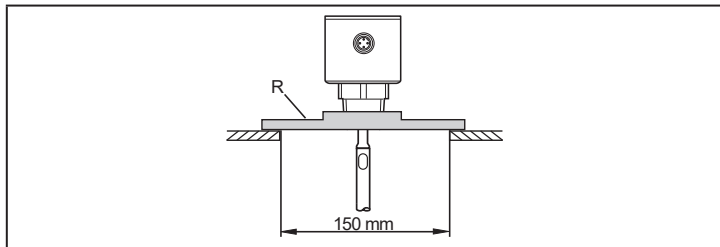

R: launching plate (→ Accessories)

To enable sufficient transfer of the measured signal, note in case of installation in plastic tanks or metal tanks with plastic lid:

- ▶ There must be a hole at least 150 mm in diameter in the plastic lid.
- ▶ For installation of the unit, a metal flange plate (launching plate, R) with 3/4" NPT process connection must be used which sufficiently covers the drill hole.
- ▶ Ensure a minimum distance (= 100 mm) between the probe and the tank wall. Adhere to the specified installation instructions according to (→ 7.1.2) to (→ 7.1.6); if necessary, carry out a tank adjustment.



When installed in plastic tanks, there may be deterioration caused by electromagnetic interference from other devices. Possible remedies:

- Attach a large-surface, metal screen at the outside of the tank. Check grounding concept; if necessary, change.
 - Eliminate sources of interference or reduce emissions from the source of interference taking electro-technical measures.
 - Installation in a metal pipe in the plastic tank.
- ▶ Lightly grease the sensor thread with a suitable paste.
 - ▶ Insert the unit into the process connection.
 - ▶ Tighten it using a spanner. Tightening torque: 35 Nm.

7.5 Alignment of the sensor housing

After installation, the sensor housing can be aligned. It can be rotated without restriction.



Even if rotated several times there is no risk of damage to the unit.

8 Electrical connection



The unit must be connected by a qualified electrician.

The national and international regulations for the installation of electrical equipment must be adhered to.

Voltage supply according to SELV, PELV.



For marine applications (if approval available for the device), additional surge protection is required.

► Disconnect power.

► Connect the unit as follows:

Core colours			
Pin	Socket	ifm	to DIN 47100
1	BN	brown	white
2	WH	white	brown
3	BU	blue	green
4	BK	black	yellow
5	GY	grey	grey
6	PK	pink	pink
7	VT	violet	blue

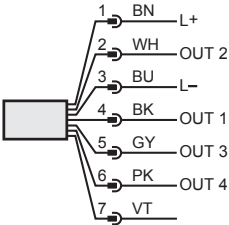
OUT1: switching output / IO-Link

OUT2...OUT4 switching outputs 2...4

Colours to ifm

Example circuits

4 x positive switching

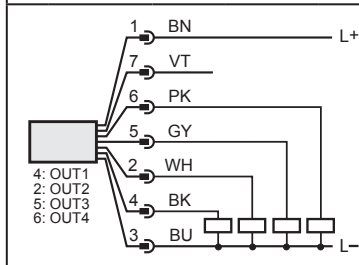

4 x negative switching

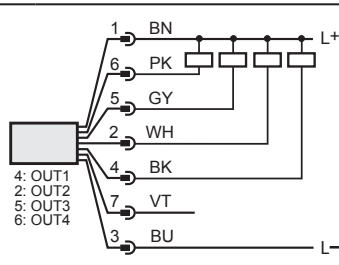



When operating voltage is applied to the unit for the first time, the basic settings must be entered first (→ 10). Only then is the unit ready for operation.

9 Operating and display elements

This unit version has no operating and display elements. For parameter setting (→ 10).



For units with display and operating elements → www.ifm.com.

10 Parameter setting

A PC with USB IO-Link master (→ 10.1), a correspondingly programmed memory plug (→ 10.2) or a configured IO-Link environment (→ 10.3) is required to set the parameters.

All parameters except tank adjustment (→ 7.1.7) can be set before installation and set-up of the unit or during operation (→ 10.3).



Changing parameters during operation can influence the function of the plant.

- ▶ Make sure that there will be no malfunctions / dangerous operation in your plant.

10.1 Parameter setting using PC and USB IO-Link master

- ▶ Prepare PC, software and master → observe the operating instructions of the respective units / software (→ 6.6).
- ▶ Connect the unit to the USB IO-Link master (→ Accessories).
- ▶ Follow the menu of the IO-Link software.
- ▶ Set the parameters, adjustable parameters (→ 10.4).
- ▶ Check if the parameter setting was accepted by the unit. If necessary, read sensor again.
- ▶ Remove USB IO-Link master and put the unit into operation (→ 11).

10.2 Parameter setting via the memory plug

Via a memory plug (→ Accessories), a parameter set can be written/transferred to the unit (→ 6.6).

- ▶ Load suitable parameter set (e.g. using a PC) to the memory plug
→ observe the operating instructions of the memory plug.
- ▶ Make sure that the sensor has the original factory settings.
- ▶ Connect the memory plug between sensor and socket.
- > When voltage is supplied, the parameter set is transferred from the memory plug to the sensor.
- ▶ Remove the memory plug and put the unit into operation (→ 10.4).



The memory plug can also be used to save the current parameter setting of a unit and to transfer it to other units of the same type.



The tank adjustment is not saved by the memory plug and it is not transferred. After replacement of the unit it has to be carried out manually.

10.3 Parameter setting during operation

- ▶ Make sure that the sensor is connected to an IO-Link-capable module (master) (→ 6.6).
- ▶ Read the sensor using a suitable IO-Link software → observe the operating instructions of the respective software.
- ▶ Set the parameters, adjustable parameters (→ 10.4).
- ▶ Check if the parameter setting was accepted by the unit. If necessary, read sensor again.
- ▶ Check whether the unit operates correctly.

10.4 Adjustable parameters

LEnG *)	Input of the probe length: Setting range: 100... 2000 mm / 4.0...78.8 inch. Determination of the probe length: (→ 7.3.2) After changing the probe length, a tank adjustment already made is deleted.
---------	---

MEdI *)	<p>Medium selection:</p> <p>[HIGH] = For water and water-based media. Operating mode is optimised for suppression of deposits on the probe.</p> <p>[Mid] = For water-based media and media with a medium dielectric constant value, e.g. oil-in-water emulsions. Operating mode optimised for the detection of media with increased foam build-up.</p>
tREF	<p>Carry out a tank adjustment (button [tREF Emty] or [tREF FLnG]):</p> <p>[tREF Emty] = adjustment of the complete probe (recommended)</p> <p>[tREF FLnG] = adjustment of the upper 50 mm from the lower edge of the process connection.</p> <p>Observe the notes on tank adjustment (→ 7.1.7).</p>
ou1...ou4	<p>Output configuration for the switching outputs OUT1...OUT4:</p> <p>[Hno] = hysteresis function/NO</p> <p>[Hnc] = hysteresis function/NC</p> <p>[Fno] = window function/NO</p> <p>[Fnc] = window function/NC</p> <p>[OFF] = output OFF (of high impedance)</p>
SP_FH1...4	<p>Set points 1...4 / upper limit for window function:</p> <p>Setting range: 15...L-30 mm / 0,6...L-1,2 inch</p>
rP_FL1...4	<p>Reset points 1...4 / lower limit for window function:</p> <p>Setting range: 10... L-35 mm / 0,4...L-1,4 inch</p>
dS1...4	Switch-on delay**) for OUT1...OUT4. Setting range 0.0...60.0 s
dr1...4	Switch-off delay**) for OUT1...OUT4. Setting range 0.0...60.0 s
uni	Unit of measurement; mm or inch
FOU1...4	<p>Response of OUT1...OUT4 in case of a fault:</p> <p>[On] = output switches ON in case of a fault</p> <p>[OFF] = output switches OFF in case of a fault</p> <p>Note: The IO-Link process value reacts according to the setting FOU1. In addition the process value is set to "invalid" (→ 11.3).</p>
dFo	<p>Delay time of the outputs for the state defined with [FOU2]; only effective in case of a fault.</p> <p>Note: The delay time also has effect on the IO-Link process value in case of a fault.</p>
P-n	<p>Output polarity for the switching output:</p> <p>[PnP] = output is positive switching</p> <p>[nPn] = output is negative switching</p>

*) Basic settings

**) Response according to VDMA. According to VDMA the switch-on delay always has an effect on SP, the switch-off delay always on rP irrespective of whether the normally open or normally closed function is used.

11 Operation

11.1 Single probe

The unit is intended for operation with a single probe.



A coaxial probe **cannot** be used with this unit.

The single probe is made up of one individual rod. Operation with a single probe is suited for the detection of aqueous media, in particular of heavily soiled aqueous media.



For correct function, the unit needs a sufficiently large metal launching surface / launching plate. It is necessary for transferring the microwave pulse to the tank with optimum transmission power.

For installation in closed metal tanks / metal bypass pipes, the tank lid / upper pipe section serves as a launching surface. For installation in open metal tanks, tanks made of plastic or metal tanks with plastic lids a sufficiently large fixing plate, a metal plate or similar must be used (→ 7.4.3) and (→ 7.4.4).

For operation with single probe, minimum distances to tank walls and structures in the tank must be adhered to (→ 7.1).

11.2 Function check

After power-on the device is in the operating mode. It carries out its measurement and evaluation functions and generates output signals according to the set parameters.

► Check whether the unit operates correctly.

11.3 Operating and diagnostic messages via IO-Link

IODD and IODD descriptive text as a pdf file at: www.ifm.com

11.4 Output response in different operating states

	OUT1...OUT4
Initialisation	OFF
Normal operation	according to the level and setting [oux] OFF or ON
Fault	OFF for [FOUx] = [OFF] ON for [FOUx] = [On]

12 Technical data and scale drawing



Technical data sheet and scale drawing at www.ifm.com.

13 Maintenance / transport

- ▶ Keep the process connection free of deposits and foreign bodies.

In case of heavy soiling:

- ▶ clean the process connection and the probe at regular intervals.

In case of longer operation separation layers can form in the medium (e.g. oil on water). This applies especially to still pipes or bypasses:

- ▶ Remove separation layers at regular intervals.



When the medium is changed, it may also be necessary to adapt the unit settings (→ 10.4).



Only if data storage is required in an IO-Link application:

The tank adjustment is not saved via IO-Link. After a replacement it must be carried out again (→ 10).

More information about data storage: (→ 15.1)

- ▶ It is not possible to repair the unit.
- ▶ After use dispose of the unit in an environmentally friendly way in accordance with the applicable national regulations.
- ▶ In case of returns ensure that the unit is free from soiling, especially dangerous and toxic substances.
- ▶ For transport only use appropriate packaging to avoid damage of the unit.

14 Factory setting

(special units LXxxxx*) are not taken into account)

	Factory setting	User setting
LEnG	3,94	
MEdI	HIGH	
tREF Emty	--	
tREF FlnG	--	
SP_FH1	25 % VMR**)	
rP_FL1	0.2 inch below SP_FH1	
SP_FH2	50 % VMR**)	
rP_FL2	0.2 inch below SP_FH2	
SP_FH3	75 % VMR**)	
rP_FL3	0.2 inch below SP_FH3	
SP_FH4	100 % VMR*)	
rP_FL4	0.2 inch below SP_FH4	
ou1...ou3	Hno	
ou4	Hnc	
dS1...dS4	0.0	
dr1...dr4	0.0	
uni	inch	
FOU1...FOU4	OFF	
dFo	0.0	
P-n	PnP	

*) Settings of the special units LXxxxx → Technical data sheet

**) VMR = final value of the measuring range = LEnG value minus 1.2 (in inch).
When the LEnG value is entered, the unit calculates the basic setting.

15 Notes on parameter setting via IO-Link



On delivery the unit is not operational.

During set-up, valid basic settings have to be sent to the device once even if the default settings correspond to the connected device. For parameter setting:
(→ 10)



Only if data storage is required in an IO-Link application:

The tank adjustment is not saved via IO-Link. After a replacement it must be carried out again (→ 10.4).



After a factory reset (button [Restore Factory Settings]), the device reboots and the factory settings are restored.

15.1 Unit locking / data storage (as from IO-Link V1.1)

The IO-Link master stores all parameters of the connected sensor (except tank adjustment, see above) if configured in the master (data storage). When a sensor is replaced by a sensor of the same type, the parameters of the old sensor are automatically written to the new sensor if configured in the master and if the new sensor has the factory settings.

For safety reasons the parameter download can be refused by the sensor.

Factory setting: [Open]

Data storage	- [Open] = unit allows parameter download from the master - [Locked] = unit refuses parameter download from the master
--------------	---

More information at www.ifm.com