

Original operating instructions
Fail-safe inductive sensor
GG851S

UK

11491853 / 00 11 / 2022

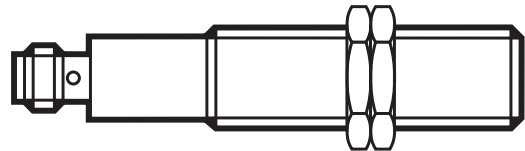

Contents

1	Preliminary note.....	3
1.1	Symbols used	3
1.2	Warning signs used	3
2	Safety instructions	4
2.1	Safety-related requirements regarding the application.....	4
3	Items supplied.....	5
4	Functions and features	6
5	Function	6
5.1	Enable zone.....	6
6	Installation.....	7
7	Electrical connection.....	8
8	Operation	9
8.1	Switching state of the outputs.....	9
8.1.1	The safe state	9
8.1.2	The switched state.....	9
8.1.3	Output characteristics.....	9
8.1.4	Cross fault / short circuit	9
8.2	Response times	10
8.3	LED display	11
9	Technical data.....	12
10	Troubleshooting	14
11	Maintenance, repair and disposal	14
12	Terms and abbreviations.....	15

1 Preliminary note

The instructions are part of the unit. They are intended for authorised persons according to the EMC and Low Voltage and Machinery Directives and safety regulations.

The instructions contain information about the correct handling of the product. Read the instructions before use to familiarise yourself with operating conditions, installation and operation.

Follow the safety instructions.

1.1 Symbols used

▶ Instructions

→ Cross-reference



Important note

Non-compliance can result in malfunction or interference.



Information

Supplementary note.

● LED on

○ LED off

⊗ LED flashes (2 Hz)

⊛ LED flashes quickly (5 Hz)

1.2 Warning signs used

WARNING

Warning of serious personal injury.

Death or serious irreversible injuries may result.

2 Safety instructions

- Follow the operating instructions.
- Improper use may result in malfunctions of the unit. This can lead to personal injury and/or damage to property during operation of the machine. For this reason note all remarks on installation and handling given in this document. Also adhere to the safety instructions for the operation of the whole installation.
- In case of non-observance of notes or standards, especially when tampering with and/or modifying the unit, any liability and warranty is excluded.
- If the sensor is damaged, the safety function cannot be guaranteed.
- Errors caused by damage cannot be detected by the sensor.
- The unit must be installed, connected and put into operation by a qualified electrician trained in safety technology.
- The applicable technical standards for the corresponding application must be complied with.
- For installation the requirements according to EN 60204 must be observed.
- In case of malfunction of the unit please contact the manufacturer. Tampering with the unit is not allowed.
- Disconnect the unit externally before handling it. Also disconnect any independently supplied relay load circuits.
- After installation, maintenance or repair of the system perform a complete function check.
- Use the unit only in specified environmental conditions (→ 9 Technical data). In case of special operating conditions please contact the manufacturer.
- Use only as described below (→ 4).

2.1 Safety-related requirements regarding the application

It must be ensured that the safety requirements of the respective application correspond to the requirements stated in these instructions.

! WARNING

Failure of the safety function

When used outside of the defined environmental conditions, the safety-related function of the sensor cannot be guaranteed.

- ▶ Use only in accordance with the defined environmental conditions (→ 9 Technical data).

Use of the sensor in the vicinity of chemical and biological media (solid, liquid, gaseous) as well as ionising radiation is not permitted.

Observe the following requirements:

- ▶ Take appropriate measures for a permanent and safe fixing (→ 6 Installation).
- ▶ In case of lateral damping in the area of the safe switch-off distance of < 5 mm, the target must stay there until the safe state of the complete system is achieved. Note the response time for safety-related faults of the sensor!
- ▶ The safe fixing must be regularly maintained at suitable intervals (cyclical inspection). Document maintenance actions (time, persons etc.).
- ▶ Adhere to EN 14119 for interlocking devices associated with guards.
- ▶ Adhere to the principle of normally closed operation for all external safety circuits connected to the system.
- ▶ In case of faults within the fail-safe sensor which result in the defined safe state: take measures to maintain the safe state when the complete control system continues to be operated.
- ▶ Replace damaged units.

3 Items supplied

1 fail-safe sensor GG851S with 2 lock washers and 2 M18 fixing nuts,
1 original operating instructions GG851S, ident no. 11491853.

If one of the above-mentioned components is missing or damaged, please contact one of the ifm branch offices.

4 Functions and features

The fail-safe inductive sensor GG851S detects metal without contact.

Safety function SF: the safe state (output stage switched off; logic "0") is achieved when damping smaller than the safe switch-off distance (→ 9 Technical data).

Also observe the notes on installation of the sensor (→ 6 Installation).

The fail-safe inductive sensor is a proximity device with defined behaviour under fault conditions (PDDDB) to IEC 60947-5-3.

The fail-safe sensor conforms to Performance Level d according to EN ISO 13849-1 as well as to the requirements SIL 2 to IEC 61508 and meets SILcl 2 to IEC 62061.

The unit corresponds to the classification I1A18SP2 to IEC 60947-5-2 for flush installation (→ 6 Installation).

The fail-safe inductive sensor has been certified by TÜV Nord.

5 Function

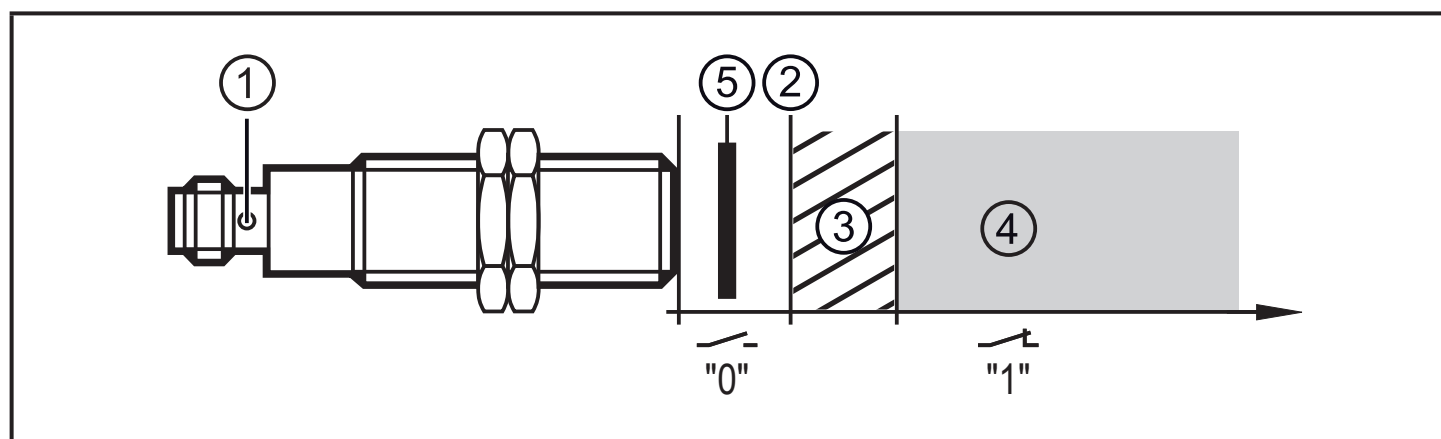

1: dual LED: signal (yellow); power (green)

2: safe switch-off distance

3: inadmissible zone

4: enable zone

5: target

5.1 Enable zone

The outputs (OSSDs) are only enabled when undamping in the enable zone > 10 mm. The change of switching states of the OSSDs is carried out in the inadmissible zone (3). Below the safe switch-off distance the sensor is damped and the outputs (OSSDs) are switched off.

- ▶ Take measures to ensure that the damping element does not remain in the inadmissible zone.

If damped with a reference target of 24 x 24 x 1 mm made of FE360 and flush installation to IEC 60947-5-2, the safe switch-off distance is < 5 mm.

 The safe switch-off distance is different if damping elements which deviate from the reference target in terms of material, form and size are used.

 Recommendation: Set the demand upon the safety function to half the safe switch-off distance.

UK

6 Installation

The sensor can be mounted **flush** according to IEC 60947-5-2, type I1A18SP2.

 **Ensure the unit cannot work loose by using the supplied lock washers:**

- ▶ Use the supplied lock washers and tighten the fixing nut with 15...25 Nm.

 Do not use the supplied lock washers and nuts for softer materials (e.g. aluminium, plastics, wood).

Secure fixing is only assured with a carrier material hardness of 230...350 HV (table ISO 18265, Vickers hardness ISO 898-1).

 ▶ Verify the safe fixing:

1. Loosen the fixing nut.
 - > The lock washer must not rotate simultaneously.
 - > The torque for opening the connection must be greater than the tightening torque.
 - > Lock washer marks must be clearly visible in the carrier material.
2. Tighten the fixing nut with 15...25 Nm.

 No mechanical forces may be exerted. Forces required for safe fixing are exempt from this.

- ▶ Adhere to the installation conditions in accordance with the figures 1 to 3:

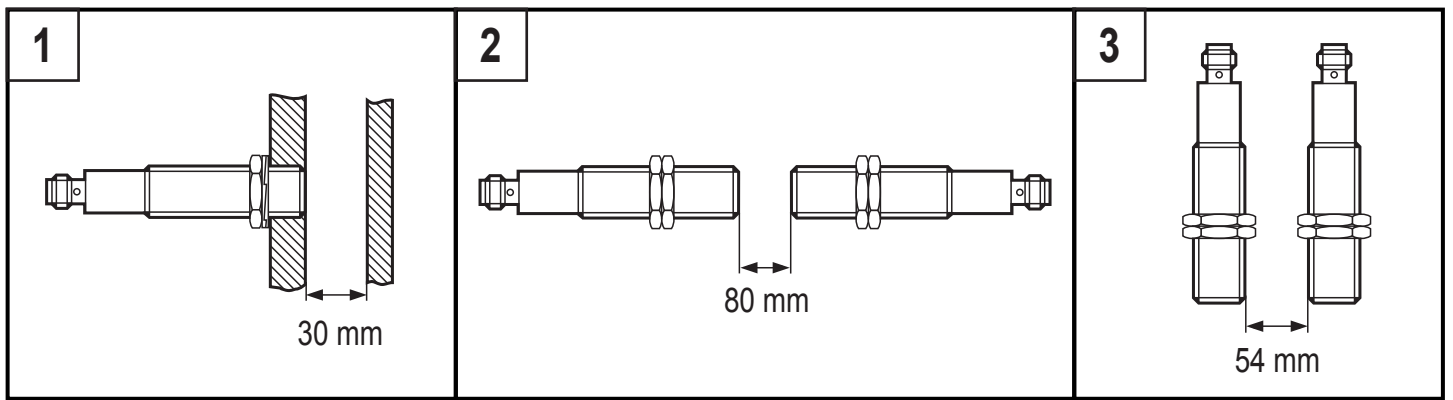

- ▶ Tighten the socket according to the manufacturer's indications. Observe the tightening torque for the ifm socket (e.g. EVxxxx: 0.6...1.5 Nm).

7 Electrical connection

- ▶ Disconnect power. Also disconnect any independently supplied relay load circuits.



The sensor can be damaged if energized during connection.

- ▶ Supply voltage: connect L+ to pin 1 and L- to pin 3 of the connector.



The nominal voltage is 24 V DC. This voltage may vary between 19.2 V and 30 V incl. 5 % residual ripple to EN 61131-2.



In case of a single fault the supply voltage must not exceed a maximum of 40 V DC. (This requires the safe separation between power supply and transformer.)

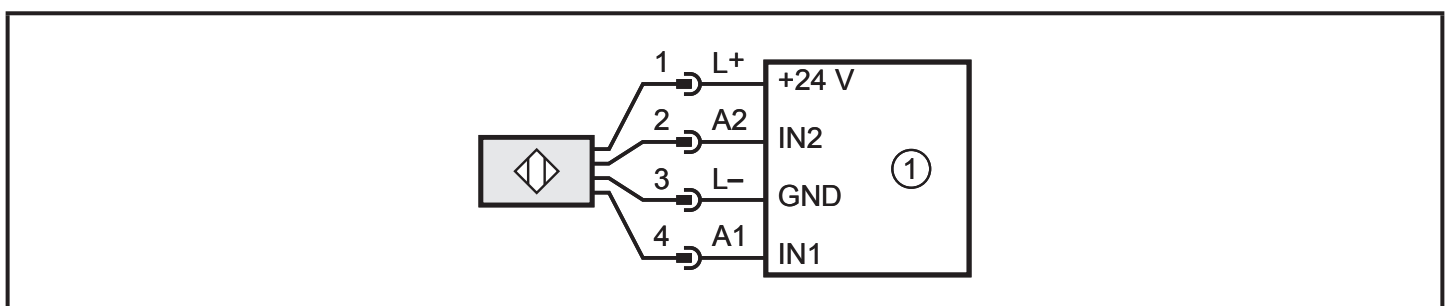

1: safety-related logic unit

* When there is no current flow on the output stage, back feeding > 3.5 V will lead to malfunction.

8 Operation

8.1 Switching state of the outputs

8.1.1 The safe state

The safe state is when at least one of the outputs A1 or A2 (OSSDs) is switched off (zero-current state: logic "0").

If one of the outputs A1 or A2 is switched off, the subsequent safety-related logic unit must bring the complete system into the state defined as safe.

8.1.2 The switched state

If the damping element is in the enable zone and if there is no sensor error, both outputs A1 and A2 (OSSDs) are enabled (logic "1").

8.1.3 Output characteristics

The output characteristics are compatible with the input characteristics to EN 61131-2 type 1 or 2:

Logic "1"	$\geq 15\text{ V}$	2...15 mA
	$\geq 11\text{ V}$	15...30 mA
Logic "0"	$\leq 5\text{ V}$	leakage current 0.2 mA

The interface corresponds to interface type C class 1 according to the ZVEI position paper "Klassifizierung binärer 24-V-Schnittstellen mit Testung im Bereich der Funktionalen Sicherheit" (Classification of binary 24V interfaces tested with regard to functional safety).

8.1.4 Cross fault / short circuit

- A cross fault between both outputs (A1 and A2) is detected by the fail-safe sensor and results in the outputs (OSSD) being switched off at the next safety request. The outputs A1 and A2 remain switched off until the error has been removed or a voltage reset has been carried out.
- A cross fault (short circuit) between output A2 and the supply voltage results in the other output A1 being switched off in case of a safety request.
- The subsequent safety-related logic unit (e.g. safe PLC or safety relay) must be able to detect faults via dual-channel evaluation (e.g. "stuck-at faults"). The monitored hazardous area may only be enabled if both inputs of the safety-related logic unit were previously switched off at the same time (logic "0").
- When there is no current flow on the output stage, back feeding $> 3.5\text{ V}$ will lead to malfunction.

8.2 Response times

Response time on safety request (removal from the enable zone)	≤ 5 ms
Response time when approaching the enable zone (enable time)	≤ 5 ms
Risk time / response time for safety-related faults	≤ 45 ms
Simultaneity of switching on and off of the outputs in case of a safety request	≤ 1 ms
Duration of switch-off test pulses on output A2	≤ 1 ms

8.3 LED display

LED	Operating status	Outputs	A1 (OSSD)	A2 (OSSD)
○ Signal ○ Power	No voltage supply	Both outputs switched off	0	0
○ Signal ⊗ Power	Undervoltage		1 0	0 0
○ Signal ⊗ Power	Overvoltage	Both outputs switched off	0	0
	Sensor fault (→ 10 Troubleshooting)	One output or both outputs switched off	0 1 0	1 0 0
○ Signal ● Power	damping element is at safe switch-off distance from the sensor (< 5 mm)	Both outputs switched off	0	0
● Signal ● Power	damping element is in the enable zone (> 10 mm)	Both outputs enabled	1	1

UK

9 Technical data

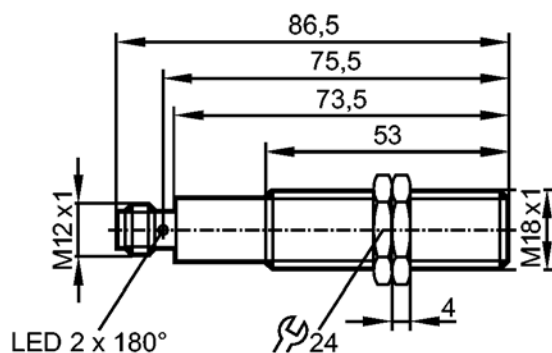

Product characteristics

Fail-safe inductive sensor

Metal thread

M12 connector

Enable zone > 10 mm; [f] flush mountable

Complies with the requirements:

EN ISO 13849-1: 2015 category 2 PL d

IEC 61508: SIL 2

IEC 62061: SILcl 2

Application

Type of operation

continuous operation (maintenance-free)

Electrical data

Electrical design

DC PNP

Operating voltage [V]

24 DC (10...30 DC)

Rated insulation voltage [V]

30

Current consumption [mA]

< 30

Protection class

III

Reverse polarity protection

yes

Outputs

Output function

2 x OSSD (A1 and A2)

Output data

Interface type C class 1

Output voltage at 24 V

compatible with EN 61131-2 inputs type 1, 2

Voltage drop [V]

< 2.5; (30 mA)

Minimum load current [mA]

2

Current rating [mA]

50

Short-circuit protection

yes

Max. capacitive load CL_max [nF]

20

Range

Enable zone [mm]

> 10

Safe switching off distance s(ar) [mm]

< 5

Reaction times

Power-on delay time [s]

1

Response time to safety request [ms]

≤ 5

Response time when approaching [ms]
the enable zone (enable time)

≤ 5

Risk time (response time for safety [ms]-related faults)	≤ 45
--	------

Environment	
Applications	Class C to EN 60654-1 weatherproof application
Ambient temperature [°C]	-25...70, for service life ≤ 87600 h 10...40, for service life ≤ 175200 h
Rate of temperature change [K/min]	0.5
Max. relative air humidity [%]	5...95, briefly 5...70, permanently
Air pressure [kPa]	80...106
Height above sea level [m]	≤ 2000
Ionising radiation	not permissible
Salt spray	Tested to IEC 60068-2-11
Protection	IP 65 / IP 67

Tests / approvals		
EMC	IEC 60947-5-2	
	IEC 60947-5-3	
	EN 60947-5-2	
	EN 61000-4-2 ESD:	6 kV CD / 8 kV AD
	EN 61000-4-3 HF radiated:	20 V/m
	EN 61000-4-4 Burst:	2 kV
	EN 61000-4-6 HF conducted:	10 V
	EN 61000-4-8:	30 A/m
EN 55011:	class B	
Shock resistance	IEC 60947-5-2	
Vibration resistance	IEC 60947-5-2	



Safety classification	
Mission time TM [h]	≤ 175200, (20 years)
Safety-related reliability PFHd [1/h]	< 1.0E-07

Mechanical data	
Mounting	flush mountable
Housing materials	Brass white bronze coated; PBT
Weight [kg]	0.15

Displays / operating elements	
Display	LED yellow (signal), LED green (power)

Electrical connection	
Connection	M12 connector; Gold-plated contacts

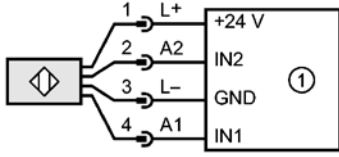
Wiring

1: Safety-related logic unit

Accessories	
Accessories (included)	2 lock nuts

UK

Remarks

Remarks

Unless stated otherwise, all data refer to the 24x24x1 mm reference target plate to IEC 60947-5-2 (FE360 = mild steel) over the whole temperature range.

Pack quantity

[piece]

1

ifm electronic gmbh • Friedrichstraße 1 • 45128 Essen — GB — GG851S-04 — 31.05.2016

10 Troubleshooting

LED display → 8.3

Problem	Possible cause	Troubleshooting
No LED display	No voltage supply	Apply voltage
Power LED flashes and sensor does not switch	<ul style="list-style-type: none"> • Undervoltage • Overvoltage 	Correct the voltage (→ 9 Technical data)
Sensor does not switch, not even after undamping and redamping	<p>Sensor was brought into the safe state (logic "0"). Cause:</p> <ul style="list-style-type: none"> • cross fault between both outputs A1 and A2 • cross fault between one output (A1 or A2) and the supply voltage • error in the sensor detected 	<ul style="list-style-type: none"> • Remove the cross fault • Replace the unit

11 Maintenance, repair and disposal

If used correctly, no maintenance and repair measures are necessary.

Only the manufacturer is allowed to repair the unit.

After use dispose of the unit in an environmentally friendly way in accordance with the applicable national regulations.

12 Terms and abbreviations

OSSD	Output Signal Switch Device	
PDDDB	Proximity devices with defined behaviour under fault conditions	
PFH (PFH _D)	Probability of (dangerous) Failure per Hour	
PL	Performance Level	PL to EN ISO 13849-1
SIL	Safety Integrity Level	SIL 1-4 to IEC 61508. The higher the SIL, the lower the probability that a safety function will fail.
SIL _{cl}	Safety Integrity Level _{claim limit}	According to IEC 62061
T _M	Mission time	Lifetime to EN 60947-5-3 (= max. service life)

UK