



Operating instructions  
Electronic pressure sensor  
with integrated temperature sensor

GB

**PL15**

11384739 / 01 05 / 2023

## Contents

1	Preliminary note	4
1.1	Symbols used	4
2	Safety instructions	5
3	Intended use	6
3.1	Application area	6
4	Function	7
4.1	IO-Link	7
4.2	IO-Link functions of the sensor	7
4.2.1	Internal unit temperature	7
4.2.2	Counter overpressure events	7
4.2.3	Counter overtemperature events	8
4.2.4	Optical localisation	8
4.2.5	Event logging	8
4.2.6	Operating hours counter	8
4.2.7	Defined state in case of a fault	8
4.3	Operating modes	8
4.3.1	2-wire operation	8
4.3.2	3-wire operation	8
5	Installation	9
5.1	Sealing versions	9
5.1.1	Flush mount zero-leak using metal-to-metal seal	9
5.1.2	Sealing flush mount via sealing ring	11
5.1.3	Rear sealing via sealing ring	12
6	Electrical connection	14
7	Parameter setting	15
7.1	Parameter setting via PC	15
7.2	Parameter setting via the memory plug	15
7.3	Scale analogue value	16
7.3.1	Manually scale analogue value	16
7.3.2	Scaling the analogue value using the teach function	16
7.4	Select the standard unit of measurement (option)	16
7.5	Standard unit of measurement for medium temperature	16
7.6	Setting of the output function	16
7.7	User settings (optional)	16
7.7.1	Define the status of output 2 in case of a fault	16
7.7.2	Set damping for the analogue output	17
7.7.3	Damping for the process data flow	17
7.8	Zero-point calibration	17
7.9	Diagnostic functions	17
7.9.1	Read min/max values for the system pressure	17
7.9.2	Read min/max values for the medium temperature	18
7.9.3	Read number of times the pressure limit is exceeded	18
7.9.4	Read number of times the temperature limit is exceeded	18
7.9.5	Event logging	18
7.10	Reset sensor / parameter	18
7.11	Simulation	19
7.11.1	Set simulation value pressure	19
7.11.2	Set simulation value temperature	19
7.11.3	Set simulation duration	19
7.11.4	Switch simulation on / off	19
7.12	List of the parameters	19
7.13	List of system commands	20
8	Operation	22
9	Troubleshooting	23
10	Disposal, repair and return	24



---

11 Factory setting ..... 25

# 1 Preliminary note

You will find instructions, technical data, approvals and further information using the QR code on the unit / packaging or at [www.ifm.com](http://www.ifm.com).

## 1.1 Symbols used

- ✓ Requirement
- ▶ Instructions
- ▷ Reaction, result
- [...] Designation of keys, buttons or indications
- Cross-reference
-  Important note  
Non-compliance may result in malfunction or interference.
-  Information  
Supplementary note

## 2 Safety instructions

- The unit described is a subcomponent for integration into a system.
  - The system architect is responsible for the safety of the system.
  - The system architect undertakes to perform a risk assessment and to create documentation in accordance with legal and normative requirements to be provided to the operator and user of the system. This documentation must contain all necessary information and safety instructions for the operator, the user and, if applicable, for any service personnel authorised by the architect of the system.
- Read this document before setting up the product and keep it during the entire service life.
- The product must be suitable for the corresponding applications and environmental conditions without any restrictions.
- Only use the product for its intended purpose (→ Intended use).
- If the operating instructions or the technical data are not adhered to, personal injury and/or damage to property may occur.
- The manufacturer assumes no liability or warranty for any consequences caused by tampering with the product or incorrect use by the operator.
- Installation, electrical connection, set-up, operation and maintenance of the product must be carried out by qualified personnel authorised by the machine operator.
- Protect units and cables against damage.
- Only use the product for permissible media (→ Technical data).

## 3 Intended use

The unit measures and monitors the system pressure and the medium temperature of machines and installations.

### 3.1 Application area

Type of pressure: relative pressure



Information on pressure rating and bursting pressure → Data sheet



Avoid static and dynamic overpressure exceeding the indicated pressure rating by taking appropriate measures. The indicated bursting pressure must not be exceeded. Even if the bursting pressure is exceeded only for a short time, the unit may be destroyed. ATTENTION: Risk of injury!



The units are vacuum resistant.

## 4 Function

Measuring cell:

- The system pressure is measured by a ceramic capacitive measuring system.
- The medium temperature is recorded on the back of the ceramic measuring cell.

Signal transmission:

- The sensor can be operated conventionally with digital and analogue outputs (SIO mode) and in IO-Link mode.

SIO mode:

- Analogue signal measured pressure value 4-20 mA (pin 2).

IO-Link mode:

- Measured pressure value
- Measured temperature value
- Exceeding or falling below the limits of the measuring range
- Device status
- Parameter setting
- Device diagnostics (events)

### 4.1 IO-Link

IO-Link is an internationally standardised IO technology (IEC 61131-9) for communicating with sensors and actuators.



Further information about IO-Link at: [www.io-link.com](http://www.io-link.com)

IO-Link offers the following advantages:

- Noise-immune transmission of several process values.
- Parameter setting during operation as well as point-to-point at the desk.
- Device diagnostics (events)
- Data storage: Automatic new parameter setting in case of replacement.
- Detection of connected units.
- Freely definable parameters to identify the units in the plant.



Information and documentation on the IO-Link interface at: [www.io-link.ifm](http://www.io-link.ifm)

### 4.2 IO-Link functions of the sensor

#### 4.2.1 Internal unit temperature

The internal unit temperature of the sensor can be read out.

#### 4.2.2 Counter overpressure events

The unit has a counter for overpressure events = [HIPC]. The value above which a pressure is considered to be overpressure can be set.

### 4.2.3 Counter overtemperature events

The unit has a counter for overtemperature events = [HITC]. The value above which a temperature is considered to be overtemperature can be set.

### 4.2.4 Optical localisation

The sensor can be localised in the plant via the commands [Flash\_On] / [Flash\_Off]. When using the command, the LED flashes.

### 4.2.5 Event logging

With IO-Link, the sensor has two logging mechanisms for IO-Link events:

- [Event History]: Listing of the last 20 events.
- [Event Counter]: Counting of all events that have occurred.

### 4.2.6 Operating hours counter

In the parameter [operating\_hours], the hours are counted during which the sensor was active (cannot be reset).



In case of a voltage interruption, the counter events of less than one hour can be lost.

### 4.2.7 Defined state in case of a fault

If a device fault is detected, the analogue output goes into a defined state, which is defined via the parameter [FOU2].

## 4.3 Operating modes

The operating mode is defined by the wiring (→ Electrical connection) and automatically recognised by the unit.

### 4.3.1 2-wire operation

OUT2 (pin 2)	Analogue signal proportional to pressure 4...20 mA
--------------	--

### 4.3.2 3-wire operation

OUT1 (pin 4)	Communication via IO-Link
OUT2 (pin 2)	Analogue signal proportional to pressure 4...20 mA



## 5 Installation



Before installing and removing the device: make sure that no pressure is applied to the system.



Accessories welding adapter (order no.: E30509) and welding aid (order no.: E43440) at: [www.ifm.com](http://www.ifm.com)



The sealing of the ceramic measuring cell is free of elastomers and thus maintenance-free.



Only remove the device from the packaging and remove the protective cap immediately before installation.

▶ Check the device for damage.

▷ Do not use a damaged device.

### 5.1 Sealing versions

The unit can be sealed to the process in three ways:

Flush mount zero-leak using metal-to-metal seal (→ [9](#))

Sealing flush mount via sealing ring (→ [11](#))

Rear sealing via sealing ring (→ [12](#))

#### 5.1.1 Flush mount zero-leak using metal-to-metal seal

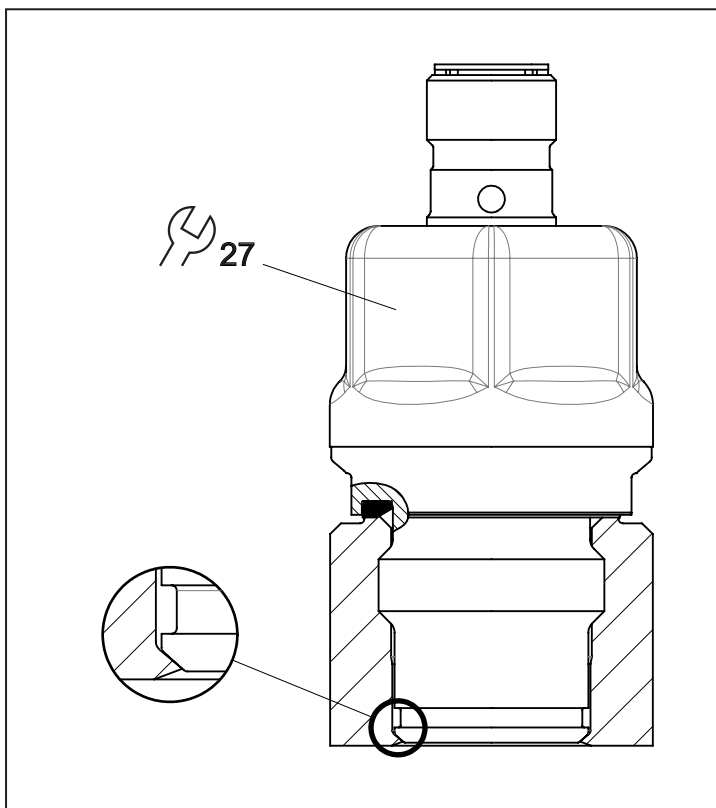

▶ Ensure cleanliness of the sealing areas.

▶ Lightly grease the contact areas using a suitable lubricating paste which has been approved for this application.

▶ Insert the sensor into the adapter or into a suitable threaded hole (→ Scale drawing threaded hole).

► Tighten firmly. Tightening torque: 25 Nm.



Repeated screwing and unscrewing of the sensor can impair the sealing effect.

**Use of welding adapters:**



When using a welding adapter, observe the permissible pressure rating of the adapter.

► During the welding process, make sure that the adapter is not deformed and that the sealing area is not affected.

► Use welding aid E43440 for optimum heat conduction.

► Observe the instructions and data sheet of the adapter used.



When reworking the weld seam:

► leave out or protect the sealing area.

**Threaded hole for metal-to-metal sealing:**

Scale drawing to create a suitable threaded hole for flush metal-to-metal sealing of the sensor.

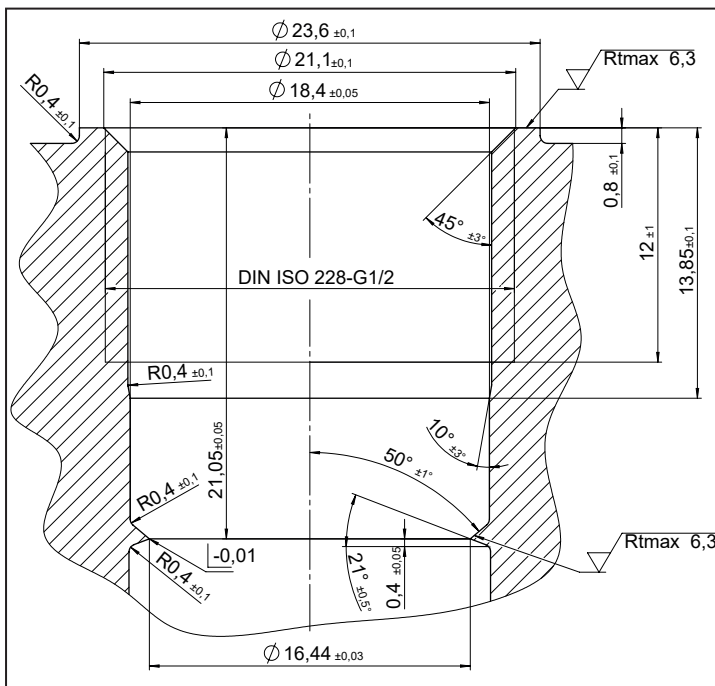

### 5.1.2 Sealing flush mount via sealing ring

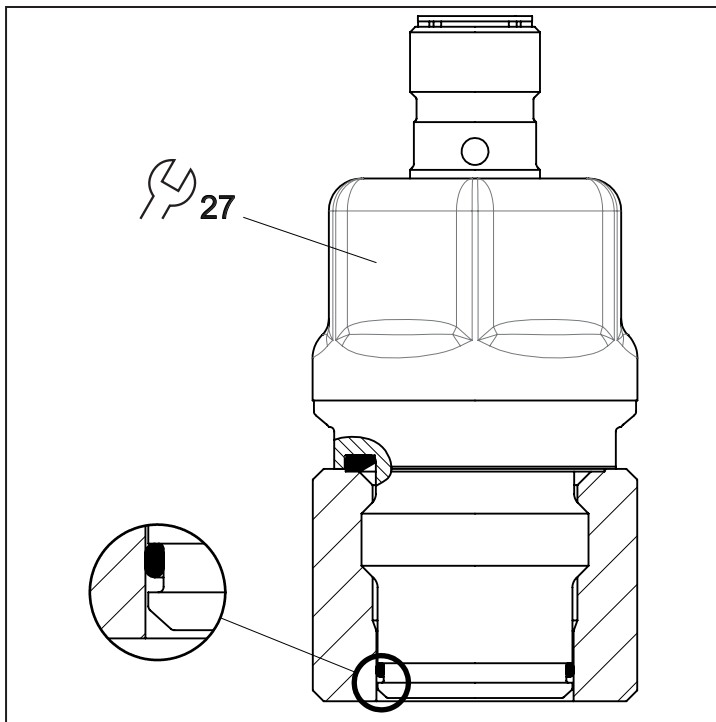

**!** This sealing version is only possible up to a nominal pressure range of 60 bar.

**i** The sealing ring is not supplied with the device. Accessories sealing ring FKM (order no.: E30510), FFKM (order no.: E30512), EPDM (order no.: E30511) at: [www.ifm.com](http://www.ifm.com)

- ▶ Lightly grease the contact areas using a suitable lubricating paste which has been approved for this application.
- ▶ Insert the sensor into the adapter or into a suitable threaded hole (→ Scale drawing threaded hole).
- ▶ Observe surface and shape tolerances.
- ▶ Ensure cleanliness of the sealing areas.
- ▶ Tighten firmly. Tightening torque: 25 Nm.

#### Threaded hole for sealing via sealing ring:

Scale drawing to create a suitable threaded hole for flush mount sealing of the sensor by its sealing ring.

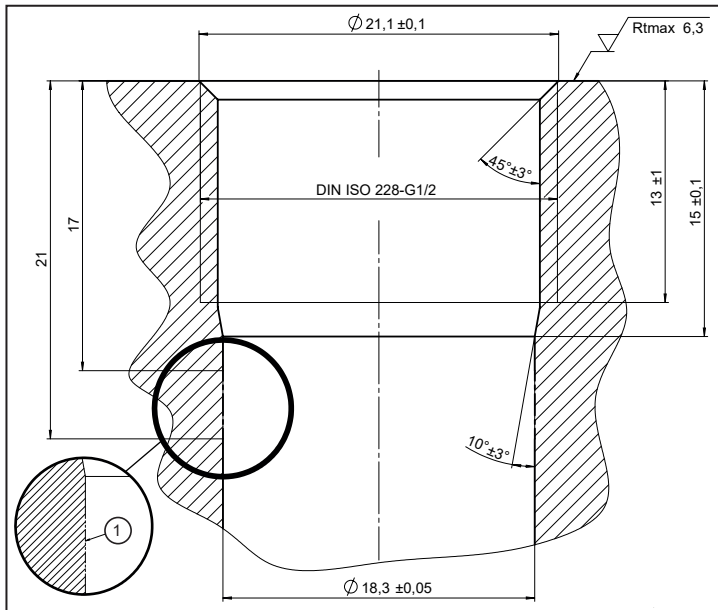

1:  $R_{tmax} 6.3$  must be guaranteed in this area, as the sealing ring is located here!

### 5.1.3 Rear sealing via sealing ring

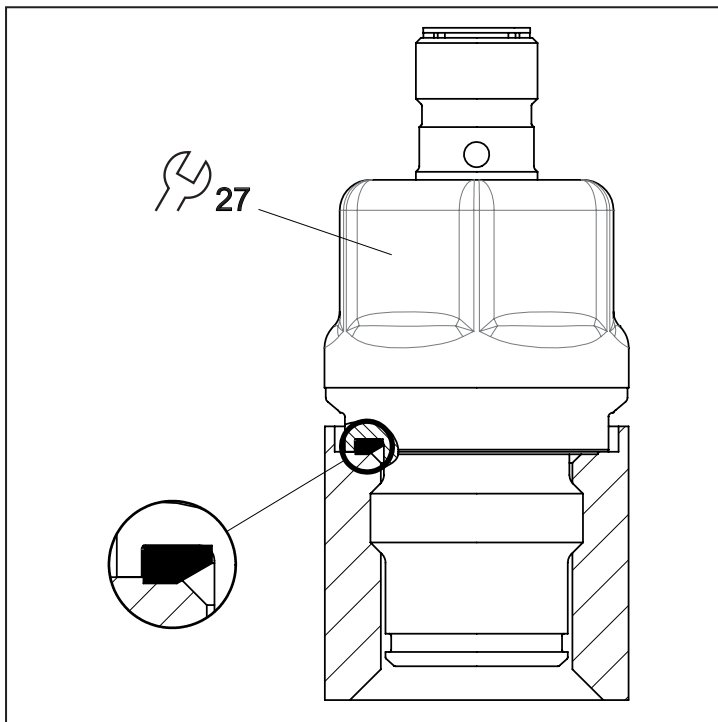

 The rear sealing ring made of FKM according to DIN EN ISO 1179-2 (order no.: E30492) has extended chemical resistance and is factory-mounted. Further moulded seals made of FFKM (order no.: E30513) and EPDM (order no.: E30451) are available as accessories.



Observe the following when sealing exclusively with the rear sealing ring (3):

- ▶ requirements for the screw-in hole: in accordance with DIN EN ISO 1179-1, observe the minimum insertion depth of 21.5 mm.
- ▶ The sealing area on the flange/socket must be flush and have a surface structure of at least  $Rz = 6.3$  (observe DIN EN ISO 1179-1).
- ▶ If required: lightly grease the contact areas using a suitable lubricating paste which has been approved for this application.
- ▶ Insert the sensor in a process connection G1/2.
- ▶ Tighten firmly. Tightening torque: 25 Nm.

## 6 Electrical connection



The unit must be connected by a qualified electrician.

The national and international regulations for the installation of electrical equipment must be adhered to.

Supply voltage SELV, PELV according to the technical data sheet.

- ▶ Disconnect power.
- ▶ Connect the unit as follows:

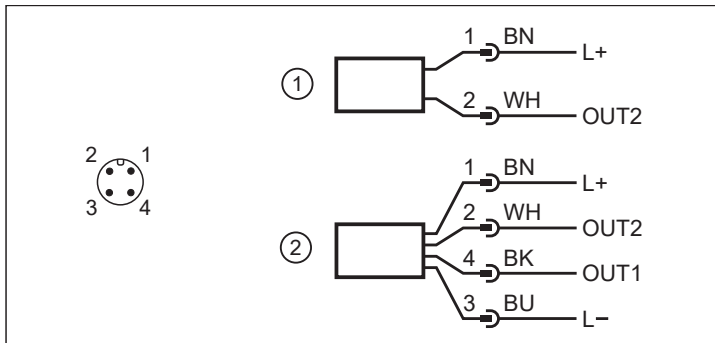

- 1: 2-wire operation (2w)
- 2: 3-wire operation (3w)

Pin	Core colour	
1:	BN	Brown
2:	WH	White
3:	BU	Blue
4:	BK	Black
OUT1: Communication via IO-Link		
OUT2: Analogue output		
Colours to DIN EN 60947-5-2		

### Circuit examples:

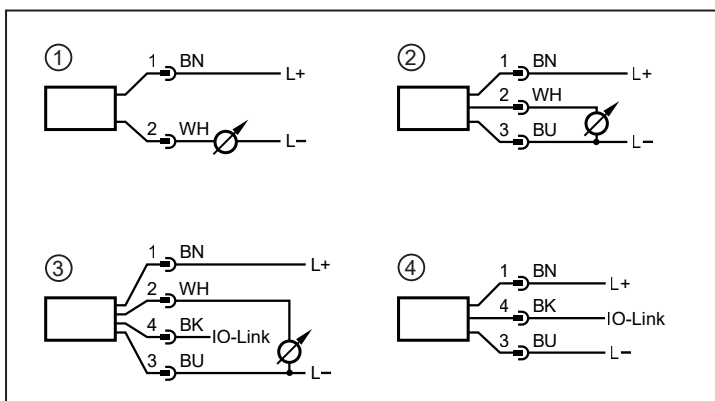

- 1: (2w) 1 x analogue
- 2: (3w) 1 x analogue
- 3: (3w) 1 x analogue / 1 x IO-Link
- 4: (3w) 1 x IO-Link

## 7 Parameter setting



The unit can be configured via the IO-Link function.

- ▶ Use the unit description file (IODD) for this purpose: [www.ifm.com](http://www.ifm.com)
- ▶ Prepare IO-Link hardware and software for parameter setting.
- ▶ Connect the unit with e.g. an IO-Link interface or programmed memory plug.
- ▶ Set the parameters.
- ▶ Put the unit into operation.
- ▶ The parameters can be set before installation or during operation.



Changing parameters during operation can influence the function of the plant.

- ▶ Make sure that there will be no malfunctions or dangerous operation in your plant.

### 7.1 Parameter setting via PC

For parameter setting, an IO-Link parameter setting software, an IO-Link master and a suitable device description file (IODD) are required. [www.ifm.com](http://www.ifm.com).

- ▶ Prepare computer, parameter setting software and IO-Link master.
- ▶ Connect the device with the IO-Link master.
- ▶ Follow the menu of the IO-Link parameter setting software.
- ▶ Set the parameters.
- ▶ Put the device into operation.

### 7.2 Parameter setting via the memory plug

A parameter set can be written to the device / can be recorded by the device via a memory plug (ifm storage module): [www.ifm.com](http://www.ifm.com).



In order to allow for data to be written from the memory plug to the sensor, the sensor must have the factory setting.



If the sensor has been configured, the memory plug records the parameter set which can then be transferred to other sensors of the same type.

- ▶ Load a suitable parameter set (e.g. from a PC or from a sensor of the same type) to the memory plug.
- ▶ Connect the memory plug between sensor and socket.
- ▷ Sensor with factory setting:  
When voltage is supplied, the parameter set is transferred from the memory plug to the sensor.
- ▷ Sensor with changed settings:  
When voltage is supplied, the memory plug records the sensor's parameter set.
- ▶ Remove the memory plug.
- ▶ Put the unit into operation.

More information on the memory plug: → Documentation [www.ifm.com](http://www.ifm.com).

## 7.3 Scale analogue value

### 7.3.1 Manually scale analogue value

<ul style="list-style-type: none"> <li>▶ Select [ASP2] and set the pressure value at which 4 mA is provided.</li> <li>▶ Select [AEP2] and set the pressure value at which 20 mA is provided.</li> </ul> <p>Minimum distance between ASP2 and AEP2 = 20 % of the measuring span (scaling factor 5).</p>	<p>[ASP2] [AEP2]</p>
--	--------------------------

### 7.3.2 Scaling the analogue value using the teach function

<ul style="list-style-type: none"> <li>▶ Approach the desired minimum system pressure in the installation and keep it constant.</li> <li>▶ Select [tASP].</li> <li>▷ The current pressure is defined as start value for the analogue signal (4 mA).</li> </ul>	[tASP]
<ul style="list-style-type: none"> <li>▶ Approach the desired maximum system pressure in the installation and keep it constant.</li> <li>▶ Select [tAEP].</li> <li>▷ The current pressure is defined as end value for the analogue signal (20 mA).</li> </ul>	[tAEP]

## 7.4 Select the standard unit of measurement (option)

<ul style="list-style-type: none"> <li>▶ Select [uni.P] and set the unit of measurement: [bAr] / [mbar] / [MPa] / [kPa] / [PSI]</li> </ul>	[uni.P]
--	---------



The selectable units of measurement depend on the respective unit. Changing the unit has no effect on the transmission of the IO-Link process value, which is always transmitted in PA.

## 7.5 Standard unit of measurement for medium temperature

<ul style="list-style-type: none"> <li>▶ Select [uni.T] and set the unit of measurement: [°C] / [°F]</li> </ul>	[uni.T]
---	---------



Changing the unit has no effect on the transmission of the IO-Link process value, which is always transmitted in °C.

## 7.6 Setting of the output function

<ul style="list-style-type: none"> <li>▶ Select [OU2] and set the output function: [I] = Pressure proportional analogue signal 4...20 mA [Off] = Output off.</li> </ul>	[OU2]
---	-------

## 7.7 User settings (optional)

### 7.7.1 Define the status of output 2 in case of a fault

<p>Define status of OUT2 in case of an internal fault:</p> <ul style="list-style-type: none"> <li>▶ Select [FOU2] and set the value: Off = Analogue signal goes to the lower final value (&lt; 3.6 mA) On = Analogue signal goes to the upper final value (&gt; 21 mA)</li> </ul>	[FOU2]
---	--------



In case of fault indication:

- ▶ Read parameters via IO-Link or contact the manufacturer.



## 7.7.2 Set damping for the analogue output

▶ Select [dAA] and set the damping constant in seconds (T value: 63%). Setting range: 0.00... 99.99 s	[dAA]
--	-------



Damping [dAA] only influences the analogue output / analogue signal path.

## 7.7.3 Damping for the process data flow

▶ Select [dAP.P] and set the damping constant in seconds (T value: 63%). Setting range: 0.00... 99.99 s	[dAP.P]
--	---------



Damping [dAP.P] influences the process data flow (IO-Link communication).

## 7.8 Zero-point calibration

Manual adjustment of the offset: ▶ Select [coF] and set the zero point between -5%...+5%. The internal measured value "0" is shifted by this value.	[coF]
---	-------

### Example: Change zero point [coF]

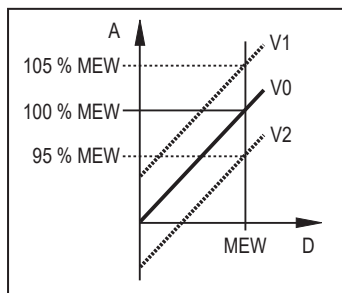

A: Output signal  
D: Pressure  
MEW: Final value of the measuring range  
V0: Curve of measured values at factory setting  
V1, V2: Changed curve of measured values

Automatic adjustment of the offset: ▶ Select [tcoF]. The internal measured value "0" is shifted by this value. Tech area: -5%...+5% of the measuring span.	[tcoF]
---	--------



[coF] and [tcoF] can be reset with the system command [RESET\_COF].

## 7.9 Diagnostic functions

### 7.9.1 Read min/max values for the system pressure

▶ Select [Hi.P] or [Lo.P] to display the highest or lowest measured process value: [Hi.P] = maximum value system pressure [Lo.P] = minimum value system pressure	[Hi.P] [Lo.P]
--	------------------



With the system command [RESET\_HI\_PRES], [Hi.P] can be reset.  
With the system command [RESET\_LO\_PRES], [Lo.P] can be reset.  
With the system command [RESET\_HI\_LO\_PRES], [Hi.P] and [Lo.P] can be reset.



### 7.9.2 Read min/max values for the medium temperature

▶ Select [Hi.T] or [Lo.T] to display the highest or lowest measured process value: [Hi.T] = max. value medium temperature [Lo.T] = min. value medium temperature	[Hi.T] [Lo.T]
--	------------------

-  With the system command [RESET\_HI\_TEMP], [Hi.T] can be reset.
- With the system command [RESET\_LO\_TEMP], [Lo.T] can be reset.
- With the system command [RESET\_HI\_LO\_TEMP], [Hi.T] and [Lo.T] can be reset.



### 7.9.3 Read number of times the pressure limit is exceeded

[HIPC]: Number of times the pressure limit is exceeded. HIPC counts how often the limit HIPS has been exceeded. The limit must be exceeded for at least 0.5 ms. [HIPS]: Setting of the threshold for the pressure limit counter.	[HIPC] [HIPS]
---	------------------

-  With the system command [RESET\_HIPC], [HIPC] can be reset.
-  In case of a voltage interruption, the counter events of the last 10 minutes can be lost.

### 7.9.4 Read number of times the temperature limit is exceeded

[HITC]: Number of times the temperature limit is exceeded. HITC counts how often the limit HITS has been exceeded. The limit must be exceeded for at least 0.5 ms. [HIPT]: Setting of the threshold for the temperature limit counter.	[HITC] [HITS]
---	------------------

-  With the system command [RESET\_HITC], [HITC] can be reset.
-  In case of a voltage interruption, the counter events of the last 10 minutes can be lost.

### 7.9.5 Event logging

With IO-Link, the sensor has two logging mechanisms:

- Event History (Parameter [Event\_History])
- Event Counter (Parameter [Event\_Counter])

The last 20 events that occurred are recorded in the event history. As long as no event has occurred, the value [noEvent] or [0] appears in this list.

The event counter (limited to Int32 events) can be used to read how often a specific event has occurred at the sensor.

The event counter and the event history can be reset using the system commands [RESET\_EVENT\_HISTROY], [RESET\_EVENT\_COUTER ].

-  In case of a voltage interruption, the events of the last 10 minutes can be lost.

### 7.10 Reset sensor / parameter

Application reset [APPL]: The application reset resets all application-specific parameters that can be set or taught. The device identification parameters Application Specific Tag, Function Tag and Location Tag are retained.	[APPL]
---	--------



If IO-Link data storage is activated, this triggers a parameter update in the master. This writes the parameters configured in the master to the unit again. An application reset may therefore be ineffective.

Back to Box [btb] The Back to Box Reset also resets all writeable unit identification parameters such as Application Specific Tag, Function Tag and Location Tag, as well as diagnosis and status parameters.	[btb]
--	-------



After the Back to box reset, the sensor suspends communication and measurement operation until the voltage is interrupted. The IO-Link data storage is not triggered.

## 7.11 Simulation

### 7.11.1 Set simulation value pressure

<ul style="list-style-type: none"> <li>▶ Select [S.PRS].</li> <li>▶ Set the process value to be simulated</li> </ul> <p>[Numerical value] = Pressure (depending on basic setting)  [OL] = Detection range exceeded  [UL] = Below the detection range (depending on measuring range)  [Err] = Electronic error detected</p>	[S.PRS]
--	---------

### 7.11.2 Set simulation value temperature

<ul style="list-style-type: none"> <li>▶ Select [S.TMP]</li> <li>▶ Set the process value to be simulated</li> </ul> <p>[Numerical value] = Temperature (depending on basic setting)  [OL] = Detection range exceeded  [UL] = Below detection range  [Err] = Electronic error detected  [cr.OL] = Temperature range critically exceeded  [cr.UL] = Critically below temperature range</p>	[S.TMP]
--	---------

### 7.11.3 Set simulation duration

<ul style="list-style-type: none"> <li>▶ Select [S.Tim]</li> <li>▶ Set time span for simulation</li> </ul> <p>Setting range: 1, 2, 3, 4, 5, 10, 15, 20, 30, 45, 60 min.</p>	[S.Tim]
---	---------

### 7.11.4 Switch simulation on / off

<ul style="list-style-type: none"> <li>▶ Select [S.On] and set:</li> </ul> <p>[SIMU_START] = Simulation on  [SIMU_STOP] = Simulation off</p>	[S.On]
--	--------



Simulation active until system command [SIMU\_STOP] is sent or the time set via [STim] elapses. After the simulation, the unit switches back to operating mode.

## 7.12 List of the parameters

Parameter	Function
ASP2	Analogue start point: 4 mA.

Parameter	Function
AEP2	Analogue end point: 20 mA.
uni.P	Unit of measurement for system pressure.
uni.T	Unit of measurement for medium temperature.
FOU2	Status of output 2 in case of an error.
coF	Zero-point calibration.
dAA	Damping for the analogue output.
dAP.P	Damping of the process value pressure.
Lo.P	Minimum value memory for the system pressure.
Hi.P	Maximum value memory for the system pressure.
Lo.T	Minimum value memory for the medium temperature.
Hi.T	Maximum value memory for the medium temperature.
ou2	Output function for OUT2.
S.PRS	Simulation of a pressure / event.
S.TMP	Simulation of a temperature / event.
S.TIM	Simulation time
S.On	Simulation start / stop.
HIPS	Setting of the pressure limit for the counter [HIPC].
HIPC	Number of times the pressure limit is exceeded [HIPS].
HITS	Setting of the temperature limit for the counter [HITC].
HITC	Number of times the temperature limit is exceeded [HITS].
Internal_Temperature	Reading of the internal device temperature.
Operating_Hours	Operating hours counter
Event_History	List of the last 20 events that occurred.
Event_Counter	Event counter

## 7.13 List of system commands

Command	Function
Teach_COF	Teaching the zero point.
RESET_COF	Reset of the zero-point calibration.
TEACH_ASP2	Teaching the analogue start point for system pressure.
TEACH_AEP2	Teaching the analogue end point for system pressure.
FLASH_ON	Start of the visual localisation of the sensor.
FLASH_OFF	Stop of the visual localisation of the sensor.
SIMU_START	Start of the simulation.
SIMU_STOPP	Stop of the simulation.
BackToBox	Performing the Reset Back to Box.
ApplicationReset	Perform the application reset.
RESET_HI_PRES	Reset the maximum value memory for system pressure [Hi.P].
RESET_LO_PRES	Reset the minimum value memory for system pressure [Lo.P].
RESET_HI_LO_PRESS	Reset the max. and min. value memory for system pressure [Hi.P] and [Lo.P].
RESET_HI_TEMP	Reset the maximum value memory for media temperature [Hi.T].
RESET_LO_TEMP	Reset the minimum value memory for media temperature [Lo.T].
RESET_HI_LO_TEMP	Reset the max. and min. value memory for media temperature [Hi.T] and [Lo.T].

Command	Function
RESET_HITC	Reset the temperature threshold counter [HITC].
RESET_HIPC	Reset the pressure threshold counter [HIPC].
RESET_EVENT_HISTORY	Reset the recorded events.
RESET_EVENT_COUNTER	Reset the event counter.
Test Event 1	Test Event
Test Event 2	Test Event

## 8 Operation

After switching on the supply voltage and expiry of the power-on delay time (2-wire: approx. 1 s / 3-wire: approx. 0.5 s), the device is in the RUN mode (= normal operating mode). It carries out its measurement and evaluation functions and generates output signals according to the set parameters.

## 9 Troubleshooting

The unit has many self-diagnostic options.

It monitors itself automatically during operation. Warnings and faults are signalled via IO-Link. If a process value fails, the other process values are still available.



Additional diagnostic functions are available via IO-Link.

IODD interface description at: [www.ifm.com](http://www.ifm.com).



The IO-Link error codes are contained in the IODD.

Event	Type	Description	**Output status	IO-Link process value	Device status	Troubleshooting
Hardware failure (HWF)	Error	Unit faulty / malfunction	FOU	not valid	4	Replace device
Parameter setting fault	Error	Parameter setting outside the valid range	FOU	not valid	3	Repeat parameter setting
Component error	Error	Error in pressure measurement.	FOU	valid	3	Check pressure measurement. Replace device.
	Error	Error in temperature measurement	FOU	valid	3	Check temperature measurement. Replace device.
Process variable range over-run	Warning	Pressure range exceeded ( $\geq 105\%$ VMR*) or temperature range exceeded ( $\geq 115^{\circ}\text{C}$ / $239^{\circ}\text{F}$ )	OU	valid	2	Check the pressure range / temperature range.
Process variable range under-run	Warning	Below pressure range ( $\geq -5\%$ VMR*) or below temperature range ( $\geq -30^{\circ}\text{C}$ / $-22^{\circ}\text{F}$ )	OU	valid	2	Check the pressure range / temperature range.
Below measuring range	Error	Critically below temperature range ( $\leq -35^{\circ}\text{C}$ / $-31^{\circ}\text{F}$ )	FOU	valid	3	Check the temperature range.
Measuring range exceeded	Error	Temperature range critically exceeded ( $\geq 125^{\circ}\text{C}$ / $257^{\circ}\text{F}$ )	FOU	valid	3	Check the temperature range.
Device temperature exceeded	Warning	Device temperature exceeded ( $> 125^{\circ}\text{C}$ / $257^{\circ}\text{F}$ )	OU	valid	2	Check device temperature.
Below device temperature	Warning	Below device temperature ( $< -25^{\circ}\text{C}$ / $-13^{\circ}\text{F}$ )	OU	valid	2	Check device temperature.
Faulty voltage supply	Error	Supply voltage too low	Off	Off	Off	Check the supply voltage

\*VMR = final value of the measuring range

\*\*Output status: in case of a fault the analogue output behaves according to the setting at [FOU2]. In case of a warning the analogue signal is as defined in the parameters [OU].

## 10 Disposal, repair and return

- ▶ After use dispose of the unit in an environmentally friendly way in accordance with the applicable national regulations.
- ▶ In case of return shipment, ensure that the unit is free from soiling, especially from dangerous and toxic substances.
- ▶ It is not possible to repair the unit.



## 11 Factory setting

	Factory setting	User settings
ASP2/TEACH_ASP2	0% VMR *	
AEP2/TEACH_AEP2	VMR	
uni.t	°C	
uni.P	mbar / bar	
dAP.P	0.06	
dAA	0.1	
ou2	l	
FOU2	OFF	
cof / TEACH_COF	0	
S.PRS	50% VMR *	
S.TMP	50% VMR *	
S.TIM	3	
S.On	OFF	
HIPS	VMR	
HIPC	0	
HITS	VMR	
HITC	0	

VMR = final value of the measuring range

\*= the indicated percentage of the final value of the measuring range (VMR) of the corresponding sensor is set.