



CE

Operating instructions
Electronic pressure sensor

PI22xx

PI23xx

UK

12 / 2020

80009157 / 01

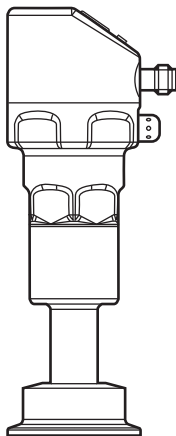

Contents

1	Preliminary note	4
1.1	Symbols used	4
2	Safety instructions	4
3	Functions and features	5
3.1	Applications	5
4	Function	5
4.1	Operating modes	6
4.1.1	2-wire operation	6
4.1.2	3-wire operation	6
4.2	Switching function (only for 3-wire operation)	6
4.3	Analogue function	7
4.4	Customer-specific calibration	8
4.5	IO-Link	10
4.5.1	General information	10
4.5.2	Device-specific information	10
4.5.3	Parameter setting tools	10
5	Installation	10
5.1	Connection versions clamp seals	10
5.2	Use in hygienic areas to EHEDG	12
5.3	Ventilation diaphragm	12
5.3.1	Function ventilation diaphragm	12
5.3.2	Orientation	13
5.4	Filter cover	14
6	Electrical connection	15
6.1	Connection for 2-wire operation	15
6.2	Connection for IO-Link parameter setting	15
6.3	Connection for 3-wire operation	16
7	Operating and display elements	17
8	Menu	18
8.1	Menu structure: main menu	18
8.2	Explanation of the main menu	19
8.3	Menu structure: level 2 (extended functions)	20
8.4	Explanation of menu level 2	21

8.5	Menu structure: level 3 (simulation)	22
8.6	Explanation of menu level 3	23
9	Parameter setting	24
9.1	Parameter setting in general	24
9.2	Configure display (optional)	26
9.3	Set output signals	27
9.3.1	Set output functions	27
9.3.2	Set switching limits	27
9.3.3	Scale analogue value for OUT2	28
9.4	User settings (optional)	29
9.4.1	Carry out zero point calibration	29
9.4.2	Set output status in fault condition	29
9.4.3	Set delay time for the switching outputs	29
9.4.4	Set output logic for the switching outputs	29
9.4.5	Set damping for the switching signal	30
9.4.6	Set damping for the analogue signal	30
9.4.7	Calibrate curve of measured values	30
9.5	Service functions	31
9.5.1	Read min/max values for the system pressure	31
9.5.2	Reset all parameters to factory setting	31
9.6	Simulation function	31
9.6.1	Open menu level 3 (simulation)	31
9.6.2	Set simulation value	32
9.6.3	Set time for simulation	32
9.6.4	Start simulation	32
10	Operation	33
10.1	Read the set parameters	33
10.2	Change the display in the Run mode	33
10.3	Self-diagnostics / fault indications	33
11	Technical data	36
11.1	Setting ranges	36
11.2	Technical data	36
12	Factory setting	37

1 Preliminary note

1.1 Symbols used

- ▶ Instructions
- > Reaction, result
- [...] Designation of keys, buttons or indications
- Cross-reference



Important note

Non-compliance may result in malfunction or interference.



Information

Supplementary note.

2 Safety instructions

- The device described is a subcomponent for integration into a system.
 - The manufacturer of the system is responsible for the safety of the system.
 - The system manufacturer undertakes to perform a risk assessment and to create a documentation in accordance with legal and normative requirements to be provided to the operator and user of the system. This documentation must contain all necessary information and safety instructions for the operator, the user and, if applicable, for any service personnel authorised by the manufacturer of the system.
- Read this document before setting up the product and keep it during the entire service life.
- The product must be suitable for the corresponding applications and environmental conditions without any restrictions.
- Only use the product for its intended purpose (→ Intended use).
- Only use the product for permissible media (→ Technical data).
- If the operating instructions or the technical data are not adhered to, personal injury and/or damage to property may occur.
- The manufacturer assumes no liability or warranty for any consequences caused by tampering with the product or incorrect use by the operator.
- Installation, electrical connection, set-up, operation and maintenance of the unit must be carried out by qualified personnel authorised by the machine operator.
- Protect units and cables against damage.

3 Functions and features

The unit measures and monitors the system pressure in a plant.

3.1 Applications

Type of pressure: relative pressure



Information on pressure rating and bursting pressure → data sheet.



Avoid static and dynamic overpressure exceeding the specified overload pressure by taking appropriate measures.

The indicated bursting pressure must not be exceeded.

Even if the bursting pressure is exceeded only for a short time, the unit may be destroyed. ATTENTION: risk of injury!

Not suitable for use where the criteria for paragraph D10.2/63-03 of the 3-A standard 63-03 have to be met.



The units are vacuum resistant.

4 Function

- The unit displays the current system pressure.
- It generates output signals according to the operating mode and the parameter setting.
- Moreover, it provides the process data via IO-Link.
- The unit is designed for fully bidirectional communication.

So the following options are possible:

- Remote display: reading and display of the current system pressure.
- Remote parameter setting: reading and changing the current parameter setting.
- IO-Link parameter setting (→ 4.5)

4.1 Operating modes

The operating mode is defined by the wiring (→ 6 Electrical connection) and automatically recognised by the unit.

4.1.1 2-wire operation

OUT2 (pin 2)	Analogue signal proportional to pressure 4...20 mA or 20...4 mA
--------------	---

4.1.2 3-wire operation

OUT1 (pin 4)	<ul style="list-style-type: none">• Switching signal for system pressure limit• Communication via IO-Link
OUT2 (pin 2)	3 options: <ul style="list-style-type: none">• Switching signal for system pressure limit• Analogue signal proportional to pressure 4...20 mA• Analogue signal proportional to pressure 20...4 mA

4.2 Switching function (only for 3-wire operation)

OUTx changes its switching status if it is above or below the set switching limits (SPx, rPx). The following switching functions can be selected:

- Hysteresis function / normally open: [OUx] = [Hno] (→ fig. 1).
- Hysteresis function / normally closed: [OUx] = [Hnc] (→ fig. 1).

First the set point (SPx) is set, then the reset point (rPx) with the requested difference.

- Window function / normally open: [OUx] = [Fno] (→ fig. 2).
- Window function / normally closed: [OUx] = [Fnc] (→ fig. 2).

The width of the window can be set by means of the difference between SPx and rPx. SPx = upper value, rPx = lower value.

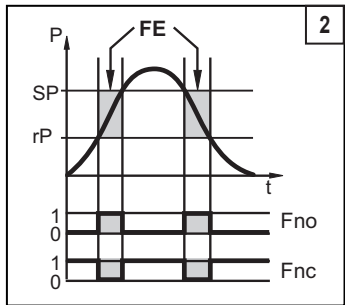
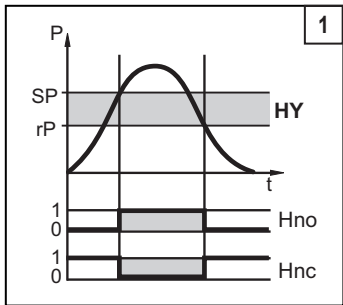

P = system pressure; HY = hysteresis; FE = window

4.3 Analogue function

The analogue output can be configured.

- [OU2] defines whether the set measuring range is provided as 4...20 mA ([OU2] = [I]) or as 20...4 mA ([OU2] = [InEG]).

Scaling can be set by means of the teach process or by entering a value for the parameters ASP and AEP.

- Teaching the analogue start point [tASP] or setting the parameter [ASP] defines at which measured value the output signal is 4 mA (20 mA with [InEG]).
- Teaching the analogue end point [tAEP] or setting the parameter [AEP] defines at which measured value the output signal is 20 mA (4 mA with [InEG]).

Minimum distance between [ASP] and [AEP] = 25 % of the final value of the measuring range (turn-down 1:4); for PI2x09: 25 % of the measuring span.

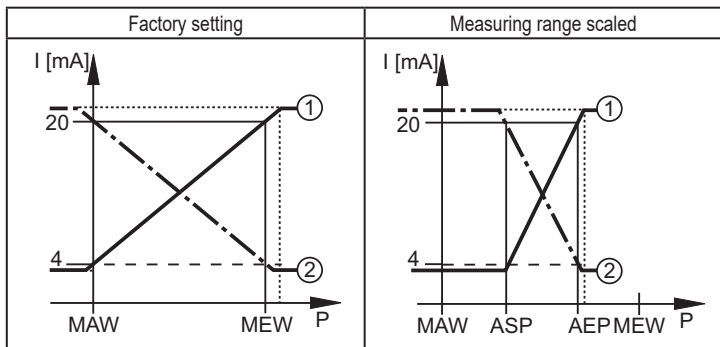

P = system pressure , MAW = initial value of the measuring range, MEW = final value of the measuring range

①: [OU2] = [I] ②: [OU2] = [InEG]

In the set measuring range the output signal is between 4 and 20 mA ([OU2] = [I]) or between 20 and 4 mA ([OU2] = [InEG]).

It is also indicated:

- System pressure above the measuring range:
 - Output signal > 20 mA if [OU2] = [I].
 - Output signal 4 to 3.8 mA if [OU2] = [InEG].
- System pressure below the measuring range:
 - Output signal 4 to 3.8 mA if [OU2] = [I].
 - Output signal > 20 mA if [OU2] = [InEG].

4.4 Customer-specific calibration

The customer-specific calibration changes the curve of measured values compared to the real measured values (shifting / change of the gradient → 9.4.6 [CAL]).

- Two calibration points can be defined (CP1, CP2). The two points are independent of each other.
- The two calibration points must be within the scaled measuring range (→ 4.3 Pressure monitoring / analogue function).

- The zero point calibration [COF] influences the calibration of the curve of measured values. Recommendation: set [COF] to 0 (\rightarrow 9.4.1 [COF]), then calibrate the curve of measured values.

After a change the calibration can be reset to factory setting (\rightarrow 9.5.2 [rES]).

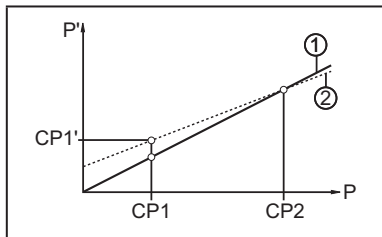

- P = measured pressure
- P' = modified measured value
- CP1 = calibration point 1
- CP1' = modified measured value for CP1
- CP2 = calibration point 2
- 1 = curve of measured values with factory setting
- 2 = curve of measured values after calibration

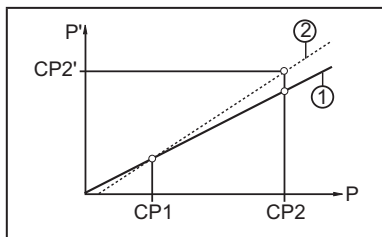

- P = measured pressure
- P' = modified measured value
- CP1 = calibration point 1
- CP2 = calibration point 2
- CP2' = modified measured value for CP2
- 1 = curve of measured values with factory setting
- 2 = curve of measured values after calibration

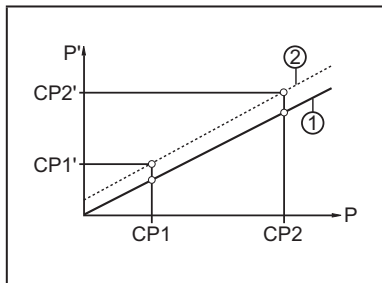

- P = measured pressure
- P' = modified measured value
- CP1 = calibration point 1
- CP1' = modified measured value for CP1
- CP2 = calibration point 2
- CP2' = modified measured value for CP2
- 1 = curve of measured values with factory setting
- 2 = curve of measured values after calibration

4.5 IO-Link

4.5.1 General information

This unit has an IO-Link communication interface which requires an IO-Link-capable module (IO-Link master) for operation.

The IO-Link interface enables direct access to the process and diagnostic data and provides the possibility to set the parameters of the unit during operation. In addition, communication is possible via a point-to-point connection with a USB adapter cable.

More information about IO-Link → www.ifm.com.

4.5.2 Device-specific information



IODDs necessary for the configuration of the IO-Link unit and detailed information about process data structure, diagnostic information and parameter addresses → www.ifm.com.

4.5.3 Parameter setting tools

All necessary information about the required IO-Link hardware and software → www.ifm.com.

5 Installation

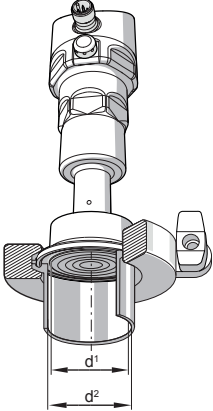
5.1 Connection versions clamp seals

Clamp connection to pipe to DIN 11866	Effective diameter PI22xx: Deff = 34 mm	Effective diameter PI23xx: Deff = 47.5 mm	
Series A - metric	nominal width DN 40 Di = 38 mm	nominal width DN 50 Di = 50 mm	
Series B - ISO	nominal width DN / OD 42.4 Di = 38.4 mm	-----	
Series C - ASME	nominal width DN / OD 1 1/2" Di = 34.8 mm	nominal width DN / OD 2" Di = 47.5 mm	
 Internal pipe diameter D_i (d_2) > diameter of the effective area of the diaphragm D_{eff} (d_1).			



- ▶ Before installing and removing the unit: Make sure that no pressure is applied to the system. Please note when the system pressure is displayed in % of the span: "0" does not mean that no pressure is applied to the system!
- ▶ The diaphragm must not be dented or cleaned with pointed or hard objects!
- ▶ The system seal must not be in contact with the diaphragm.



The installation position of the sensor influences the hydrostatic pressure of the fill fluid in the capillary tube of the diaphragm seal unit. A zero shift (i.e. when no pressure is applied to the system, "zero" is not displayed as a measured value) as a consequence of the installation position of the sensor can be corrected via the menu (→ 9.4.1).

UK

Use in hygienic areas to 3-A: orientation of the unit in pipes and tanks

Please note for optimised cleaning of the measuring element according to the 3-A criteria for hygienic areas:

To ensure that the medium can completely flow off the area of the diaphragm seal when the pipes or tanks are empty, choose positions 1 - 3 of the generally possible installation positions 1 - 5 (see figure on the right).

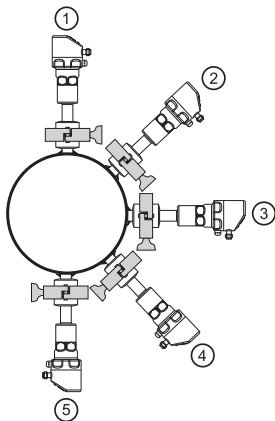

5.2 Use in hygienic areas to EHEDG



The sensor is suited for CIP (clean in place) when installed correctly.

- ▶ Observe the application limits (temperature and material resistance) according to the data sheet.
 - ▶ Make sure that the sensor is integrated into the system according to EHEDG:
 - ▶ Use self-draining installation.
 - ▶ Only use process adapters permitted according to EHEDG with special seals required by the EHEDG position paper.
-  The gasket of the system interface must not be in contact with the effective area of the diaphragm (→ 5.1).
- ▶ For any structures in a tank, direct water jet cleaning and cleaning of any dead spaces must be possible.

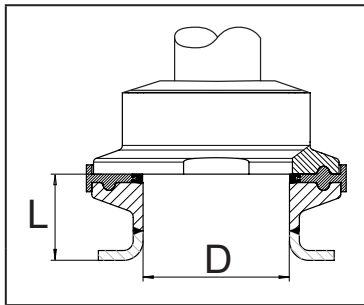

- ▶ To avoid dead space adhere to the dimensions:
 $L < (D)$.

5.3 Ventilation diaphragm

5.3.1 Function ventilation diaphragm

The ventilation diaphragm enables the relative pressure measurement since barometric and temperature-dependent pressure fluctuations between the measuring cell and the environment are compensated for.

The ventilation diaphragm is protected against damage by a screwed filter cover with circumferential ports.



For a correct functioning of the diaphragm please take the following into account:

- ▶ Remove soiling and cleaning agents immediately using plenty of lime-deficient splash water.



If the sensor is in a cooling stage:

- ▶ Avoid contact of the diaphragm with liquids:
 - > Avoids negative pressure in the measuring system resulting in a slightly falsified measured value and additional strain on the diaphragm.

UK

5.3.2 Orientation

When the sensor is mounted in a vertical position, the condensate escapes through the ports in the filter cover due to gravity.



When the sensor is mounted in a horizontal position and the display is facing upwards or downwards, the escape of the condensate through the filter cover is reduced since it is at the highest or lowest position (→ Fig. Orientation of the filter cover).

- ▶ Recommendation:

Use accessories (→ 9.4.1, 4) to bring the ventilation diaphragm into a vertical position = ideal orientation (1).

- > The condensate can escape faster due to gravity.

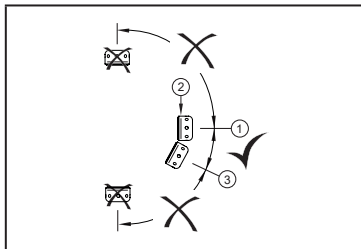

- ▶ Ideal orientation (1):
Filter cover in horizontal position.
The ventilation diaphragm (2)
in the filter cover is in a vertical
position.
- ▶ Maximum inclination: 30° (3)

Fig.: Orientation filter cover

5.4 Filter cover

Replace filter cover:

1	Exchange the filter cover incl. GORE diaphragm (E30142).
2	Replace the filter cover with a closed version (E30148) (*)

Improve the protection of the filter cover:

3	Replace the filter cover with a version with a tube fitting and a vent tube that ends in a protected and dry area (E30139).
4	Set of accessories (E30467) with integrated replacement diaphragm (GORE), for high degree of soiling and / or high climate pollution. Function: (→ Installation instructions E30467)



- ▶ Avoid soiling and moisture during the replacement
- ▶ Clean the thread carefully and without residues
- ▶ Do not damage the adhesive area of the sensor
- ▶ Observe the orientation of the filter cover
(→ Installation instructions E30139 / 30467)

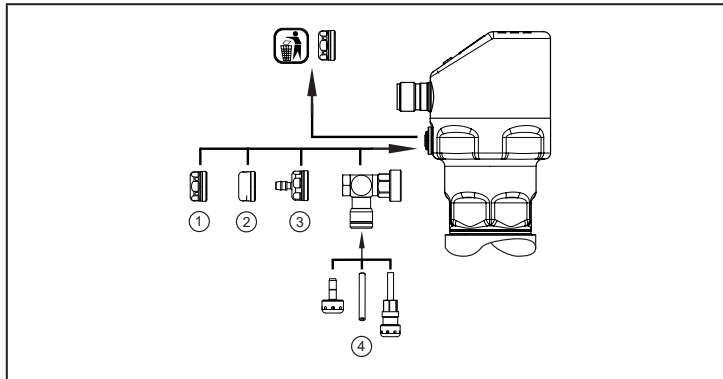



(*) When using the closed filter cover, there is no pressure compensation of the measuring cell any more. This results in measurement deviations caused by:

- fluctuations of the atmospheric pressure
- pressure fluctuations inside the unit in case of temperature changes ($\Delta 10\text{ K} \leq 30\text{ mbar}$).

6 Electrical connection



The unit must be connected by a qualified electrician.

The national and international regulations for the installation of electrical equipment must be adhered to.

Voltage supply according to EN 50178, SELV, PELV.

- ▶ Disconnect power.
- ▶ Connect the unit as follows:

6.1 Connection for 2-wire operation

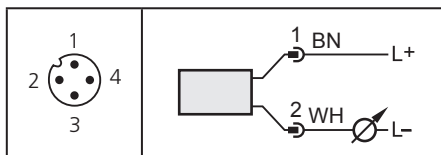

Colours to DIN EN 60947-5-2

6.2 Connection for IO-Link parameter setting

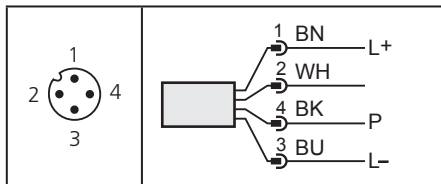

Colours to DIN EN 60947-5-2

Pin 1	L+
Pin 2	Output function according to the OU2 setting
Pin 3	L- for programming mode
Pin 4 (P)	Communication via IO-Link

6.3 Connection for 3-wire operation

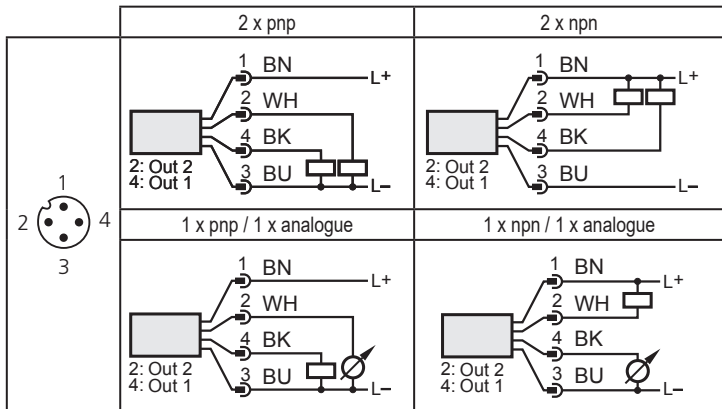

Colours to DIN EN 60947-5-2

Pin 1	L+
Pin 3	L-
Pin 4 (OUT1)	<ul style="list-style-type: none"> • Binary switching output pressure monitoring • Communication via IO-Link
Pin 2 (OUT2)	Binary switching output pressure monitoring or analogue output for system pressure

7 Operating and display elements

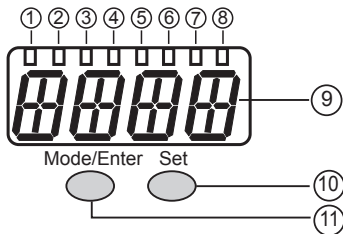

1 to 8: Indicator LEDs

- LED 1 to LED 5 = system pressure in the specified unit of measurement.
- LED 6 = system pressure in % of the set scaling of the analogue output (range ASP to AEP) if [OU2] is configured as analogue output.
System pressure in % of the final value of the measuring range if [OU2] is configured as switching output.
- LED 7 = switching status OUT2 (on if output 2 is switched).
- LED 8 = switching status OUT1 (on if output 1 is switched).

9: Alphanumeric display, 4 digits

- Display of the current system pressure.
- Display of the parameters and parameter values.

10: Set button

- Setting of the parameter values (scrolling by holding pressed, incrementally by pressing once).

11: Mode/Enter button

- Selection of the parameters and acknowledgement of the parameter values.

8 Menu

8.1 Menu structure: main menu

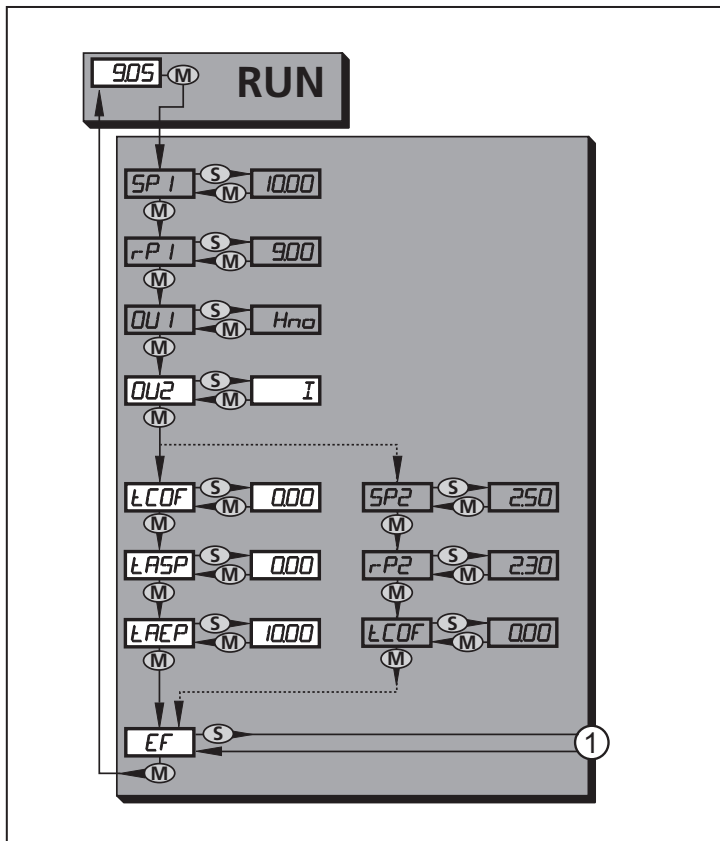

1: Change to menu level 2 (extended functions)

Menu items highlighted in grey (**SP1**) are not active in 2-wire operation.

8.2 Explanation of the main menu

SP1/rP1*	Upper / lower limit for system pressure at which OUT1 switches.
OU1*	Output function for OUT1: <ul style="list-style-type: none">• Switching signal for the pressure limits: hysteresis function [H ..] or window function [F ..], either normally open [. no] or normally closed [. nc].
OU2	Output function for OUT2: <ul style="list-style-type: none">• Switching signal for the pressure limits: hysteresis function [H ..] or window function [F ..], either normally open [. no] or normally closed [. nc] (only available for 3-wire operation).• Analogue signal for the current system pressure: 4...20 mA [I], 20...4 mA [InEG].
tCOF	Teach zero-point calibration.
tASP	Teach analogue start point for system pressure: set measured value at which 4 mA is provided (20 mA if [OU2] = [InEG]).
tAEP	Teach analogue end point for system pressure: set measured value at which 20 mA is provided (4 mA if [OU2] = [InEG]).
SP2/rP2*	Upper / lower limit for system pressure at which OUT2 switches.
EF	Extended functions / opening of menu level 2.

* menu items not active in 2-wire operation

UK

8.3 Menu structure: level 2 (extended functions)

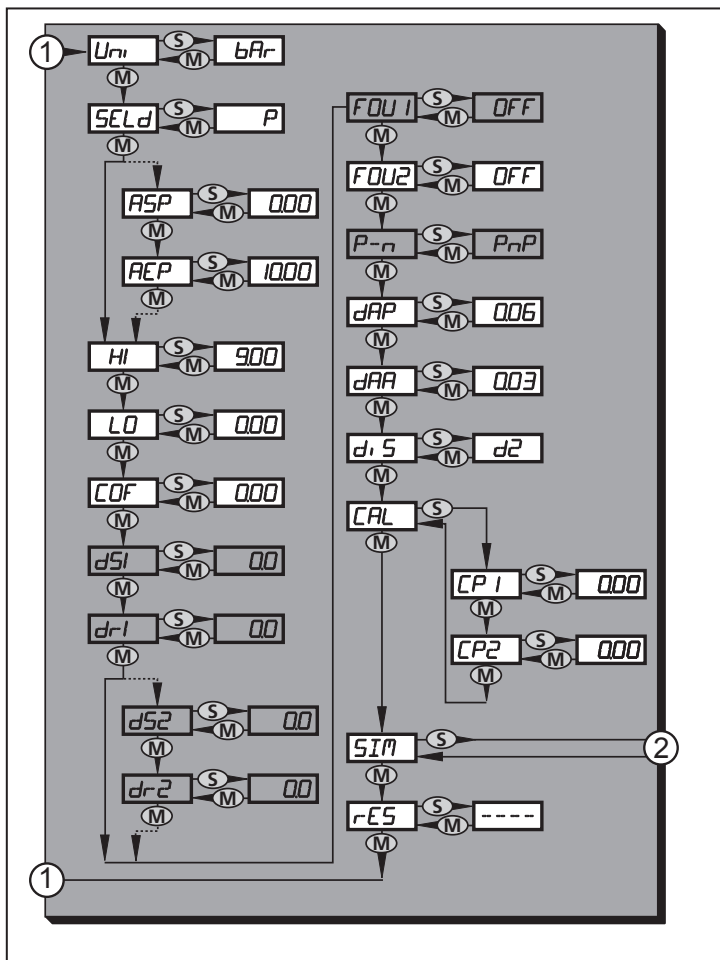

1: Change to the main menu, 2: Change to menu level 3 (simulation).

Menu items highlighted in grey (**ASP**) are not active in 2-wire operation.

8.4 Explanation of menu level 2

Uni	Standard unit of measurement for system pressure.
SELd	Display mode: <ul style="list-style-type: none"> • Pressure in the unit set in [Uni]. • Pressure in % of the set scaling of the analogue output.
ASP	Analogue start point for system pressure: measured value at which 4 mA is provided (20 mA if [OU2] = [InEG]).
AEP	Analogue end point for system pressure: measured value at which 20 mA is provided (4 mA if [OU2] = [InEG]).
HI	Maximum value memory for system pressure.
LO	Minimum value memory for system pressure.
COF	Zero-point calibration.
dS1*	Switch-on delay for OUT1.
dr1*	Switch-off delay for OUT1.
dS2*	Switch-on delay for OUT2, only active if [OU2] = [Hnc], [Hno], [Fnc] or [Fno].
dr2*	Switch-off delay for OUT2, only active if [OU2] = [Hnc], [Hno], [Fnc] or [Fno].
FOU1*	Status of output 1 in case of an internal fault.
FOU2	Status of output 2 in case of an internal fault.
P-n*	Switching logic for the outputs: pnp or npn.
dAP	Damping for switching outputs and display.
dAA	Damping for analogue output (OUT2), also has an effect on the IO-Link process value.
diS	Update rate and orientation of the display.
CAL	Calibration function (setting the curve of measured values).
CP1	Calibration point 1.
CP2	Calibration point 2.
SIM	Change to menu level 3 (simulation).
rES	Restore factory setting.

UK

* menu items not active in 2-wire operation

8.5 Menu structure: level 3 (simulation)

With setting SEL = OU

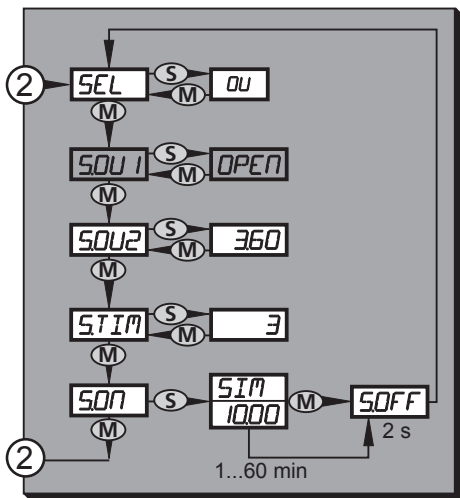

With setting SEL = Proc

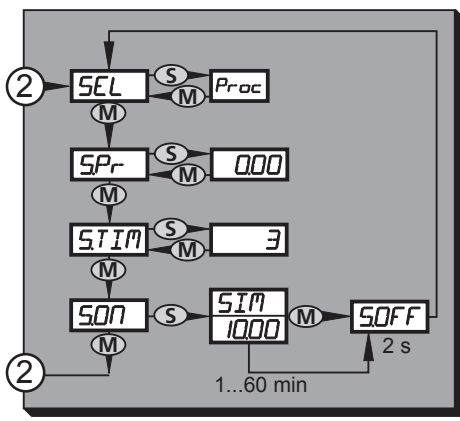

2: Change to menu level 2 (extended functions)

Menu items highlighted in grey (S.OU1) are not active in 2-wire operation.

8.6 Explanation of menu level 3

With setting SEL = OU	
SEL	Status to be simulated: • Output functions [OU].
S.OU1*	Simulation values for OUT1, only active for 3-wire operation and if [SEL] = [OU]. • Output inactive [OPEN] or output active [CLOS].
S.OU2	Simulation values for OUT2, only active if [SEL] = [OU]. • For 3-wire operation and if OUT2 has been configured as switching output: output inactive [OPEN] or active [CLOS]. • If OUT2 is set as analogue output: analogue signal between 3.6 and 21.1 mA (depending on the set value → 9.6.2).
S.TIM	Time for the simulation process in minutes.
S.ON	Start of the simulation process. During the simulation process the display alternately shows [SIM] and the current operation indication (→ 9.6.4). If the simulation process is aborted (briefly press [Mode/Enter] or [Set]) [S.OFF] is indicated for 2 s, then [SEL] is active again.

* menu item not active in 2-wire operation

With setting SEL = Proc	
SEL	Status to be simulated: • Process value [Proc].
S.Pr	Simulation of a process value, only active if [SEL] = [Proc]. • Any value between initial value of the measuring range and final value of the measuring range.
S.TIM	Time for the simulation process in minutes.
S.ON	Start of the simulation process. During the simulation process the display alternately shows [SIM] and the current operation indication (→ 9.6.4). If the simulation process is aborted (briefly press [Mode/Enter] or [Set]) [S.OFF] is indicated for 2 s, then [SEL] is active again.

UK



9 Parameter setting

During parameter setting the unit remains in the operating mode. It continues to monitor with the existing parameters until the parameter setting has been completed.

Exceptions: Changes to the parameters COF (→ 9.4.1), CP1 and CP2 (→ 9.4.7) take effect immediately.

9.1 Parameter setting in general

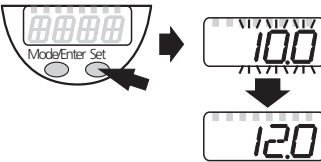

3 steps must be taken for each parameter setting:

<p>1 Select parameter</p> <ul style="list-style-type: none">▶ Press [Mode/Enter] until the requested parameter is displayed. <p>If the main menu is protected by an access code, [Cod0] flashes in the display.</p> <ul style="list-style-type: none">▶ Press and hold down [Set] until the valid code no. is displayed.▶ Briefly press [Mode/Enter]. <p>When delivered by ifm electronic: no access restriction.</p>	 <p>The diagram shows a control panel with a display showing 'Cod0'. An arrow points to the 'Mode/Enter' button. A second arrow points to the 'Set' button. The final display shows 'SP 1'.</p>
<p>2 Set parameter value</p> <ul style="list-style-type: none">▶ Press and hold down [Set].> Current setting value of the parameter flashes for 5 s.> After 5 s: setting value is changed: incrementally by pressing the button once or scrolling by holding pressed.	 <p>The diagram shows the control panel with the display flashing '100'. An arrow points to the 'Set' button. A second arrow points to the 'Set' button. The final display shows '120'.</p>
<p>Numerical values are incremented continuously. For reducing the value: let the display move to the maximum setting value. Then the cycle starts again at the minimum setting value.</p>	
<p>3 Acknowledge parameter value</p> <ul style="list-style-type: none">▶ Briefly press [Mode/Enter].> The parameter is displayed again. The new setting value is saved.	 <p>The diagram shows the control panel with the display showing 'SP 1'. An arrow points to the 'Mode/Enter' button.</p>
<p>Set other parameters</p> <ul style="list-style-type: none">▶ Start again with step 1.	
<p>Finish parameter setting</p> <ul style="list-style-type: none">▶ Press [Mode/Enter] several times until the current measured value is displayed or wait for 15 s.> The unit returns to the operating mode.	



For 2-wire operation the menu items that refer to switching functions are not active (→ 8 Menu structure); in addition, for some menu items the parameter values that refer to switching functions cannot be selected.

- If [SLoc] is displayed when attempting to change a parameter value, the sensor is locked by the software. This locking can only be removed with a parameter setting software.
- For IO-Link parameter setting → device-specific parameter lists at: www.ifm.com
- Change from menu level 1 to menu level 2:

<p>▶ Press [Mode/Enter] until [EF] is displayed.</p>	
<p>▶ Briefly press [Set]. > The first parameter of the submenu is displayed (here: [Uni]).</p> <p>If menu level 2 is protected by an access code, "Cod1" flashes in the display.</p> <p>▶ Press and hold down [Set] until the valid code no. is displayed.</p> <p>▶ Briefly press [Mode/Enter].</p> <p>When delivered by ifm electronic: no access restriction.</p>	

UK

- Lock / unlock

The unit can be locked electronically to prevent unintentional settings.

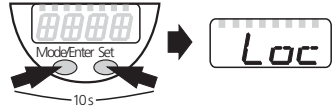
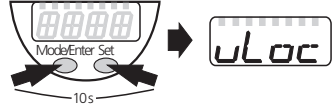
<ul style="list-style-type: none"> ▶ Make sure that the unit is in the normal operating mode. ▶ Press [Mode/Enter] + [Set] for 10 s. > [Loc] is displayed. 	
<p>During operation: [Loc] is briefly displayed if you try to change parameter values.</p>	
<p>For unlocking:</p> <ul style="list-style-type: none"> ▶ Press [Mode/Enter] + [Set] for 10 s. > [uLoc] is displayed. 	

On delivery: not locked.

- Timeout:

If no button is pressed for 15 s during parameter setting, the unit returns to the operating mode with unchanged values.

9.2 Configure display (optional)

<ul style="list-style-type: none"> ▶ Select [Uni] and set the unit of measurement: <ul style="list-style-type: none"> - [bAr], [mbAr] - [MPa], [kPa] - [PSI] - [InHO] (only PI2xx6, PI2xx7, PI2xx9) - [mWS] (only PI2xx6, PI2xx7, PI2xx9) 	<p><i>Uni</i></p>
<ul style="list-style-type: none"> ▶ Select [SELD] and set type of display: <ul style="list-style-type: none"> - [P]: system pressure in the unit set in Uni. - [P%]: system pressure in % of the set scaling of the analogue output; the following applies: 0 % = ASP value / 100 % = AEP value. <p>If OU2 is configured as switching output, [ASP] and [AEP] are not active. In this case the following applies: 0 % = initial value of the measuring range / 100 % = final value of the measuring range.</p> <p>If [SELD] = [P%] please note the following: "0" does not mean that no pressure is applied to the system!</p> 	<p><i>SELD</i></p>

<p>▶ Select [dIS] and set the update rate and orientation of the display:</p> <ul style="list-style-type: none"> - [d1]: update of the measured values every 50 ms. - [d2]: update of the measured values every 200 ms. - [d3]: update of the measured values every 600 ms. - [rd1], [rd2], [rd3]: display as with d1, d2, d3; rotated by 180°. - [OFF] = The measured value display is deactivated in the Run mode. When one of the buttons is pressed the current measured value is displayed for 15 s. Pressing the [Mode/Enter] button again activates the display mode. The LEDs remain active even if the display is deactivated. <p>Error messages are displayed even if the display is deactivated.</p>	
--	--

UK

9.3 Set output signals

9.3.1 Set output functions

<p>▶ Select [OU1] and set the switching function:</p> <ul style="list-style-type: none"> - [Hno] = hysteresis function/normally open - [Hnc] = hysteresis function/normally closed - [Fno] = window function/normally open - [Fnc] = window function/normally closed 	
<p>▶ Select [OU2] and set the function:</p> <ul style="list-style-type: none"> - [Hno] = hysteresis function/normally open - [Hnc] = hysteresis function/normally closed - [Fno] = window function/normally open - [Fnc] = window function/normally closed - [I] = current signal proportional to pressure 4...20 mA - [InEG] = current signal proportional to pressure 20...4 mA 	

9.3.2 Set switching limits

<p>▶ Select [SP1] / [SP2] and set the value at which the output is set.</p>	
<p>▶ Select [rP1] / [rP2] and set the value at which the output is reset. rPx is always lower than SPx. The unit only accepts values which are lower than the value for SPx.</p>	

9.3.3 Scale analogue value for OUT2

<ul style="list-style-type: none">▶ Set the minimum pressure requested in the system.▶ Press [Mode/Enter] until [tASP] appears.▶ Press and hold down [Set].<ul style="list-style-type: none">> Current setting value flashes.▶ Release [Set] when the display stops flashing.<ul style="list-style-type: none">> New setting value is displayed.▶ Briefly press [Mode/Enter].<ul style="list-style-type: none">> The current system pressure is defined as start value for the analogue signal.	tASP
<ul style="list-style-type: none">▶ Set the maximum pressure requested in the system.▶ Press [Mode/Enter] until [tAEP] appears.▶ Press and hold down [Set].<ul style="list-style-type: none">> Current setting value flashes.▶ Release [Set] when the display stops flashing.<ul style="list-style-type: none">> New setting value is displayed.▶ Briefly press [Mode/Enter].<ul style="list-style-type: none">> The current system pressure is defined as end value for the analogue signal.	tAEP
<p>ASP / AEP can only be set within defined limits (→ 12.1 Setting ranges). If setting is carried out with an invalid pressure value, [UL] or [OL] is displayed. After acknowledgement by [Mode/Enter] [Err] flashes, the ASP value / AEP value is not changed.</p>	
<p>Alternatively:</p> <ul style="list-style-type: none">▶ Select [ASP] and set the measured value at which 4 mA is provided (20 mA if [OU2] = [InEG]).▶ Select [AEP] and set the measured value at which 20 mA is provided (4 mA if [OU2] = [InEG]). <p>Minimum distance between ASP and AEP = 25 % of the final value of the measuring range (turn-down 1:4).</p>	ASP AEP

9.4 User settings (optional)

9.4.1 Carry out zero point calibration

<ul style="list-style-type: none">▶ Select [COF] and set a value between -5 % and 5 % of the final value of the measuring range. The internal measured value "0" is shifted by this value.	<i>COF</i>
Alternatively: automatic adjustment of the offset in the range 0 bar \pm 5 %. <ul style="list-style-type: none">▶ Make sure that no pressure is applied to the system.▶ Press [Mode/Enter] until [tCOF] appears.▶ Press and hold down [Set].<ul style="list-style-type: none">> The current offset value (in %) flashes briefly.> The current system pressure is displayed.▶ Release [Set].▶ Briefly press [Mode/Enter] (= to confirm the new offset value).	<i>tCOF</i>

UK

9.4.2 Set output status in fault condition

<ul style="list-style-type: none">▶ Select [FOU1] and set the value:<ul style="list-style-type: none">- [On] = output 1 switches ON in case of a fault.- [OFF] = output 1 switches OFF in case of a fault.- [OU] = output 1 switches irrespective of a fault as defined with the parameters SP1, rP1 and OU1.▶ Select [FOU2] and set the value:<ul style="list-style-type: none">- [On] = output 2 switches ON in case of a fault, the analogue signal goes to the upper final value.- [OFF] = output 2 switches OFF in case of a fault, the analogue signal goes to the lower final value.- [OU] = output 2 switches irrespective of the fault as defined with the parameters SP2, rP2, OU2. The analogue signal corresponds to the measured value.	<i>FOU 1</i> <i>FOU 2</i>
---	------------------------------

Fault indications → 10.3

9.4.3 Set delay time for the switching outputs

<p>[dS1] / [dS2] = switch-on delay for OUT1 / OUT2. [dr1] / [dr2] = switch-off delay for OUT1 / OUT2.</p> <ul style="list-style-type: none">▶ Select [dS1], [dS2], [dr1] or [dr2] and set a value between 0.1 and 50 s (at 0.0 the delay time is not active).	<i>dS 1</i> <i>dr 1</i> <i>dS 2</i> <i>dr 2</i>
---	--

9.4.4 Set output logic for the switching outputs

<ul style="list-style-type: none">▶ Select [P-n] and set [PnP] or [nPN].	<i>P-n</i>
--	------------

9.4.5 Set damping for the switching signal

- ▶ Select [dAP] and set a value between 0.00 and 30.00 s (at 0.00 [dAP] is not active).
- dAP value = response time between pressure change and change of the switching status in seconds.
- [dAP] influences the switching frequency: $f_{\max} = 1 \div 2dAP$.
- [dAP] also has an effect on the display.

dAP

9.4.6 Set damping for the analogue signal

- ▶ Select [dAA] and set a value between 0.01 and 99.99 s (at 0.00 [dAA] is not active).
- dAA value = response time between pressure change and change of the analogue signal in seconds.

dAA

9.4.7 Calibrate curve of measured values

- ▶ Set a defined reference pressure between ASP and AEP in the system.
 - ▶ Select [CAL].
 - ▶ Briefly press [Set].
 - > [CP1] is displayed.
 - ▶ Press [Set] for 5 s.
 - > The pressure measured by the unit is displayed.
 - ▶ Press [Set] until the set reference pressure is indicated (measured pressure = reference pressure) or the corresponding analogue signal is provided on OUT2.
- Maximum correction value = $\pm 2\%$ of the final value of the measuring range.
- ▶ Briefly press [Mode/Enter].
 - > [CP1] is displayed.
 - ▶ Briefly press [Mode/Enter].
 - > [CP2] is displayed.
- Continue with a) or b).

CAL
CP 1

<p>a) Finish calibration:</p> <ul style="list-style-type: none"> ▶ Briefly press [Mode/Enter]. > [CAL] is displayed. <p>b) Change a 2nd point on the curve of measured values:</p> <ul style="list-style-type: none"> ▶ Set a second defined reference pressure in the system. Minimum distance between the calibration points CP1 and CP2 = 5 % of the final value of the measuring range. ▶ Press [Set] for 5 s. > The pressure measured by the unit is displayed. ▶ Press [Set] until the set reference pressure is indicated (measured pressure = reference pressure) or the corresponding analogue signal is provided on OUT2. Maximum correction value = $\pm 2\%$ of the final value of the measuring range. ▶ Briefly press [Mode/Enter]. > [CP2] is displayed. ▶ Briefly press [Mode/Enter]. > [CAL] is displayed, the process is finished. 	<p>CP2</p>
---	------------

9.5 Service functions

9.5.1 Read min/max values for the system pressure

<ul style="list-style-type: none"> ▶ Select [HI] or [LO] and briefly press [Set]. [HI] = maximum value, [LO] = minimum value. <p>Delete memory:</p> <ul style="list-style-type: none"> ▶ Select [HI] or [LO]. ▶ Press and hold down [Set] until [----] is displayed. ▶ Briefly press [Mode/Enter]. 	<p>HI LO</p>
--	------------------

9.5.2 Reset all parameters to factory setting



<ul style="list-style-type: none"> ▶ Select [rES]. ▶ Press and hold down [Set] until [----] is displayed. ▶ Briefly press [Mode/Enter]. <p>We recommend noting down your own settings before carrying out a reset (→ 13 Factory setting).</p>	<p>rES</p>
--	------------

9.6 Simulation function

9.6.1 Open menu level 3 (simulation)

<ul style="list-style-type: none"> ▶ Select [EF] and briefly press [Set] (= to open menu level 2). ▶ Select [SIM] and briefly press [Set] (= to open menu level 3). > [SEL] is displayed. 	<p>EF SIM</p>
---	-------------------

9.6.2 Set simulation value

<p>Output states</p> <p>If [SEL] is active:</p> <ul style="list-style-type: none">▶ Press and hold down [Set] until [OU] is displayed.▶ Briefly press [Mode/Enter].> [S.OU1] is displayed (in 2-wire operation [S.OU2] is displayed).▶ Press [Set] to set the requested value:<ul style="list-style-type: none">- [OPEN] = output 1 not active / open.- [CLOS] = output 1 active / closed.▶ Briefly press [Mode/Enter].> [S.OU2] is displayed.▶ Press [Set] to set the requested value:<ul style="list-style-type: none">• If [OU2] = [Hnc], [Hno], [Fnc] or [Fno] (not in 2-wire operation):<ul style="list-style-type: none">- [OPEN] = output 2 not active / open.- [CLOS] = output 2 active / closed.• If [OU2] = [I] or [InEG]:<ul style="list-style-type: none">- 3.60...21.10 mA in steps of 0.01 mA.▶ Briefly press [Mode/Enter].	
<p>Process value</p> <p>If [SEL] is active:</p> <ul style="list-style-type: none">▶ Press and hold down [Set] until [Proc] is displayed.▶ Briefly press [Mode/Enter].> [S.Pr] is displayed.▶ Press [Set] to set the requested pressure value.▶ Briefly press [Mode/Enter].	

9.6.3 Set time for simulation

<ul style="list-style-type: none">▶ Select [S.TIM] and set the value between 1...60 minutes.	
--	---

9.6.4 Start simulation

<ul style="list-style-type: none">▶ Select [S.ON].▶ Press and hold down [Set] until the display alternately shows [SIM] and the current operation indication. Current operation indication:<ul style="list-style-type: none">- Current system pressure if [SEL] = [OU].- Simulated measured value set in [S.Pr] if [SEL] = [Proc]. <p>After the simulation time has elapsed [S.OFF] is displayed for 2 s, then [SEL].</p>	
<p>Abort simulation:</p> <ul style="list-style-type: none">▶ Briefly press [Mode/Enter] or [Set].> [S.OFF] is displayed for 2 s, then [SEL].	

10 Operation

After power on, the unit is in the Run mode (= normal operating mode). It carries out its measurement and evaluation functions and provides output signals according to the set parameters.

Operation indication → chapter 7 Operating and display elements.

10.1 Read the set parameters

- ▶ Press [Mode/Enter] until the requested parameter is displayed.
- ▶ Briefly press [Set].
- > The unit displays the corresponding parameter value for approx. 15 s. After 15 s it again displays the parameter, then it returns to the Run mode.

10.2 Change the display in the Run mode

- ▶ Press [Set] briefly in the Run mode.
- > The unit displays the current measured value in the selected type of display for approx. 15 s:
 - System pressure in the unit set in Uni.
 - System pressure in % of the set scaling of the analogue output if [OU2] is configured as analogue output.
 - System pressure in % of the final value of the measuring range if [OU2] is configured as switching output.

10.3 Self-diagnostics / fault indications

The unit has many self-diagnostic options.

- It monitors itself automatically during operation.
- It indicates warnings and faults via IO-Link and via display (even if the display is deactivated).
- If a fault is found, the outputs are set according to the setting of the parameters FOU1 and FOU2 (→ 9.4.2).

Display	IO-Link event number	IO-Link PDValid	IO-Link device status Idx 36	Type of fault	Corrective measures
-/*	0x5111	No	2**	Supply voltage too low.	<ul style="list-style-type: none"> ▶ Check / correct the supply voltage. ▶ In 2-wire operation: Check / correct the connected load.
SC1	0x8CB3	Yes	2**	Excessive current switching output 1.	<ul style="list-style-type: none"> ▶ Check switching output 1 for short-circuit or excessive current; remove the fault.
SC2	0x8CB4	Yes	2**	Excessive current switching output 2.	<ul style="list-style-type: none"> ▶ Check switching output 2 for short-circuit or excessive current; remove the fault.
Para	0x1810/ 0x1Fxx	No	2**	Parameter setting fault via IO-Link; setting a parameter outside the permitted area.	<ul style="list-style-type: none"> ▶ Define parameter via the IO-Link event number 0x1Fxx. ▶ Change parameter via IO-Link or setting buttons. ▶ Reset all parameters to factory setting (→ 9.5.2).
OL	0x8C10	Yes	2**	Process value too high.	<ul style="list-style-type: none"> ▶ Check / reduce system pressure.
UL	0x8C30	Yes	2**	Process value too low.	<ul style="list-style-type: none"> ▶ Check / increase system pressure.
E100	0x5000	No	4**	Internal sensor fault detected.	<ul style="list-style-type: none"> ▶ Replace the unit.
W531	0x8CA1	Yes	2**	Analogue output at the upper limit (20.5 mA).	<ul style="list-style-type: none"> ▶ Increase AEP value if possible (if [OU2] = [InEG] ASP value) or reduce system pressure.

Display	IO-Link event number	IO-Link PDValid	IO-Link device status Idx 36	Type of fault	Corrective measures
W530	0x8CA0	Yes	2**	Analogue output at the lower limit (3.8 mA).	► Reduce ASP value if possible (if [OU2] = [InEG] AEP value) or increase system pressure.
W532	0x8CA5	Yes	2**	Load at analogue output too high.***	► Reduce load at output 2 or increase the supply voltage.
W203	0x1822	Yes	2**	Fault during the temperature compensation of the pressure measurement.	The unit uses a higher temperature coefficient (i.e. with reduced accuracy). ► Replace the unit.
W703	0x8CC2	Yes	2**	Sensor temperature too high.	Reduce temperature.
W704	0x8CC3	Yes	2**	Sensor temperature too low.	Increase temperature.
W161	0x4210	Yes	2**	Unit temperature too high (> 90 °C).	Unit outside the specification. ► Do not insulate the installation.
W162	0x4220	Yes	2**	Unit temperature too low (< -30 °C).	Unit outside the specification. ► Insulate the installation.

* In case of undervoltage (fault no. W403) nothing is displayed.

** 2 = out of spec, 4 = failure

*** This message is only displayed for 3-wire operation. For 2-wire operation undervoltage is detected and displayed. If OU2 is not used for the application, the message can be suppressed by defining a switching function for OU2 (→ 9.3.1).

11 Technical data

11.1 Setting ranges

		SP1 / SP2		rP1 / rP2		ASP		AEP		ΔP
		min	max	min	max	min	max	min	max	
PI2xx3	bar	-0.96	25.00	-1.00	24.96	-1.00	18.74	5.24	25.00	0.02
	PSI	-13.8	362.7	-14.4	362.1	-14.4	271.8	76.2	362.7	0.3
	MPa	-0.096	2.500	-0.100	2.496	-0.100	1.874	0.524	2.500	0.002
PI2xx4	bar	-0.98	10.00	-1.00	9.98	-1.00	7.50	1.50	10.00	0.01
	PSI	-14.2	145.0	-14.5	144.7	-14.5	108.7	21.8	145.0	0.1
	MPa	-0.098	1.000	-0.100	0.998	-0.100	0.750	0.150	1.000	0.001
PI2xx5	bar	-0.990	4.000	-1.000	3.990	-1.000	3.000	0.000	4.000	0.005
	PSI	-14.35	58.00	-14.50	57.85	-14.50	43.50	0.00	58.00	0.05
	kPa	-99.0	400.0	-100.0	399.0	-100.0	300.0	0.0	400.0	0.5
PI2xx6	bar	-0.120	2.500	-0.124	2.496	-0.124	1.880	0.500	2.500	0.002
	PSI	-1.74	36.27	-1.80	36.21	-1.80	27.27	7.26	36.27	0.03
	kPa	-12.0	250.0	-12.4	249.6	-12.4	188.0	50.0	250.0	0.2
	inH ₂ O	-48	1004	-50	1002	-50	755	201	1004	1
	mWS	-1.22	25.49	-1.26	25.45	-1.26	19.17	5.10	25.49	0.01
PI2xx7	mbar	-48	1000	-50	998	-50	750	200	1000	1
	PSI	-0.70	14.50	-0.73	14.47	-0.73	10.88	2.90	14.50	0.01
	kPa	-4.8	100.0	-5.0	99.8	-5.0	75.0	20.0	100.0	0.1
	inH ₂ O	-19.2	401.6	-20.0	400.8	-20.0	301.2	80.4	401.6	0.4
	mWS	-0.49	10.20	-0.51	10.18	-0.51	7.65	2.04	10.20	0.01
PI2xx9	mbar	-998	1000	-1000	998	-1000	500	-500	1000	1
	PSI	-14.45	14.50	-14.50	14.45	-14.50	7.25	-7.25	14.50	0.05
	kPa	-99.8	100.0	-100.0	99.8	-100.0	50.0	-50.0	100.0	0.1
	inH ₂ O	-400	401	-401	400	-401	201	-201	401	1
	mWS	-10.18	10.20	-10.20	10.18	-10.20	5.10	-5.10	10.20	0.01

ΔP = step increment

11.2 Technical data

Further technical data and scale drawing at www.ifm.com.

12 Factory setting

	Factory setting	User setting
SP1	25% VMR*	
rP1	23 % VMR*	
OU1	Hno	
OU2	I	
SP2	75 % VMR*	
rP2	73 % VMR*	
COF / tCOF	0.0	
ASP / tASP	0 % VMR* PI2209: -1 bar	
AEP / tAEP	100 % VMR*	
Uni	bAr / mbAr	
SELd	P	
dS1	0.0	
dr1	0.0	
dS2	0.0	
dr2	0.0	
FOU1	OUT	
FOU2	OUT	
P-n	pnP	
dAP	0.06	
dAA	0.03	
dis	d2	
CP1	0.00	
CP2	0.00	

* = The indicated percentage of the final value of the measuring range (VMR) of the respective sensor (for PI2x09 the percentage of the measuring span) is set.

More information at www.ifm.com