



Operating instructions
Electronic level sensor

UK

LR2350

80255869 / 02 01 / 2022

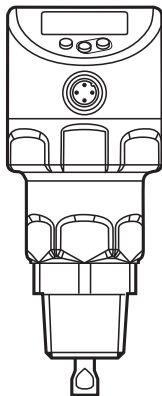

Contents

1	Preliminary note	5
1.1	Symbols used	5
2	Safety instructions	5
3	Items supplied	6
4	Getting started	6
5	Functions and features	7
5.1	Applications	7
5.2	Restriction of the application area	7
6	Function	8
6.1	Measuring principle	8
6.2	Outputs	9
6.3	Other features of the unit	9
6.3.1	Display functions	9
6.3.2	Analogue function	10
6.3.3	Switching functions	12
6.3.4	Damping function	13
6.3.5	Probes for different tank heights	13
6.3.6	Defined state in case of a fault	13
6.3.7	IO-Link	14
6.3.8	Simulation functions	14
7	Installation	14
7.1	Installation location / environment	14
7.1.1	Minimum distances for installation in closed metal tanks	15
7.1.2	Installation in pipes	15
7.1.3	Applications with viscous and fast flowing media	16
7.1.4	Fill openings	16
7.1.5	Heavy soiling	17
7.1.6	Heavy foam build-up and turbulence	17
7.1.7	Notes on tank adjustment	18
7.2	Installation of the probe	19
7.3	Probe length	20
7.3.1	Shorten the probe	20
7.3.2	Determine probe length L	20

7.4	Installation of the unit.....	21
7.4.1	Installation to 3/4 NPT process connection directly in the tank lid.....	21
7.4.2	Installation in the tank lid using a 3/4 NPT flange plate	22
7.4.3	Installation in open metal tanks	23
7.4.4	Installation in plastic tanks.....	24
7.5	Alignment of the sensor housing	25
8	Electrical connection.....	26
9	Operating and display elements	27
10	Menu.....	28
10.1	Menu structure.....	28
10.2	Explanation of the menu	30
10.2.1	Main menu [I].....	30
10.2.2	EF level (extended functions) [II].....	30
10.2.3	CFG level (configuration) [III].....	31
10.2.4	ENV level (environment) [IV]	31
10.2.5	SIM level (simulation) [V].....	31
11	Parameter setting.....	32
11.1	Parameter setting in general.....	32
11.2	Basic settings (set-up)	34
11.2.1	Enter probe length	34
11.2.2	Setting to the medium.....	34
11.2.3	Carry out tank adjustment.....	35
11.3	Configure display (optional)	35
11.4	Set output signals	36
11.4.1	Set output function for OUT 1	36
11.4.2	Set switching limits (hysteresis function)	36
11.4.3	Set switching limits (window function)	36
11.4.4	Set switch-on delay for switching outputs.....	36
11.4.5	Set switch-off delay for switching outputs.....	36
11.4.6	Set output function for OUT2.....	37
11.4.7	Scale analogue signal.....	37
11.4.8	Set output logic for switching outputs	37
11.4.9	Set response of the outputs in case of a fault.....	37
11.4.10	Set damping for the measured signal	37
11.4.11	Set delay time in case of a fault	38
11.5	Reset all parameters to factory setting	38

11.6	Change basic settings.....	38
11.6.1	Re-enter probe length.....	38
11.6.2	Set to another medium	38
11.7	Simulation	39
11.7.1	Set simulation value.....	39
11.7.2	Set simulation time	39
11.7.3	Switch simulation on / off	39
12	Operation.....	40
12.1	Single probe	40
12.2	Function check	40
12.3	Operation indication.....	41
12.4	Read the set parameters	41
12.5	Change the display unit in the operating mode	41
12.6	Error indications.....	42
12.7	Output response in different operating states.....	43
13	Technical data.....	43
14	Maintenance / transport.....	44
15	Factory setting	45
16	Notes on parameter setting via IO-Link.....	46
16.1	Application example.....	46
16.2	Unit locking / data storage (as from IO-Link V1.1).....	47

1 Preliminary note

1.1 Symbols used

- ▶ Instructions
- > Reaction, result
- [...] Designation of keys, buttons or indications
- Cross-reference



Important note

Non-compliance may result in malfunction or interference.



Information

Supplementary note.

2 Safety instructions

- The device described is a subcomponent for integration into a system.
 - The system architect is responsible for the safety of the system.
 - The system architect undertakes to perform a risk assessment and to create documentation in accordance with legal and normative requirements to be provided to the operator and user of the system. This documentation must contain all necessary information and safety instructions for the operator, the user and, if applicable, for any service personnel authorised by the architect of the system.
- Read this document before setting up the product and keep it during the entire service life.
- The product must be suitable for the corresponding applications and environmental conditions without any restrictions.
- Only use the product for its intended purpose (→ Functions and features).
- Only use the product for permissible media (→ Technical data).
- If the operating instructions or the technical data are not adhered to, personal injury and/or damage to property may occur.
- The manufacturer assumes no liability or warranty for any consequences caused by tampering with the product or incorrect use by the operator.
- Installation, electrical connection, set-up, operation and maintenance of the product must be carried out by qualified personnel authorised by the machine operator.
- Protect units and cables against damage.

3 Items supplied

- LR2350 level sensor
- 1 operating instructions

In addition, the following is necessary for installation and operation (→ Accessories):

- 1 probe (→ 12.1)
- mounting material (if necessary, a launching plate (→ 12.1))
- ▶ In the event of incomplete or damaged items supplied please contact ifm electronic.



- ▶ Only use accessories from ifm electronic.

Accessories: www.ifm.com

The optimum function is not ensured when using components from other manufacturers.

4 Getting started

For the most frequent applications the quick set-up described below is possible. The quick set-up does not replace observance of the other chapters.

- ▶ Install the unit correctly:
Installation distances (→ 7.1), Electrical connection (→ 8).
- ▶ Setting the probe length and medium (→ 11.2).
- > The unit is ready for operation.



Without changes = factory settings active (→ 15)

Change of the factory settings (→ 11).

- ▶ As an option, carry out a tank adjustment (→ 11.2.3).
- ▶ If necessary, make more settings for adaptation to the application (→ 11.3) and (→ 11.4).
- ▶ Check whether the unit operates correctly.

5 Functions and features

The unit continuously detects the level in tanks.

5.1 Applications

- Water, water-based media
- Compatible with 3/4 NPT process connections

Application examples:

- Detection of cleaning liquid in a parts cleaning system
- Detection of cooling water in an industrial cooling system
- Detection of hot glue in corrugated cardboard manufacture

The unit complies with the standard EN 61000-6-4 and is a class A product. The unit may cause radio interference in domestic areas. If interference occurs, the user must take appropriate actions.



The microwave energy radiated by the unit is much below that of mobile phones.

According to the current state of science the operation of the unit can be classified to be harmless to human health.

5.2 Restriction of the application area



Incorrect measurements may be caused by the following media:

- Highly absorbing surfaces (e.g. foam).
- Intensely bubbling surfaces.
- Media which are very inhomogeneous, separate from each other thus forming separation layers (e.g. oil layer on water).
 - ▶ Check the function by performing an application test.
 - ▶ Installation in a steady area (→ 7.1.6).
 - > In case of signal loss, the unit displays [SEnS] and switches the outputs to a defined state (→ 12.7).
- The unit is not suitable for bulk materials (e.g. plastic granulates) and media with a very low dielectric constant (e.g. oils).

- The unit is not suitable for applications where the probe is subjected to permanent and high mechanical stress (e.g. heavy movement of viscous media or fast flowing media).
- Use preferably in metal tanks. When used in plastic tanks, deterioration caused by electromagnetic interference may occur (noise immunity to EN61000-6-2). Corrective measures (→ 7.4.4)
- When operating with a single probe and small tanks (probe lengths shorter than 200 mm and less than 300 mm distance to the tank wall), interference from the tank (resonances) may occur in rare cases. Corrective measures: (→ 7.1)
- Not suited for operation with coaxial probe.

6 Function

6.1 Measuring principle

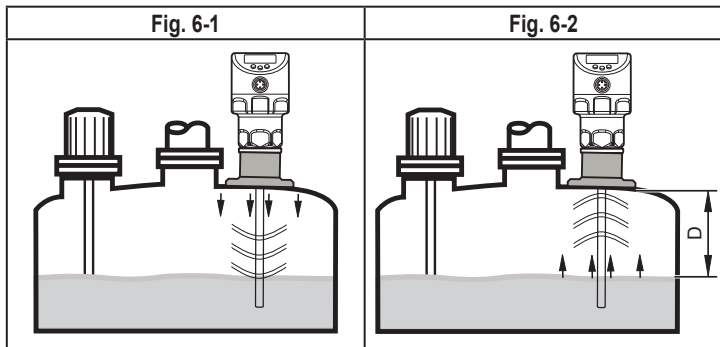

The unit operates on the principle of guided wave radar. It measures the level using electromagnetic pulses in the nanosecond range.

The pulses are transmitted by the sensor head and guided along the probe (Fig. 6-1). When they hit the medium to be detected, they are reflected and guided back to the sensor (Fig. 6-2). The time between transmitting and receiving the pulse directly relates to the travelled distance (D) and the current level. The reference for distance measurement is the lower edge of the process connection.

6.2 Outputs

The unit generates output signals according to the parameter setting. 2 outputs are available. They can be set separately.

OUT1	switching signal for level limit / IO-Link (→ 6.3.7)
OUT2	<ul style="list-style-type: none">• analogue signal proportional to level 4...20 mA / 20...4 mAor• switching signal for level limit

6.3 Other features of the unit

- Increased temperature range, increased protection rating (→ Technical data sheet)
- Special operating mode for media with increased foam build-up (→ 11.2.2)
- Tank adjustment enables suppression of undesired interference (e.g. caused by structures in the tank or when mounted in a connection piece (→ 11.2.3))
- Display of the level and the switching status via display / LEDs
- IO-Link function (→ 6.3.7)

6.3.1 Display functions

The unit displays the current level, either in mm, inch or in percent of the scaled measuring range. Factory setting: inch.

The display unit is defined by programming (→ 11.3).

In the operating mode, the user can switch between the length display (mm / inch) and percentage (→ 12.5).

The set unit of measurement and the switching status of the outputs are indicated by LEDs (→ 9).

6.3.2 Analogue function

The unit provides an analogue signal proportional to level.

The analogue output (OUT2) can be set (→ 11.4.6 and the following figures).

- [ou2] defines the output function of the analogue output:
 - current output rising ([ou2] = [I]) or
 - current output falling ([ou2] = [InEG])
 - The analogue start point [ASP2] defines at which measured value the analogue start value* is provided (→ 11.4.7).
- The analogue end point [AEP2] defines at which measured value the analogue end value* is provided (→ 11.4.7).

*) The analogue start value is 4 mA with [ou2] = [I] or 20 mA with [ou2] = [InEG].

The analogue end value is 20 mA with [ou2] = [I] or 4 mA with [ou2] = [InEG].

Minimum distance between [ASP2] and [AEP2] = 20 % of the active zone.

Curve of the analogue signal (factory setting):

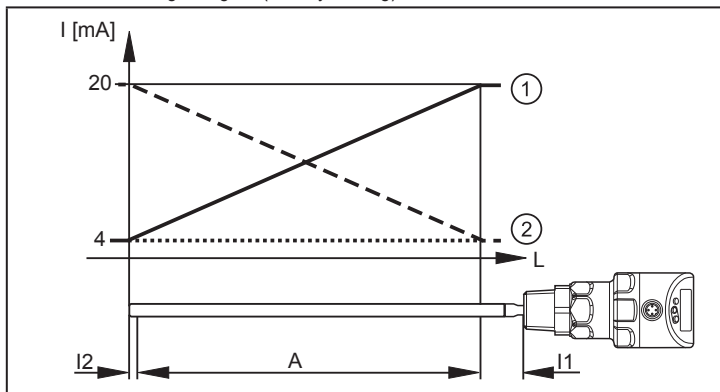

Curve of the analogue signal (measuring range scaled):

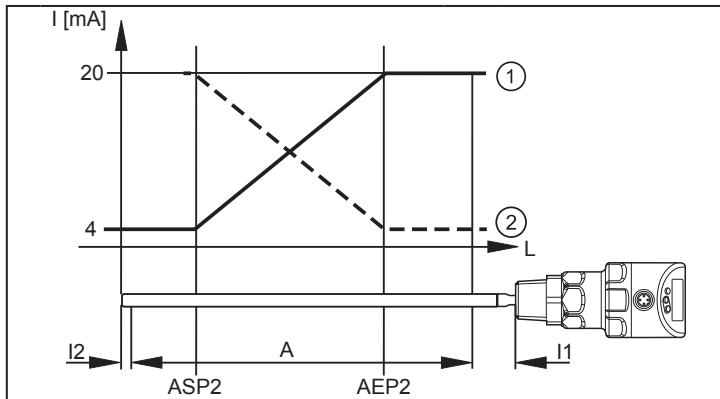

L: level

A: active zone = probe length $L - (l_1 + l_2)$

l_1 : inactive zone 1

l_2 : inactive zone 2 (→ Technical data sheet)

①: $[ou_2] = I$ (factory setting)

②: $[ou_2] = [InEG]$

ASP2: analogue start point

AEP2: analogue end point

Additional information about the analogue output (→ 12.7)

Note the tolerances and accuracies during the evaluation of the analogue signal (→ Technical data sheet).

6.3.3 Switching functions

Via switching output OUT1 (factory setting) or additionally via OUT2 (can be set) the unit signals that a set limit level has been reached or that the level is below the limit. The following switching functions can be selected:

- Hysteresis function / normally open (Fig. 6-3): [oux] = [Hno]
- Hysteresis function / normally closed (Fig. 6-3): [oux] = [Hnc]



First the set point [SPx] is set, then the reset point [rPx] with the requested difference.

- Window function / normally open (Fig. 6-4): [oux] = [Fno]
- Window function / normally closed (Fig. 6-4): [oux] = [Fnc]



The width of the window can be set by means of the difference between [FHx] and [FLx]. [FHx] = upper value, [FLx] = lower value.

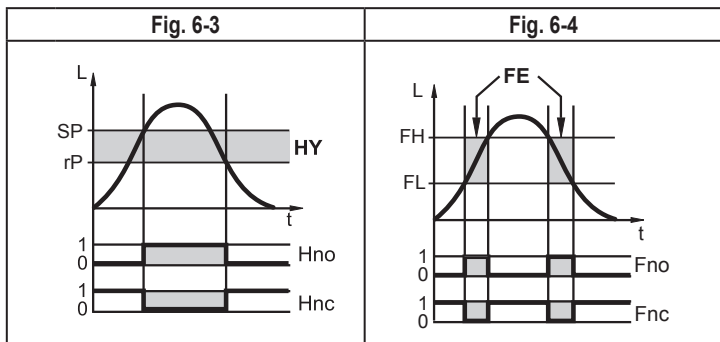

L: level

HY: hysteresis

FE: window

- The limits to be set (e.g. [SP] / [rP1]) always refer to the lower edge of the probe.
- For the switching output a switch-on and switch-off delay of max. 60 s can be set (e.g. for especially long pump cycles) (→ 11.4.4).

6.3.4 Damping function

With unsteady level (e.g. turbulence, wave movements) display and output response can be damped. During damping the determined level values are "smoothed" by means of a mean filter; the result is a steady curve. Damping can be set by means of the parameter [dAP] (→ 11.4.10).

[dAP] indicates in seconds after what time 63 % of the final value is reached in the event of a sudden jump. After 5 x [dAP] almost 100 % has been reached.

6.3.5 Probes for different tank heights

- The unit can be installed in tanks of different sizes. Probes in different lengths are available. To adapt to the tank height, each probe can be shortened. The minimum probe length is 150 mm, the maximum probe length 2000 mm.
- For ease of installation and removal the probe connection can be rotated without restriction.

6.3.6 Defined state in case of a fault

- In case of a fault a state can be defined for each output.
- If a fault is detected or if the signal quality is below a minimum value, the outputs pass into a defined state, according to NAMUR recommendation in case of the analogue output.

For this case the response of the outputs can be set via the parameters [FOU1], [FOU2] (→ 11.4.9).

- Temporary loss of signal caused e.g. by turbulence or foam build-up can be suppressed by a delay time (parameter [dFo] (→ 11.4.11)). During the delay time the last measured value is frozen. If the measured signal is received again in sufficient strength within the delay time, the unit continues to work in normal operation. If, however, it is not received again in sufficient strength within the delay time, the outputs pass into the defined state.



In case of heavy foam build-up and turbulence, note the examples of how to create a steady area (→ 7.1.6).

6.3.7 IO-Link

This unit has an IO-Link communication interface which requires an IO-Link capable module (IO-Link master) for operation.

The IO-Link interface enables direct access to the process and diagnostic data and provides the possibility to set the parameters of the unit during operation.

In addition, communication is possible via a point-to-point connection with a USB IO-Link master.

The IODDs necessary for the configuration of the unit, detailed information about process data structure, diagnostic information, parameter addresses and the necessary information about the required IO-Link hardware and software can be found at www.ifm.com.

6.3.8 Simulation functions

Various levels and errors can be simulated for set-up, maintenance or interference reduction. The duration of the simulation can be selected (1 min...1 h). The simulation can be started manually and runs until it is stopped manually or the set time elapses. During the simulation the outputs respond according to the simulated process values (→ 11.7).

7 Installation

7.1 Installation location / environment

- Vertical installation from the top is preferred.
- ▶ Observe the notes on tank adjustment (→ 7.1.7).
- For installation in open tanks (→ 7.4.3)
- For installation in plastic tanks (→ 7.4.4)
- When operating the unit in small tanks (probe lengths shorter than 200 mm and less than 300 mm distance to the tank wall), mount the unit off-centre (eccentrically) to prevent possible interference from tank resonances.

7.1.1 Minimum distances for installation in closed metal tanks

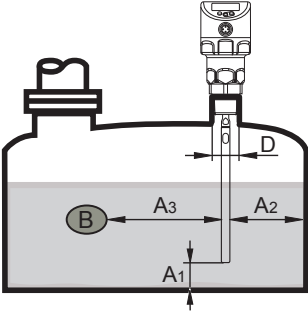
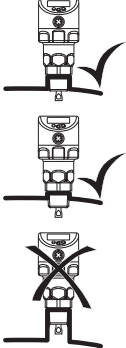
Fig. 7-1	Fig. 7-2
 <p>The diagram shows a cross-section of a tank with a liquid level. A probe is installed vertically. Dimension A1 is the distance from the tank bottom to the probe's sensor. Dimension A2 is the distance from the probe's sensor to the tank wall. Dimension A3 is the distance from the probe's sensor to a structure labeled B. Dimension D is the diameter of the probe. The probe is connected to a unit on top of the tank.</p>	<p>Without adjustment</p>  <p>The three diagrams show different installation scenarios. The first two show the probe correctly installed with a connection piece, marked with checkmarks. The third shows the probe installed without a connection piece, marked with a large 'X'.</p>
Installation distances with adjustment (→ 7.1.7)	Installation distances without adjustment
A1: 10 mm *)	A1: 10 mm *)
A2: 20 mm	A2: 50 mm
A3: 20 mm to structures in the tank (B) 50 mm to other sensors type LR	A3: 50 mm to structures in the tank (B) 50 mm to other sensors type LR
D: Ø 30 mm if installed in a connection piece	D: No connection piece allowed according to Fig. 7-2

*) Alternatively: Fix probe at the tank bottom. Observe notes (→ 7.1.3).

7.1.2 Installation in pipes

► The internal pipe diameter d must at least have the following value:

d	With adjustment(→ 7.1.7)	Without adjustment
Metal pipe	Ø 30 mm	Ø 100 mm with [MEdl] = [HIGH] Ø 200 mm with [MEdl] = [Mid] (→ 11.2.2)
Plastic pipe *)	Ø 200 mm	

*) Observe notes (→ 7.4.4)

► If possible, mount the unit off-centre (eccentrically).



Depending on the operating conditions (flow) and mechanical design of the pipe the use of centring pieces is recommended (→ Accessories).

7.1.3 Applications with viscous and fast flowing media

- ▶ If possible, install the unit in a bypass pipe / still pipe (→ 7.1.2).
- ▶ In addition, the following aspects have to be considered:
 - ▶ Probe must not be in contact with the tank wall / structures.
 - ▶ Increase lateral minimum distances according to the probe length and the lateral deflection to be expected.
 - ▶ If possible, fix the probe at the tank bottom so that it is electrically conductive. This can be done by means of a sleeve or similar devices (Fig. 7-3).
 - ▶ Check the correct function (in particular with empty tank).

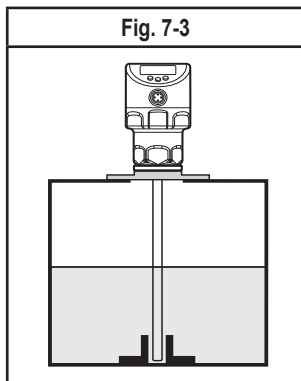

7.1.4 Fill openings

Do not install the unit in the immediate vicinity of a fill opening (Fig. 7-4). If possible, install a fill pipe (A) in the tank (Fig. 7-5). Keep to the indicated installation distances; if necessary, carry out a tank adjustment.

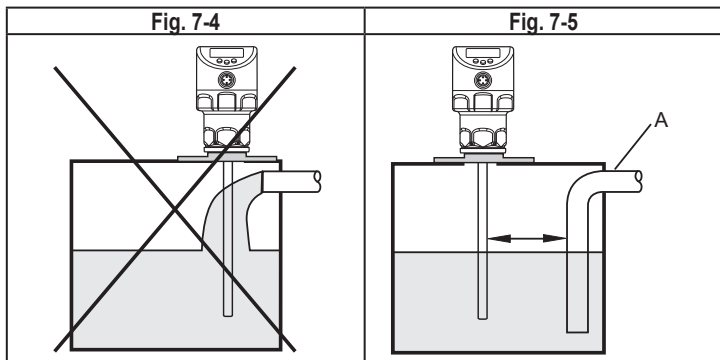

7.1.5 Heavy soiling

If the medium is highly polluted, there is the risk that a bridge forms between the probe and the tank wall or structures in the tank.

- ▶ Increase minimum distances depending on the pollution intensity.

7.1.6 Heavy foam build-up and turbulence

! Heavy foam build-up and turbulence may lead to incorrect measurements.

To avoid this

- ▶ Install the sensor in a steady area.

Examples how to create a steady area:

- Installation in metal bypass or metal still pipe (Fig. 7-6).
- Separation of the installation location by metal sheets / perforated sheets (without figure).

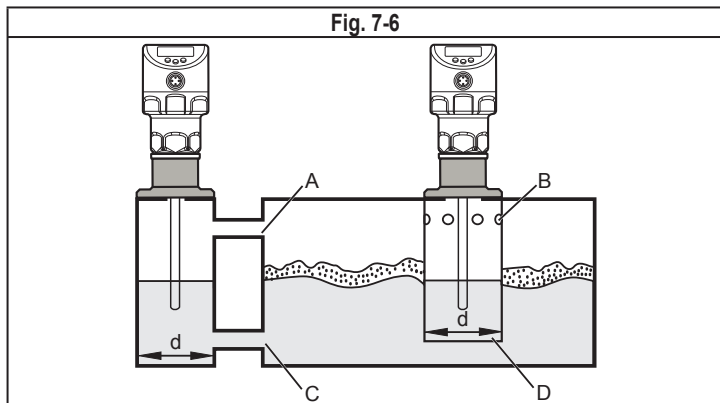

! The upper access to the steady area (A, B) must be above the max. level. The lower access (C, D) or the area with perforated sheet must be below the min. level. This ensures that neither foam nor turbulence impact the sensor zone. When perforated sheets or similar are used, soiling (e.g. solids in the medium) can also be avoided.

i With increased foam build-up the setting [MEdl] = [Mld] is recommended (→ 11.2.2).

7.1.7 Notes on tank adjustment



Tank adjustment [tREF] reduces the effect of interference and ensures a higher excess gain in difficult application conditions.



Carry out the tank adjustment only when the unit is installed.

For the tank adjustment it is necessary to enter an "adjustment distance" first. Within this distance, starting from the process connection, interfering reflections are compensated.

- ▶ Select an adjustment distance (a) so that the connection piece (S) and structures in the tank (B) are completely detected.
- ▶ Observe safety distance ($b \geq 250$ mm) to the level or the end of the probe.

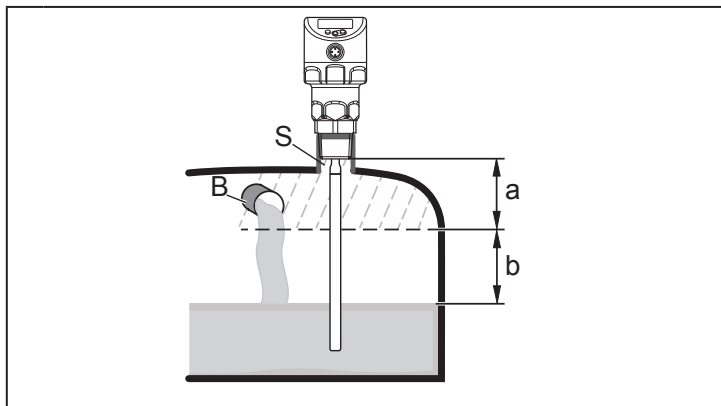

a: adjustment distance (min: 10 mm; max: $L - 250$ mm)

b: safety distance to the level or the end of the probe: $b \geq 250$ mm

S: connection piece

B: structures in the tank



For probe lengths $L < 260$ mm no tank adjustment is possible. The parameter [tREF] is then not available. In this case:

- ▶ Adhere to all indicated installation distances (\rightarrow 7.1).



No tank adjustment is necessary if all installation distances (\rightarrow 7.1) are adhered to. The unit is then ready for operation without tank adjustment.

- ▶ In case of doubt carry out a tank adjustment (recommended!).



Carry out a tank adjustment with empty tank, if possible, to detect any possible sources of interference. In this case:

- ▶ Select the max. adjustment distance (L - 250 mm).



Only if data storage is required in an IO-Link application:

The tank adjustment is not saved via IO-Link. After a replacement it must be carried out again.

More information about data storage (→ 16.2).

7.2 Installation of the probe

The probe is not supplied. It has to be ordered separately (→ 3 Items supplied).

Fixing of the probe:

- ▶ Screw the probe to the unit and tighten it.



Recommended tightening torque: 4 Nm.

For ease of installation and removal the probe connection can be rotated without restriction. Even if rotated several times, there is no risk of damage to the unit.

In case of high mechanical stress (strong vibration, moving viscous media) it may be necessary to secure the screw connection, e.g. by a screw retaining compound.

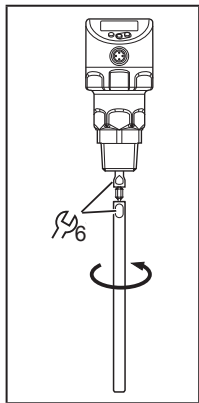

Substances such as screw retaining compounds may migrate into the medium.

- ▶ Make sure that they are harmless.

When using mechanical means of securing (e.g. tooth lock washer):

- ▶ Avoid protruding edges. They may cause interference reflection

7.3 Probe length

7.3.1 Shorten the probe

The probe can be shortened to adapt to different tank heights.

 Ensure that the probe length is not below the minimum permissible probe length (L_{\min}) of 150 mm. The unit does not support probe lengths below 150 mm.

 For probe lengths < 260 mm no tank adjustment is possible (→ 7.1.7).

Proceed as follows:

- ▶ Screw the probe to the unit.
- ▶ Mark the desired length (L) on the probe. The reference point is the lower edge of the process connection (Fig. 7-7).
- ▶ Remove the probe from the unit.
- ▶ Shorten the probe at the mark.
- ▶ Remove all burrs and sharp edges.
- ▶ Screw the probe to the unit again and tighten it (→ 7.2).

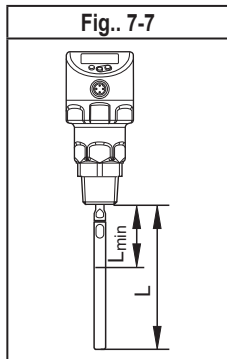

7.3.2 Determine probe length L

- ▶ Precisely measure the probe length L . The reference point is the lower edge of the process connection (Fig. 7-7).
- ▶ Note the value. It is needed for setting the device parameters (→ 11.2).

7.4 Installation of the unit

- !** Before installing and removing the unit: Make sure that no pressure is applied to the system and that there is no medium in the tank that could leak. Also always take into account the potential dangers related to extreme machine and medium temperatures.

For installation in closed metal tanks, the tank lid serves as a launching plate R (Fig. 7-8 and 7-10). Notes (→ 12.1).

Options are as follows:

- Installation to 3/4 NPT process connection directly in the tank lid (→ 7.4.1).
- Installation in the tank lid using a flange plate (e.g. for tanks with thin walls) (→ 7.4.2).

- i** During installation of the process connection on the tank lid observe the subsequent orientation of the housing (display orientation, cable outlet). The sensor housing cannot be rotated with respect to the internal thread! Subsequent alignment of the sensor housing is therefore not possible.

Furthermore, installation in open tanks (→ 7.4.3) and plastic tanks is possible (→ 7.4.4).

7.4.1 Installation to 3/4 NPT process connection directly in the tank lid

- ▶ Apply a suitable sealing material (e.g. PTFE tape) to the sensor thread.

If no sealing material is used:

- ▶ Lightly grease the sensor thread with a suitable paste.
- ▶ Insert the unit into the process connection.
- ▶ Tighten it using a spanner. Tightening torque: 35 Nm.

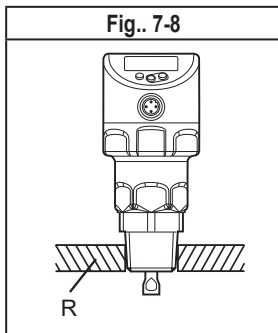

7.4.2 Installation in the tank lid using a 3/4 NPT flange plate

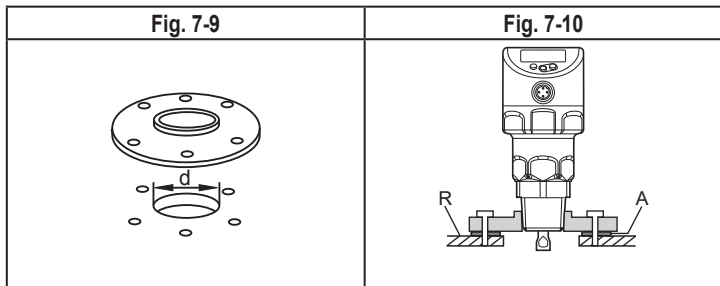

- ▶ Arrange for a bore hole in the tank lid. It must have a minimum diameter (d) to enable sufficient transfer of the measured signal to the probe (Fig. 7-9). The diameter (d) depends on the wall thickness of the tank lid:

Wall thickness [mm]	1...5	5...8	8...11
d [mm]	35	45	55

- ▶ Install the flange plate with 3/4 NPT process connection with the flat surface showing to the tank and fix it with appropriate screws.

! If necessary, a seal (A in Fig. 7-10) can be inserted between flange plate and tank. Some flange plates are supplied with a seal. If this is not the case, use a suitable seal.

- ▶ Ensure cleanliness and evenness of the sealing areas; especially if the tank is under pressure. Tighten the fixing screws sufficiently.
- ▶ Apply a suitable sealing material (e.g. PTFE tape) to the sensor thread.

If no sealing material is used:

- ▶ Lightly grease the sensor thread with a suitable paste.
- ▶ Insert the unit into the process connection.
- ▶ Tighten it using a spanner. Tightening torque: 35 Nm.

7.4.3 Installation in open metal tanks

- ▶ For installation in open metal tanks, use a metal fixture with 3/4 NPT process connection to install the unit. It serves as a launching plate (R; minimum size: 150 x 150 mm for a square fixture, 150 mm diameter for a circular fixture (→ 12.1)).
- ▶ If possible, mount the unit in the middle of the fixture. Adhere to the specified installation distances according to (→ 7.1); if necessary, carry out a tank adjustment.

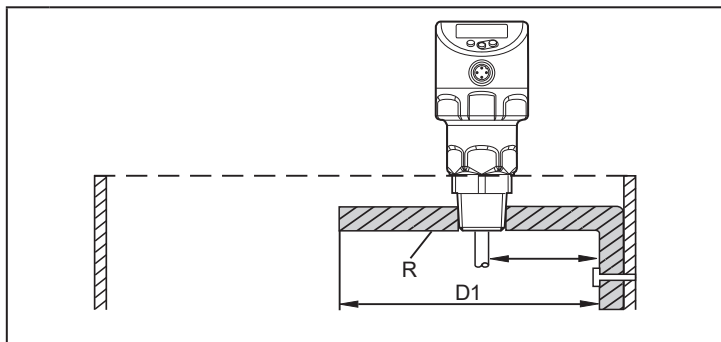

D1 min. 150 mm
R: launching plate

- ▶ Lightly grease the sensor thread with a suitable paste.
- ▶ Insert the unit into the process connection.
- ▶ Tighten it using a spanner. Tightening torque: 35 Nm.

7.4.4 Installation in plastic tanks

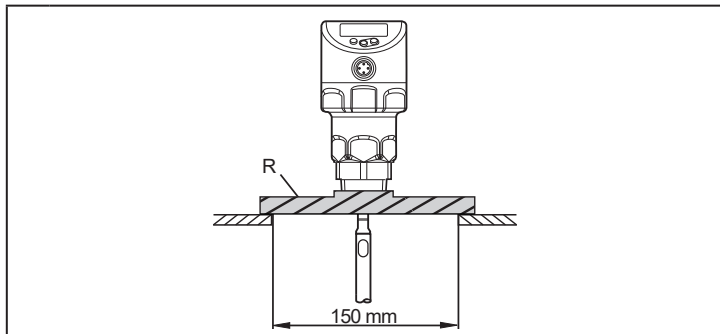

R: launching plate

To enable sufficient transfer of the measured signal, note in case of installation in plastic tanks or metal tanks with plastic lid:

- ▶ The plastic lid must be provided with a drill hole with a minimum diameter of 150 mm.
- ▶ For installation of the unit, a metal flange plate (launching plate, R) with 3/4 NPT process connection must be used which sufficiently covers the drill hole (→ 12.1).
- ▶ Ensure a minimum distance (= 80 mm) between the probe and the tank wall. Adhere to the specified installation instructions according to (→ 7.1); if necessary, carry out tank adjustment.



When installed in plastic tanks, there may be deterioration caused by electromagnetic interference from other devices. Possible remedies:

- Attach a large-surface, metal screen at the outside of the tank. Check grounding concept; if necessary, change.
 - Eliminate sources of interference or reduce emissions from the source of interference taking electro-technical measures.
 - Installation in a metal pipe in the plastic tank.
- ▶ Lightly grease the sensor thread with a suitable paste.
 - ▶ Insert the unit into the process connection.
 - ▶ Tighten it using a spanner. Tightening torque: 35 Nm.

7.5 Alignment of the sensor housing



The sensor housing cannot be rotated with respect to the internal thread! Subsequent alignment of the sensor housing is therefore **not** possible.

Therefore, the subsequent orientation of the housing (display orientation, cable outlet) must be observed during installation of the process connection on the tank lid.

8 Electrical connection



The unit must be connected by a qualified electrician.

The national and international regulations for the installation of electrical equipment must be adhered to.

Voltage supply according to SELV, PELV.



For marine applications (if approval available for the device), additional surge protection is required.

► Disconnect power.

► Connect the unit as follows:

Core colours			
BK	black		
BN	brown		
BU	blue		
WH	white		
		OUT1: switching output / IO-Link	
		OUT2: analogue output or switching output	
		colours to DIN EN 60947-5-2	
Example circuits			
2 x positive switching		2 x negative switching	
1 x positive switching / 1 x analogue		1 x negative switching / 1 x analogue	



When operating voltage is applied to the unit for the first time, the basic settings must be entered first (→ 11.2). Only then is the unit ready for operation.

9 Operating and display elements

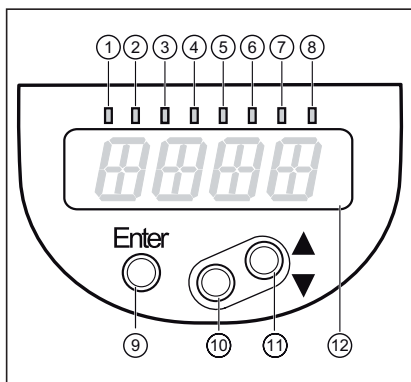

1 to 8: Indicator LEDs	
LEDs 1 - 3	Selected unit of measurement.
LEDs 4 - 6	Not used.
LEDs 7 - 6	Only active if the switching output [ou2] = [I] or [InEG] is selected; then: switching status OUT2 (on when output 2 is switched).
LED 8	Switching status OUT1 (on when output 1 is switched).
9: [Enter] button	
<ul style="list-style-type: none"> - Open the user menu. - Edit and confirm the parameter values. 	
10 to 11: Arrow keys up [▲] and down [▼]	
<ul style="list-style-type: none"> - Selection of the parameters. - Setting of the parameter values (continuously by holding pressed; incrementally by pressing once). 	
12: Alphanumeric display, 4 digits	
<ul style="list-style-type: none"> - Display of the current level. - Display of the parameters and parameter values. 	

10 Menu

10.1 Menu structure

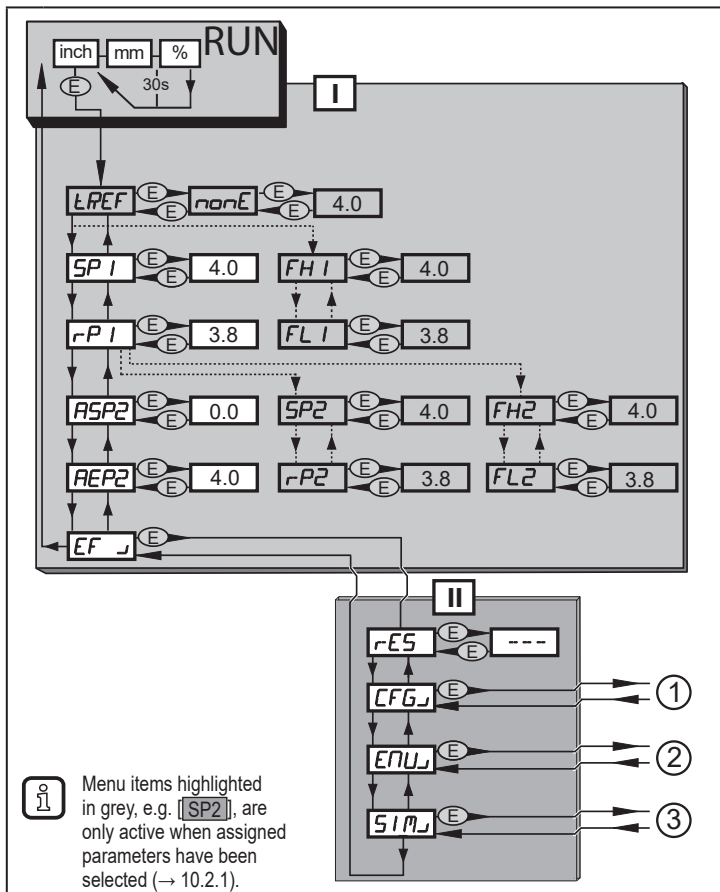

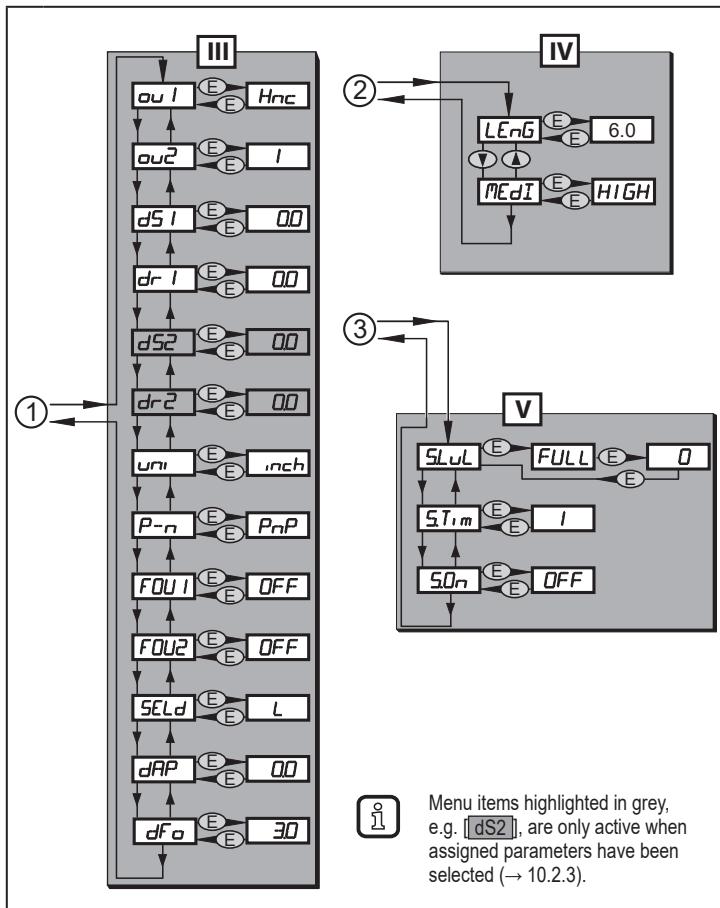

III : CFG level (→ 10.2.3)

IV : ENV level (→ 10.2.4)

V : SIM level (→ 10.2.5)

10.2 Explanation of the menu

10.2.1 Main menu [I]

tREF	Carry out tank adjustment. Menu item only visible if [LEnG] ≥ 260 mm.
SP1 / rP1	Set point 1 / reset point at which OUT1 switches. Menu item only visible if hysteresis function is selected ([ou1] = [H..]).
FH1 / FL1	Upper / lower limit for the acceptable range within which OUT1 switches. Menu item only visible if window function is selected ([ou1] = [F..]).
ASP2	Analogue start point 2: measured value at which the analogue start value is provided. The analogue start value is set with parameter [ou2]. Menu item only visible if analogue output is selected ([ou2] = [I] or [InEG]).
AEP2	Analogue end point 2: measured value at which the analogue end value is provided. The analogue end value is set with parameter [ou2]. Menu item only visible if analogue output is selected ([ou2] = [I] or [InEG]).
SP2 / rP2	Set point 2 / reset point 2 at which OUT2 switches. Menu item only visible if hysteresis function is selected ([ou1] = [H..]).
FH2 / FL2	Upper / lower limit for the acceptable range within which OUT2 switches. Menu item only visible if window function is selected ([ou1] = [F..]).
EF ↵	Extended functions / opening of menu level 2

10.2.2 EF level (extended functions) [II]

rES	Restore the factory setting.
CFG ↵	Open the submenu CFG (configuration).
ENV ↵	Open the submenu ENV (environment parameter).
SIM ↵	Open the submenu SIM (simulation).

10.2.3 CFG level (configuration) [III]

ou1	Output configuration for OUT1: <ul style="list-style-type: none">• switching signal for level limit. Hysteresis or window function, normally closed or normally open.
ou2	Output configuration for OUT2: <ul style="list-style-type: none">• analogue signal for current level, 4...20 mA or 20...4 mA or• switching signal for level limit. Hysteresis or window function, normally closed or normally open.
dS1	Switch-on delay for OUT1
dr1	Switch-off delay for OUT1
dS2*)	Switch-on delay for OUT2
dr2*)	Switch-off delay for OUT2
uni	Selection of the unit of measurement on the sensor display (mm or inch)
P-n	Output polarity for the switching outputs (pnp or npn)
FOU1	Response of OUT1 in case of a fault
FOU2	Response of OUT2 in case of a fault
SEld	Selection of the type of indication
dAP	Damping of the measured signal (mean filter)
dFo	Delay time for the outputs to pass into the state defined with [FOUx]; only effective in case of a fault.
*) Menu item only visible with hysteresis or window function ([ou2] = [H..]) or [°F..]).	

10.2.4 ENV level (environment) [IV]

LEnG	Input of the probe length
MEdl	Medium selection



10.2.5 SIM level (simulation) [V]

S.LvL	Simulation of a level / an error state
S.Tim	Simulation duration 1...60 min
S.On	Simulation start/stop

11 Parameter setting

During parameter setting the device remains in the operating mode. It continues to monitor with the existing parameters until the parameter setting has been completed.

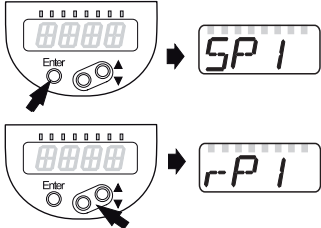
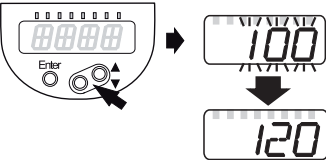
11.1 Parameter setting in general

<p>1 Select parameter</p> <ul style="list-style-type: none">▶ Press [Enter] to get to the menu.▶ Press [▲] or [▼] until the required parameter is displayed.	
<p>2 Set parameter value</p> <ul style="list-style-type: none">▶ Press [Enter] to edit the selected parameter.▶ Press [▲] or [▼] for min. 1 s.> After 1 s: setting value is changed: incrementally by pressing the button once or continuously by keeping the button pressed.	
<p>Numerical values are incremented continuously with [▲] or decremented with [▼].</p>	
<p>3 Acknowledge parameter value</p> <ul style="list-style-type: none">▶ Briefly press [Enter].> The parameter is displayed again. The new setting value is saved.	
<p>Set other parameters</p> <ul style="list-style-type: none">▶ Press [▲] or [▼] until the required parameter is displayed.	
<p>Finish parameter setting</p> <ul style="list-style-type: none">▶ Press [▲] or [▼] several times until the current measured value is displayed or wait for 30 s.> The unit returns to the process value display.	



[C.Loc] or [S.Loc] as operation indication see (→ 12.3).

- Change from menu level 1 to menu level 2:

<ul style="list-style-type: none"> ▶ Press [Enter] to get to the menu. ▶ Press [▲] or [▼] until [EF] is displayed. 	
<ul style="list-style-type: none"> ▶ Press [Enter]. > The first parameter of the submenu is displayed (here: [rES]). 	

- Timeout:

If no button is pressed for 30 s during parameter setting, the unit returns to the process value display with unchanged values.

- Lock / unlock

The unit can be locked electronically to prevent unintentional settings.

<ul style="list-style-type: none"> ▶ Make sure that the unit is in the normal operating mode. ▶ Press [▲] + [▼] simultaneously for 10 s. > [Loc] is displayed. 	
<p>During operation: [Loc] is briefly displayed if you try to change parameter values.</p>	
<p>For unlocking:</p> <ul style="list-style-type: none"> ▶ Press [▲] + [▼] simultaneously for 10 s. > [uLoc] is displayed. 	

11.2 Basic settings (set-up)

On delivery of the unit, you must first enter the basic settings. The complete user menu then opens.

11.2.1 Enter probe length

<ul style="list-style-type: none">▶ Select [LEnG].▶ Press [Enter].> [nonE] is displayed.▶ Press [▲] or [▼] for min. 1 s.> After 1 s the unit automatically displays the detected probe length (preset function).▶ Correct the probe length, if necessary, with [▲] or [▼], incrementally by pressing the button once or continuously by keeping the button pressed. Enter the probe length in inch.▶ Briefly press [Enter].	LEnG
<p>*) Automatic probe length detection is only possible with empty tank and sufficiently large launching plate.</p> <p>For manual determination of the probe length (→ 7.3.2).</p>	

11.2.2 Setting to the medium

<ul style="list-style-type: none">▶ Select [MEdI] and set: [HIGH] = For water and water-based media Operating mode is optimised for suppression of deposits on the probe.[MId] = For water-based media and media with a medium dielectric constant value, e.g. oil-in-water emulsions. Operating mode optimised for the detection of media with increased foam build-up.▶ Press [Enter].▶ Check proper function by an application test.	MEdI
--	-------------

Then the unit changes to the operating mode.

If required (e.g. when mounted in a connection piece) carry out a tank adjustment (parameter [tREF]) and set parameters to adapt to the application.

Setting ranges of all parameters (→ 13)

Factory settings of all parameters (→ 15)

11.2.3 Carry out tank adjustment

<p>Menu item only visible if [LEnG] \geq 260 mm.</p> <ul style="list-style-type: none">▶ Observe notes (\rightarrow 7.1.7).▶ Select [tREF].▶ Press [Enter]. <p>> [nonE] or the value saved from the last tank adjustment (distance value) is displayed.</p> <ul style="list-style-type: none">▶ Press [\blacktriangle] or [\blacktriangledown] for min. 1 s. <p>> The distance value is displayed (default value: 10 mm).</p> <ul style="list-style-type: none">▶ Correct the value, if necessary, with [\blacktriangle] oder [\blacktriangledown]. Incrementally by pressing the button once or continuously by keeping the button pressed.▶ Press [Enter]. <p>> [donE] is displayed.</p> <ul style="list-style-type: none">▶ Press [Enter] again. <p>> The unit reboots and then returns to the operating mode.</p>	tREF
--	-------------

11.3 Configure display (optional)

<ul style="list-style-type: none">▶ Select [uni] and set the unit of measurement: [mm], [inch]. Factory setting: inch.▶ Select [SELd] and set type of indication: [L] = The level is indicated in mm or inch. [%] = The level is indicated in percent of the measuring range / scaled measuring range. The level in percent depends on the parameters: [ASP2]: set value corresponds to 0 % [AEP2]: set value corresponds to 100 %[OFF] = The display is switched off in the operating mode. When one of the buttons is pressed, the current measured value is displayed for 30 s. The indicator LEDs remain active even if the display is deactivated.	uni SELd
--	---------------------

11.4 Set output signals

11.4.1 Set output function for OUT 1

<ul style="list-style-type: none">▶ Select [ou1] and set the switching function: [Hno] = hysteresis function / normally open [Hnc] = hysteresis function / normally closed [Fno] = window function / normally open [Fnc] = window function / normally closed <p>Note: If the switching output is used as an overflow prevention, the setting [ou1] = [Hnc] (normally closed function) is recommended. The principle of normally closed operation ensures that wire break or cable break is also detected.</p>	<i>ou 1</i>
---	-------------

11.4.2 Set switching limits (hysteresis function)

<ul style="list-style-type: none">▶ Make sure that the function [Hno] or [Hnc] is set for [oux]. Note: [I] is preset by the factory for [ou2], in this case SP/rP are not available.▶ Select [SPx] and set the value at which the output is set.	<i>SP 1 SP 2</i>
<ul style="list-style-type: none">▶ Select [rPx] and set the value at which the output is reset. [rPx] is always smaller than [SPx]. The unit only accepts values which are lower than the value for [SPx].	<i>rP 1 rP 2</i>

11.4.3 Set switching limits (window function)

<ul style="list-style-type: none">▶ Make sure that for [oux] the function [Fno] or [Fnc] is set.▶ Select [FHx] and set the upper limit of the acceptable range.	<i>FH 1 FH 2</i>
<ul style="list-style-type: none">▶ Select [FLx] and set the lower limit of the acceptable range. [FLx] is always lower than [FHx]. The unit only accepts values which are lower than the value for [FHx].	<i>FL 1 FL 2</i>

11.4.4 Set switch-on delay for switching outputs

<ul style="list-style-type: none">▶ Select [dSx] and set the value between 0.0 and 60 s. <p>The switch-on delay reacts according to VDMA*).</p>	<i>dS 1 dS 2</i>
---	----------------------

11.4.5 Set switch-off delay for switching outputs

<ul style="list-style-type: none">▶ Select [drx] and set the value between 0.0 and 60 s. <p>The switch-off delay reacts according to VDMA*).</p>	<i>dr 1 dr 2</i>
--	----------------------

* According to VDMA the switch-on delay always has an effect on [SPx], the switch-off delay

always on [rPx] irrespective of whether the normally open or normally closed function is used.

11.4.6 Set output function for OUT2

<p>▶ Select [ou2] and set the switching function:</p> <p>[I] = current output 4...20 mA [InEG] = current output 20...4 mA [Hno] = hysteresis function / normally open [Hnc] = hysteresis function / normally closed [Fno] = window function / normally open [Fnc] = window function / normally closed</p> <p>Note: If the output is used as an overflow prevention, the setting [ou2] = [Hnc] (NC function) is recommended. The principle of normally closed operation ensures that wire break or cable break is also detected.</p>	
---	---

11.4.7 Scale analogue signal

<p>▶ Select [ASP2] and set the analogue start point. ▶ Select [AEP2] and set the analogue end point.</p> <p>These parameters can only be set via an IO-Link device tool if the parameter [ou2] is set to [I] or [InEG].</p> <p>More information (→ 6.3.2)</p>	
---	---

11.4.8 Set output logic for switching outputs

<p>▶ Select [P-n] and set [PnP] or [nPn].</p>	
---	---

11.4.9 Set response of the outputs in case of a fault

<p>▶ Select [FOU1] / [FOU2] and set the value:</p> <p>[On] = Output switches ON in case of a fault. Analogue output switches to a value > 21 mA in case of a fault. [OFF] = Switching output switches OFF in case of a fault. Analogue output switches to a value < 3.6 mA in case of a fault.</p> <p>Examples of faults: defective hardware, signal quality too low. Overflow is not considered to be a fault!</p>	
---	--

11.4.10 Set damping for the measured signal

<p>▶ Select [dAP] and set damping in seconds; setting range: 0.0...60.0 s</p> <p>More information (→ 6.3.4).</p>	
--	---

11.4.11 Set delay time in case of a fault

- ▶ Select [dFo] and set a value between 0...10.0 s.

[dFo] only effective in case of a fault. Mind the dynamics of your application. In case of fast level changes it is recommended to adapt the value step by step.

More information (→ 6.3.6)

dFo

11.5 Reset all parameters to factory setting

- ▶ Select [rES].
 - ▶ Press [Enter] until [rES] is aligned right.
 - ▶ Press and hold [▲] or [▼] until [----] is displayed.
 - ▶ Press [Enter].
- > The unit reboots and the factory settings are restored.

Note: On delivery the unit is not operational. First, the first set-up must be made (→ 11.2).

rES

11.6 Change basic settings

Required after changes to the probe or application.

11.6.1 Re-enter probe length

- ▶ Select [LEnG] and set probe length L. Note the set unit [uni].
- ▶ Press [Enter].

Note: After changing the probe length, the values for the switching limits must also be reviewed / re-entered.

More information (→ 11.2.1)

LEnG

11.6.2 Set to another medium

- ▶ Select [MEdI] and set:

[HIGH] = for water and water-based media

[MId] = for water-based media and media with a mean dielectric constant value

- ▶ Press [Enter].

More information (→ 11.2.2)

MEdI

11.7 Simulation

11.7.1 Set simulation value

<ul style="list-style-type: none">▶ Select [S.LvL]▶ Set the process value to be simulated: [Numerical value] = level in mm / inch (depending on the basic setting) [FULL] = full state [SEnS] = weak measured signal [Err] = electronic fault found [EPTY] = empty state▶ Press [Enter].	<i>S.LvL</i>
--	--------------

11.7.2 Set simulation time

<ul style="list-style-type: none">▶ Select [S.Tim].▶ Set time span for simulation. Setting range: 1, 2, 3, 4, 5, 10, 15, 20, 30, 45, 60 min. Factory setting: 3 min.	<i>S.Tim</i>
---	--------------

11.7.3 Switch simulation on / off

<ul style="list-style-type: none">▶ Select [S.On] and set: [OFF] = simulation off [On] = simulation on▶ Press [Enter] to start the simulation.	<i>S.On</i>
---	-------------

 Simulation active until [Enter] is pressed again or the time set via [S.Tim] elapses. During the simulation [SIM] is displayed every 3 s. After the simulation the unit returns to the parameter [S.On] and internally the unit returns to the operating mode (and the process value transmission). After another 30 s the display changes to the process value display. The outputs react according to the simulated process values.

 If the simulation is started via IO-Link, it can also only be finished via IO-Link. During the attempt to finish the simulation via the buttons, C.Loc is displayed.

12 Operation

12.1 Single probe

This unit is intended for operation with a single probe.



A coaxial probe **cannot** be used with this unit.

The single probe is made up of one individual rod. Operation with a single probe is suited for the detection of aqueous media, in particular of heavily soiled aqueous media.



For a correct function the unit needs a sufficiently large metal launching surface / launching plate. It is necessary for transferring the microwave pulse to the tank with optimum transmission power.

For installation in closed metal tanks / metal bypass pipes, the tank lid / upper pipe section serves as a launching surface. For installation in open metal tanks, tanks made of plastic or metal tanks with plastic lids a sufficiently large fixing plate, a metal plate or similar must be used (→ 7.4.3) , (→ 7.4.4).

Furthermore, minimum distances to tank walls and structures in the tank must be adhered to (→ 7.1).

12.2 Function check

After power-on the device is in the operating mode. It carries out its measurement and evaluation functions and generates output signals according to the set parameters.

- ▶ Check whether the unit operates correctly.

12.3 Operation indication

---- continuous	Initialisation phase after power on
====	On delivery the unit is not operational. Basic settings required (→ 11.2).
[----]	Level below the active zone
Numerical value + LED 1	Current level in mm
Numerical value + LED 2	Current level in inches
Numerical value + LED 3	Current level in % of the scaled measuring range
LEDS 7 - 6	Switching status OUT2
LED 8	Switching status OUT1
[FULL] + numerical value alternately	Level has reached or exceeded the maximum measuring range (= overflow warning).
[Sim] + XXX alternately	Simulation active. XXX = state to be simulated (→ 11.7).
[S.On]	Simulation stopped (→ 11.7)
[Loc]	Unit locked via buttons; parameter setting is not possible. For unlocking press the two setting buttons for 10 s.
[uLoc]	Unit is unlocked / parameter setting is possible again.
[C.Loc]	The unit is temporarily locked. Parameter setting via IO-Link active.
[S.Loc]	Unit is permanently locked via software. This locking can only be removed via IO-Link.

12.4 Read the set parameters

- ▶ Briefly press [Enter] to open the menu.
- ▶ [▲] or [▼] scrolls through the parameters.
- ▶ Briefly press [Enter] to indicate the corresponding parameter value for about 30 s. Then the unit returns to the operating mode.

12.5 Change the display unit in the operating mode

(switching between length indication (mm / inch) and percentage)

- ▶ Briefly press [▲] or [▼] in the operating mode.
- > The selected unit is displayed for 30 s, the corresponding LED is on. With each push of the button the display type is changed.

12.6 Error indications

	Possible cause	Recommended measures
[Err]	Fault in the electronics.	Replace the unit.
[nPrb]	Probe detached from the unit; possibly incorrect setting of the probe length.	Check whether the probe is still attached to the unit. Check the parameter [LEnG].
[SEnS]	Measurement disturbed by heavy foam build-up or turbulence.	<ul style="list-style-type: none"> • Install the unit in a still pipe or bypass (→ 7.1). • Set / increment [dFo] (→ 11.4.11).
	Measurement disturbed by separation layers (e.g. oil layer on water).	<ul style="list-style-type: none"> • Remove oil by suction. • Stir the medium. • Check composition.
	Probe or process connection soiled.	Clean the probe and the process connection.
	Installation conditions not adhered to.	<ul style="list-style-type: none"> • Follow the installation instructions (→ 7). • Carry out or repeat a tank adjustment (→ 11.2.3).
	Probe length or sensitivity (setting to the medium) incorrect.	Correct the settings (→ 11.2), then carry out a tank adjustment, if necessary (→ 11.2.3).
[SCx] + LED 7 [SCx] + LED 8	Flashing: short circuit in switching output OUT1 or OUT2.	Remove the short circuit.
[SC] + LED 7 + LED 8	Flashing: short circuit in both switching outputs.	Remove the short circuit.
[PArA]	Faulty data set	Reset to factory settings (→ 11.5).

12.7 Output response in different operating states

	OUT1	OUT2*
Initialisation	OFF	OFF
Normal operation	according to the level and [ou1] setting	according to the level 4...20 mA
Fault	OFF for [FOU1] = [OFF] ON for [FOU1] = [On]	< 3.6 mA at [FOU2] = [OFF] > 21 mA at [FOU2] = [On]
* If the analogue function [ou2] = [I] has been selected. If the switching function has been selected: see column OUT1		

Additional information about the analogue output:

Full signal: With [ou2] = [I]: 20...20.5 mA
With [ou2] = [InEG]: 4...3.8 mA

Empty signal: With [ou2] = [I]: 4...3.8 mA
With [ou2] = [InEG]: 20...20.5 mA

13 Technical data



Technical data and scale drawing at www.ifm.com.

Setting ranges

[LEnG]	mm	inch
Setting range	150...2000	6.0...78.8
Step increment	5	0.2

The setting ranges for the switching limits ([SPx], [rPx], [FHx], [FLx]) depend on the probe length (L). In general the following applies:

	mm		inch	
	min	max	min	max
[SPx] / [FHx]	15	L - 30	0.6	L - 1.2
[rPx] / [FLx]	10	L - 35	0.4	L - 1.4
Step increment	1		0.05	

- [rPx] / [FLx] is always smaller than [SPx] / [FHx]. If [SPx] / [FHx] is shifted, [rPx] / [FLx] also shifts provided that the lower end of the setting range is not reached. Always set [SPx] / [FHx] first, then [rPx] / [FLx].

The setting ranges for analogue start point (ASP2) and analogue end point (AEP2) depend on the probe length (L). In general the following applies:

	mm		inch	
	min	max	min	max
[ASP2]	0	---	0	---
[AEP2]	---	L - 30	---	L - 1.2
Step increment	1		0.05	

- Minimum distance between [ASP2] and [AEP2] = 20 % of the active zone.

14 Maintenance / transport

- ▶ Keep the process connection free of deposits and foreign bodies.

Heavy soiling:

- ▶ Clean process connection and probe.

In case of longer operation separation layers can form in the medium (e.g. oil on water). This applies especially to still pipes or bypasses:

- ▶ Remove separation layers at regular intervals.

 When the medium is changed, it may also be necessary to adapt the unit settings (→ 11.2.2).

 Only if data storage is required in an IO-Link application:
The tank adjustment is not saved via IO-Link. After a replacement it must be carried out again (→ 11.2.3).

More information about data storage (→ 16.2)

- ▶ It is not possible to repair the unit.
- ▶ After use dispose of the unit in an environmentally friendly way in accordance with the applicable national regulations.
- ▶ In case of returns ensure that the unit is free from soiling, especially dangerous and toxic substances.
- ▶ For transport only use appropriate packaging to avoid damage of the unit.

15 Factory setting

	Factory setting	User setting
tREF	nonE	
SP1	50% VMR*	
rP1	0,2 inch below SP1	
ASP2	0% VMR*	
AEP2	100% VMR*	
dS1	0.0	
dr1	0.0	
ou1	Hno	
ou2	I	
uni	inch	
P-n	PnP	
FOU1	OFF	
FOU2	OFF	
SELd	L	
dAP	0.0	
dFo	3.0	
LEnG	nonE	
MEdl	nonE	
S.LVL	50 % LEnG	
S.Tim	3	
S.On	OFF	

* VMR = final value of the measuring range = LEnG value minus 1.2 (in inch).
 When the LEnG value is entered, the unit calculates the basic setting.

16 Notes on parameter setting via IO-Link



On delivery the unit is not operational.

During set-up, valid basic settings have to be sent to the device once even if the default settings correspond to the connected device. Make sure that the basic settings are entered correctly according to the attached probe and the medium to be detected.

16.1 Application example

- ▶ Enter probe length (parameter [LEnG]). Example: [LEnG] = [39.4] inch.
- ▶ Scale analogue output (parameters [ASP2] and [AEP2]; [AEP2] must at least be 20 % greater than [ASP2]!). Example: [AEP2] = [38] inch.
 - ▶ Alternatively: Set parameter [ou2] to [H..] or [F..].
- ▶ Select the medium (parameter [MEdl]). Example: [MEdl] = [Mld].
 - [HIGH] = For water and water-based media. Operating mode is optimised for suppression of deposits on the probe.
 - [Mld] = For water-based media and media with a mean dielectric constant value. Operating mode is optimised for media with increased foam build-up.
- ▶ Transfer the sensor data to the unit.
- ▶ Carry out a tank adjustment depending on the installation (parameter [tREF] or button "TEACH_TANK_REF").

If the adjustment distance (parameter [RefDist]) is to be adapted, this individual parameter has to be sent to the sensor first. Then the tank adjustment can be carried out. Select the adjustment distance according to, for example, the height of connection pieces or the position of structures in the tank. Within the adjustment distance, starting from the process connection, interfering reflections are compensated. Example: [RefDist] = [2] inch.

- ▶ Now all other settings can be carried out.



Only if data storage is required in an IO-Link application:

The tank adjustment is not saved via IO-Link. After a replacement it must be carried out again.



After a factory reset (button "Restore Factory Settings"), the device reboots and the factory settings are restored.

16.2 Unit locking / data storage (as from IO-Link V1.1)

The IO-Link master stores all parameters of the connected sensor (except tank adjustment, see above) if configured in the master (data storage). When a sensor is replaced by a sensor of the same type, the parameters of the old sensor are automatically written to the new sensor if configured in the master and if the new sensor has the original factory settings.

For safety reasons the parameter download can be refused by the sensor. Factory setting: [Open]

Data storage	- [Open] = unit allows parameter download
	- [Locked] = unit refuses parameter download

More information at www.ifm.com