



Operating instructions
Electronic level sensor
LR8009

GB

11421236 / 00 01 / 2022

Contents



1	Preliminary note	4
1.1	Symbols used	4
2	Safety instructions	5
3	Intended use	6
3.1	Accessories	6
3.2	Operation with single probe	7
3.3	Operation with coaxial probe	7
3.4	Application area	7
3.4.1	Restriction of the application area	8
4	Function	9
4.1	Measuring principle	9
4.2	Display functions	9
4.3	Switching function	9
4.4	Offset for indicating the real level in the tank	10
4.5	Probes for different tank heights	10
4.6	Safe state	10
4.7	Binary mode	11
5	Installation	12
5.1	Device with single probe	12
5.2	Device with coaxial probe	14
5.3	Installation of the probe	14
5.3.1	Installation of the rod	14
5.3.2	Installation of the coaxial pipe	15
5.4	Shortening of the probe	15
5.4.1	Shortening of the rod and determination of its length L	15
5.4.2	Shortening of the coaxial pipe	15
5.4.3	Determination of the probe length L when coaxial probes are used	16
5.5	Installation of the device with single probe	16
5.5.1	Installation in closed metal tanks (without flange plate)	16
5.5.2	Installation in closed metal tanks (with flange plate)	17
5.5.3	Installation in open tanks	18
5.5.4	Installation in plastic tanks	18
5.6	Installation of the device with coaxial probe in the tank	18
5.7	Alignment of the sensor housing	19
6	Electrical connection	20
7	Operating elements and display elements	21
8	Menu	22
8.1	Menu structure / switching mode (bin = OFF)	22
8.2	Menu structure / switching mode (bin = on)	23
8.3	Explanation of the menu	23
9	Parameter setting	25
9.1	IO-Link	25
9.2	Parameter setting in general	25
9.3	Basic settings (on delivery)	27
9.3.1	Entering the probe length	27
9.3.2	Setting to the medium	28
9.3.3	Entering the type of probe used	28
9.4	Setting ranges	28
9.5	Configuring the display	29
9.6	Offset setting	29
9.7	Setting the output signals	29
9.7.1	Setting the output function	29
9.7.2	Setting the switching limits (hysteresis function)	29
9.7.3	Setting the switching limits (window function)	29
9.7.4	Setting the switch-off delay	30
9.7.5	Setting the switching logic for the outputs	30

9.7.6	Setting response of the outputs in case of a fault	30
9.7.7	Setting the delay time after signal loss	30
9.8	Resetting all parameters to factory setting	30
9.9	Changing basic settings	30
9.9.1	Re-entering probe length	30
9.9.2	Setting to another medium	31
9.9.3	Changing the value of the type of probe used	31
10	Operation	32
10.1	Operating indicators	32
10.2	Reading the set parameters	32
10.3	Changing the display unit in the Run mode	32
10.4	Error indications	32
10.5	Output response in different operating states	33
11	Repair, maintenance and disposal	34
12	Applications	35
12.1	Storage tank / level monitoring	35
12.2	Storage tank	35
13	Factory setting	37

1 Preliminary note

You will find instructions, technical data, approvals and further information using the QR code on the unit / packaging or at www.ifm.com.

1.1 Symbols used

- ✓ Requirement
- ▶ Instructions
- ▷ Reaction, result
- [...] Designation of keys, buttons or indications
- Cross-reference
-  Important note
Non-compliance may result in malfunction or interference.
-  Information
Supplementary note

2 Safety instructions

- The unit described is a subcomponent for integration into a system.
 - The system architect is responsible for the safety of the system.
 - The system architect undertakes to perform a risk assessment and to create documentation in accordance with legal and normative requirements to be provided to the operator and user of the system. This documentation must contain all necessary information and safety instructions for the operator, the user and, if applicable, for any service personnel authorised by the architect of the system.
- Read this document before setting up the product and keep it during the entire service life.
- The product must be suitable for the corresponding applications and environmental conditions without any restrictions.
- Only use the product for its intended purpose (→ Intended use).
- If the operating instructions or the technical data are not adhered to, personal injury and/or damage to property may occur.
- The manufacturer assumes no liability or warranty for any consequences caused by tampering with the product or incorrect use by the operator.
- Installation, electrical connection, set-up, operation and maintenance of the product must be carried out by qualified personnel authorised by the machine operator.
- Protect units and cables against damage.
- Only use the product for permissible media (→ Technical data).
- The unit complies with the standard EN 61000-6-4 and is a class A product. The unit may cause radio interference in domestic areas. If interference occurs, the user must take appropriate actions.

3 Intended use

The device continuously monitors the level in tanks and generates output signals according to the parameter settings.

4 switching outputs are available.

The outputs can be set separately.



In addition, the following is necessary for installation and operation:

- One rod (for operation of the device with single probe) → Accessories.
- Plus one coaxial pipe (for operation of the device with coaxial probe) → Accessories.
- Mounting material (if necessary, a launching plate) → Accessories.

3.1 Accessories



Only use accessories from ifm electronic gmbh. The function is not ensured when using components from other manufacturers.

The following components are available as accessories:

Rods	
Length (cm)	Order number
15	E43225
24	E43203
30	E43226
45	E43204
50	E43227
70	E43205
100	E43207
120	E43208
140	E43209
160	E43210

Coaxial pipes with G $\frac{3}{4}$ process connection	
Length (cm)	Order number
24	E43211
30	E43228
45	E43212
50	E43229
70	E43213
100	E43214
120	E43215
140	E43216
160	E43217

Coaxial pipes with 3/4" NPT process connection	
Length (cm)	Order number
45	E43218
70	E43219
100	E43220
120	E43223
140	E43224
160	E43221

Flange plates	
Size / process connection	Order number
73 - 90 / G3/4	E43201
65 - 80 / G3/4	E43202

3.2 Operation with single probe

The single probe is made up of one individual rod and is suited for the detection of aqueous media, in particular of heavily soiled aqueous media.



For the correct function with single probe, the device needs a large enough metal launching plate. It is necessary for transferring the microwave pulse to the tank with optimum transmission power.

The flange plates that are available as accessories are not sufficient as launching plates. Only use accessories indicated as "launching plate".

For installation in closed metal tanks, the tank lid serves as a launching plate. For installation in open metal tanks, tanks made of plastic or metal tanks with plastic lids a sufficiently large fixing plate, a metal plate or similar must be used.

For operation with single probe, minimum distances to tank walls, objects in the tank, bottom of the tank and further level sensors must be adhered to.

3.3 Operation with coaxial probe

The coaxial probe is made up of an inner rod and an outer probe pipe (coaxial pipe). The rod is centred in the coaxial pipe by one or several spacers.

In case of operation with a coaxial probe media with a low dielectric constant (e.g. oil and oil-based media) are detected in addition to aqueous media.



No launching plate is required for operation with coaxial probe. Furthermore, no minimum distances to tank walls and objects in the tank are required.

3.4 Application area

- Water, water-based media
- Oils, oil-based media (only for operation with coaxial probe)

Application examples:

- Detection of coolant emulsion in a machine tool.
- Detection of cleaning liquid in a parts cleaning system.
- Monitoring of hydraulic oil in a hydraulic power unit (only for operation with coaxial probe).

3.4.1 Restriction of the application area



Incorrect measurements or signal loss may be caused by the following media:

Highly absorbing surfaces (e.g. foam).

Intensely bubbling surfaces.

Media which are very inhomogeneous, separate from each other thus forming separation layers (e.g. oil layer on water).

- ▶ Check the function by performing an application test.
- ▶ Installation in a steady area.
- ▷ In case of signal loss, the device displays [E.033] and switches the outputs to a defined state.

The device is not suitable for bulk materials (e.g. plastic granulates).

The device is not suitable for applications where the probe is subjected to permanent and high mechanical stress (e.g. heavy movement of viscous media or fast flowing media).

When installed in plastic tanks, deterioration caused by electromagnetic interference may occur (noise immunity to EN61000-6-2).

In case of operation with coaxial probe: not suitable for soiled or viscous media and media prone to formation of deposit. Maximum viscosity: 500 mPa · s.

- If the device is to be used in acids or alkalis, in hygienic areas or in electroplating applications:
 - ▶ Check the compatibility of the product materials with the media to be monitored.
- In case of operation with single probe:
 - ▶ Use preferably in metal tanks.
 - ▶ In case of operation in small tanks (rod lengths shorter than 200 mm and less than 300 mm distance to the tank wall), interference from the tank (resonances) may occur in rare cases.

4 Function

This unit has an IO-Link communication interface which enables direct access to process and diagnostic data. In addition it is possible to set the parameters of the unit while it is in operation. Operation of the unit via the IO-Link interface requires an IO-Link master.

With a PC, suitable IO-Link software and an IO-Link adapter cable, communication is possible while the system is not in operation.

The IODDs necessary for the configuration of the unit, detailed information about process data structure, diagnostic information, parameter addresses and the necessary information about the required IO-Link hardware and software can be found at www.ifm.com.

4.1 Measuring principle

The device operates on the principle of guided wave radar. It measures the level using electromagnetic pulses in the nanosecond range.

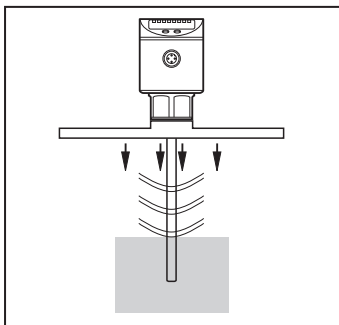

Fig. 1: Transmitting

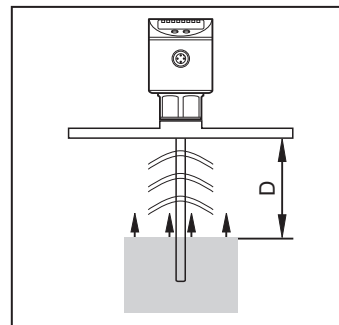

Fig. 2: Receiving

The pulses are transmitted by the sensor head and guided along the rod (Fig. Transmitting). When they hit the medium to be detected they are reflected and guided back to the sensor (Fig. Receiving). The time between transmitting and receiving the pulse directly relates to the travelled distance (D) and the current level. The reference for distance measurement is the lower edge of the process connection.



The figures show operation with single probe. In case of operation with a coaxial probe, the guided wave runs only along the inside of the coaxial pipe.

4.2 Display functions

The device displays the current level, either in cm or in percent of the final value of the measuring range. Factory setting: cm.

The display unit is defined by programming. In the Run mode, it can be temporarily switched between length indication (cm) and percentage:

- ▶ Briefly press [Set].
- ▷ The selected unit is displayed for 30 s, the corresponding LED is lit. With each push of the button the display type is changed.

The set unit of measurement and the switching status of the outputs are indicated by LEDs.

4.3 Switching function

The device signals via four switching outputs (OUT1... OUT4) that a set limit value has been reached or that the level is below the limit value. For each output the following switching functions can be selected:

- Hysteresis function / normally open (Fig. Hysteresis function): [OUx] = [Hno].

- Hysteresis function / normally closed (Fig. Window function): $[OUx] = [Hnc]$.



First the switch point (SPx) is set, then the switch-off point (rPx) with the requested difference.

- Window function / normally open (Fig. Hysteresis function): $[OUx] = [Fno]$.
- Window function / normally closed (Fig. Window function): $[OUx] = [Fnc]$.



The width of the window can be set by means of the difference between FHx and FLx. FHx = upper value, FLx = lower value.

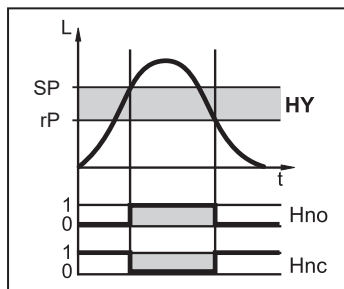

Fig. 3: Hysteresis function

L: level
HY: hysteresis
FE: window

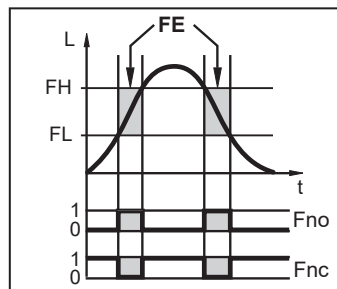

Fig. 4: Window function

L: level
HY: hysteresis
FE: window

For each switching output, a switch-off delay of max. 60 s can be set (e.g. for especially long pump cycles).

4.4 Offset for indicating the real level in the tank

The zone between tank bottom and lower edge of the probe can be entered as offset value [OFS]. So display and switch points refer to the actual level.

4.5 Probes for different tank heights

The device can be installed in tanks of different sizes. Probes in different lengths are available. To adapt to the tank height, each probe can be shortened. The minimum probe length is 10 cm, the maximum probe length is 160 cm.

Probe and housing can be rotated without restriction. This enables easy installation and orientation of the head of the device after installation.

4.6 Safe state

In case of a fault a safe state can be defined for each output.

If a fault is detected or if the signal quality is below a minimum value, the outputs pass into the "safe state". For this case the response of the outputs can be set via the parameters [FOU1]...[FOU4].

Temporary loss of signal caused e.g. by turbulence or foam formation can be suppressed by a delay time [dFo].

During the delay time the last measured value is frozen. If the measured signal is received again in sufficient strength within the delay time, the device continues to work in normal operation. If, however, it is not received again in sufficient strength within the delay time, the outputs pass into the safe state.



In case of heavy foam build-up and turbulence:

- Note the examples of how to create a steady area.

4.7 Binary mode

In the binary mode the outputs OUT1...OUT4 indicate the level as a 8-4-2-1 binary code. Thus a quasi-analogue evaluation with a resolution of 15 steps (about 6.6 % of the active zone (A)) is available.

Below the rod and in the zone I2 the word 0000 is output (step 0). In the active zone (A) the steps 1...15 are passed through and the outputs switch to the shown states. If the active zone is exceeded (zone I1), the value of step 15 (word 1111) continues to be output.

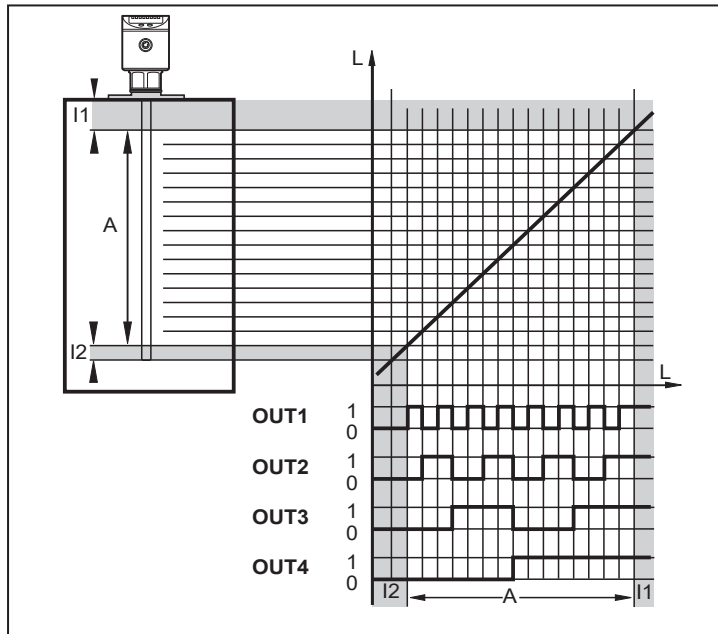

For the zones A, I1 and I2: → Technical data sheet.

5 Installation

Vertical installation from the top is preferred.

5.1 Device with single probe

For a safe function, the device requires a launching plate.

The following minimum distances between the rod and tank walls, objects in the tank (B), tank bottom and other level sensors must be adhered to:

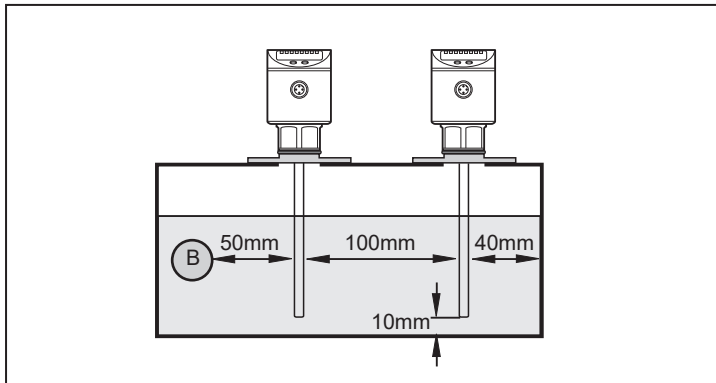

For tank walls which are not straight, steps, supports or other structures in the tank a distance of 50 mm to the tank wall must be adhered to.

When operating the device in small tanks (rod lengths shorter than 200 mm and less than 300 mm distance to the tank wall), mount the device off-centre (eccentrically) to prevent possible interference from tank resonances.

For probe lengths > 70 cm the rod can be considerably deflected by movement of the medium. To avoid contacting the tank wall or other structures in the tank in such cases, the minimum distances should be increased. Reference values:

Probe length	Distance to the tank wall or structures in the tank
70...100 cm	100 mm
100...160 cm	180 mm

If the medium is highly polluted, there is the risk that a bridge forms between the rod and the tank wall or structures in the tank. To avoid incorrect measurements: adhere to increased minimum distances depending on type and intensity of the soiling.

For installation in pipes:

- The inside pipe diameter (d) must be at least 100 mm (Fig. Installation on a pipe).
- If possible, mount the device off-centre (eccentrically).
- Only install the device in metal pipes.

For installation in a boss:

- The diameter of the boss (d) must be at least 60 mm (Fig. Installation in a boss).
- The height of the boss (h) must not exceed 40 mm (Fig. Installation in a boss).

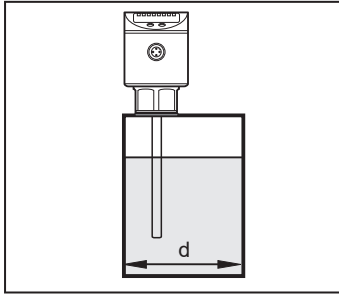

Fig. 5: Installation on a pipe

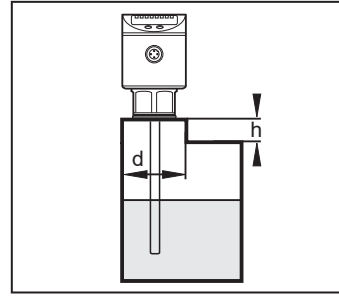
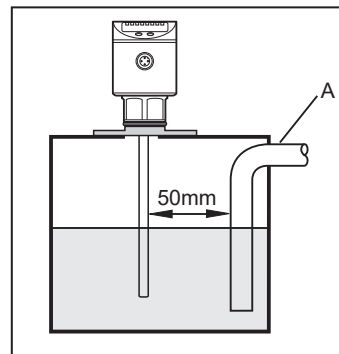
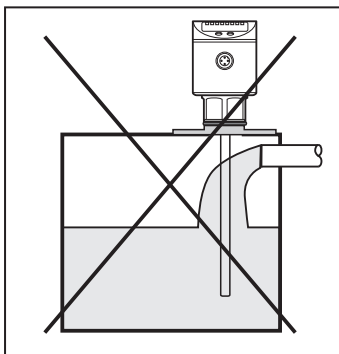

Fig. 6: Installation in a boss



Although the device can be installed in a boss: installation in a flat tank lid is recommended, as a boss will impede the distribution of the microwaves.

Do not install the device in the immediate vicinity of a fill opening. If possible, install a fill pipe (A) in the tank. Minimum distance between the fill pipe and the rod = 50 mm; higher for probe lengths > 70 cm and in case of heavy soiling.



To avoid incorrect measurements in case of heavy foam formation and turbulence:

- ▶ If possible, install the sensor in a steady area.

Examples of how to create a steady area:

- ▶ Use of a coaxial probe (only for clean, low-viscosity media)
- ▶ Installation in bypass or still pipe
- ▶ Separation of the installation location by metal sheets / perforated sheets (without figure)



Min. diameter of the bypass and still pipe: $d = 100 \text{ mm}$.

The upper access to the steady area (Fig. A / B) must be above the max. level. The lower access (Fig. C / D) or the area with perforated sheet etc. must be below the min. level. This ensures that neither foam nor turbulence impact the sensor zone. Besides, the use of perforated sheets or the like can help to avoid soiling (e.g. by metal swarf, particles).

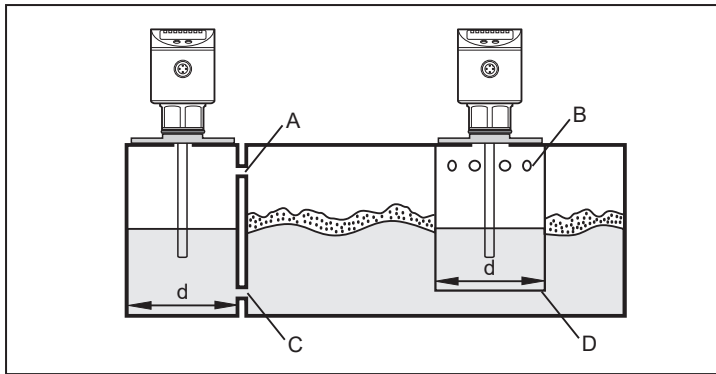

- d: Min. diameter bypass and still pipe
 A: Upper access to the steady area
 B: Upper access to the steady area
 C: Lower access to the steady area
 D: Lower access to the steady area

5.2 Device with coaxial probe

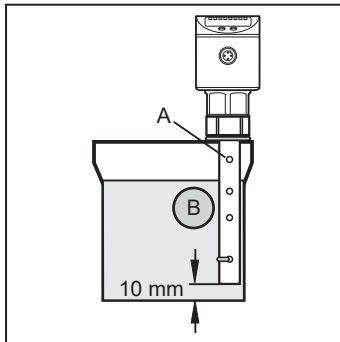

- No minimum distances to the tank wall and structures in the tank (B) are required.
- ▶ Minimum distance to the bottom of the tank: 10 mm.
- ▶ The vent hole (A) must not be covered by mounting elements or similar.
- ▶ Do not install the device in the immediate vicinity of a fill opening. No water jets must enter into the holes of the coaxial pipe.

Note in case of foam build-up:

- ▶ The vent of the coaxial pipe must be above the maximum level.
- ▶ The lower edge of the coaxial pipe must be below the minimum level.

5.3 Installation of the probe

Rod and coaxial pipe are not included in the scope of delivery. They must be ordered separately: → Accessories.

5.3.1 Installation of the rod

Fixing of the rod:

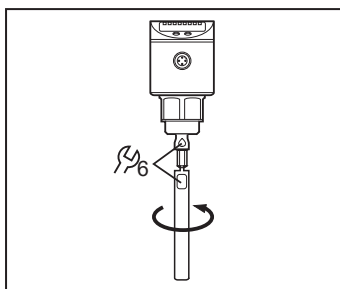

- ▶ Screw the rod to the device and tighten it.
Tightening torque: 4 Nm

For ease of installation and removal the rod connection can be rotated without restriction. Even if rotated several times there is no risk of damage to the device.

In case of high mechanical stress (strong vibration, moving viscous media) it may be necessary to secure the screw connection, e.g. by a screw retaining compound.



Substances such as screw retaining compounds may migrate into the medium.

- ▶ Make sure that they are harmless.

When using mechanical means of securing (e.g. tooth lock washer), protruding edges must be avoided. They may cause interference reflection.

5.3.2 Installation of the coaxial pipe

This chapter is only relevant if the device is to be operated with a coaxial probe.



The coaxial pipe and the rod must be of the same end length. The coaxial pipe can be shortened.

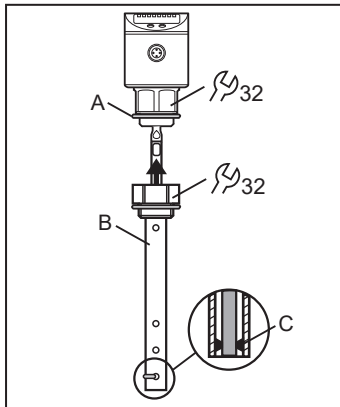

- ▶ Screw the rod to the device and tighten it. Tightening torque: 4 Nm.
- ▶ Slide the sensor seal (A) onto the thread.
- ▶ Slide the coaxial pipe (B) onto the rod. Carefully centre it and carefully move the rod through the centring piece (C) – for lengths > 140 cm through both centring pieces – of the coaxial pipe. Do not damage the centring pieces.
- ▶ Screw onto the sensor thread and tighten.

5.4 Shortening of the probe

5.4.1 Shortening of the rod and determination of its length L

The rod can be shortened to adapt to different tank heights.



Ensure that the probe length is never below the minimum permissible length (L_{\min}) of 10 cm! The device does not support probe lengths below 10 cm. If shorter probes are used, measurement errors can occur.

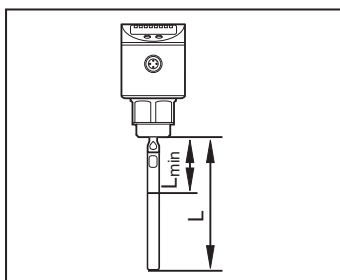

- ▶ Screw the rod to the device.
- ▶ Mark the desired length (L) on the rod. The reference point is the lower edge of the process connection.
- ▶ Remove the rod from the device.
- ▶ Shorten the rod at the mark.
- ▶ Remove all burrs and sharp edges.
- ▶ Screw the rod to the device again and tighten it. Tightening torque: 4 Nm.
- ▶ Precisely measure the probe length L and note the value. It must be entered during parameter setting of the device.

5.4.2 Shortening of the coaxial pipe

The coaxial pipe and the rod must be of the same end length:

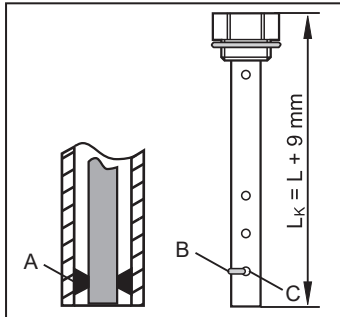
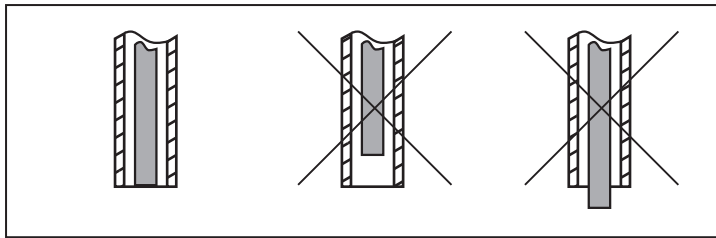

- ▶ Remove the fastening bracket and the centring piece (A, B).
- ▶ Shorten the coaxial pipe to the requested length: $L_K = L + 9 \text{ mm}$.
- ▶ After shortening, at least one hole (C) for insertion of the fixing bracket has to be left.
- ▶ Remove all burrs and sharp edges.
- ▶ Insert the centring piece (A) at the lower end of the pipe and attach it using the fixing bracket (B) at the lower hole (C).

L_K : length of the coaxial pipe

L: length of the rod from the lower edge of the process connection

5.4.3 Determination of the probe length L when coaxial probes are used

Only relevant if the rod length L is unknown:

- ▶ Measure the exact total length L_K of the coaxial pipe.
- ▶ Deduct 9 mm from the total length of the coaxial pipe: $L_K - 9 \text{ mm} = L$
- ▶ Note down L. It must be entered during parameter setting of the device.

5.5 Installation of the device with single probe



For the correct function when used with single probe, the device needs a large enough metal launching plate. It is necessary for transferring the microwave pulse to the tank with optimum transmission power.

For installation in closed metal tanks, the tank lid serves as a launching plate. Two ways of installation are possible:

- Screw in a G $\frac{3}{4}$ process connection in the tank lid.
- Installation in the tank lid using a flange plate, e.g. for tanks with thin walls.

Furthermore, installation in open tanks and plastic tanks is possible.

5.5.1 Installation in closed metal tanks (without flange plate)

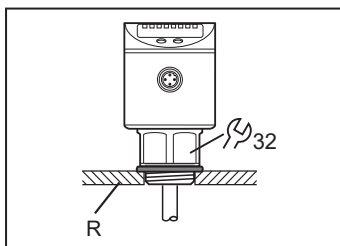

- ▶ Ensure that the lower edge of the process connection is flush with the installation environment.

R: tank lid /
launching plate

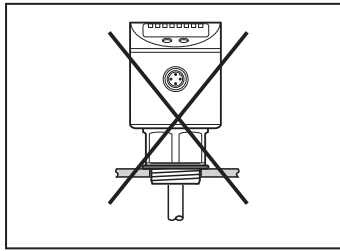

► Avoid non-flush installation.

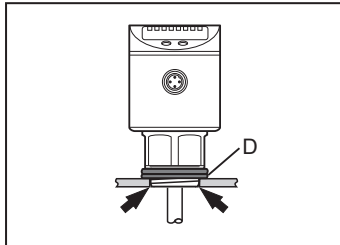

► If necessary, use seals or washers (D) to reach the required height.
 ► For tanks with thick walls arrange for sufficiently deep recesses to ensure flush installation.

5.5.2 Installation in closed metal tanks (with flange plate)



Flange plates are not supplied. They must be ordered separately: → Accessories.

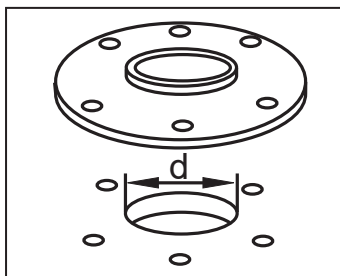

► Arrange for a hole in the tank lid. It must have a minimum diameter (d) to enable sufficient transfer of the measured signal to the probe. The diameter depends on the wall thickness of the tank lid:

Wall thickness [mm]	1...5	5...8	8...11
Bore hole diameter d [mm]	35	45	55

► Install the flange plate with the flat surface showing to the tank and fix it with appropriate screws.

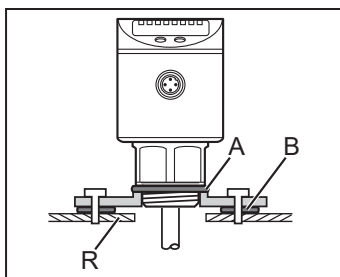

A: sensor seal
 B: tank seal
 R: tank lid / launching plate



A seal (B) can be inserted between flange plate and tank. Some flange plates are supplied with a seal.

- Ensure cleanness and evenness of the sealing areas, especially if the tank is under pressure. Tighten the fixing screws sufficiently.
- Screw the device into the flange plate using the process connection and tighten firmly.
- Make sure that the supplied sensor seal (A) is correctly positioned.

5.5.3 Installation in open tanks

- ▶ For installation in open tanks, use a metal fixture to install the device. It serves as a launching plate (R); minimum size: 150 x 150 mm for a square fixture, 150 mm diameter for a circular fixture: (→ Accessories).
- ▶ Mount the device in the middle of the fixture. The distance D2 must not be below 40 mm, higher for probe lengths > 70 cm and in case of heavy soiling.

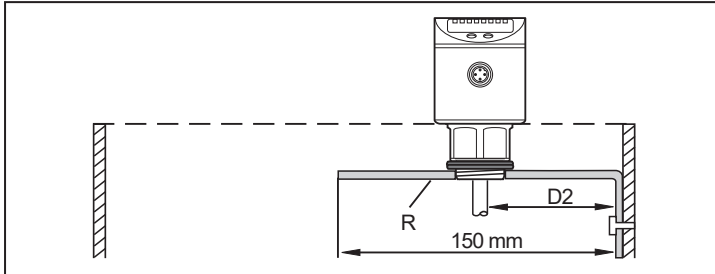

R: fixture / launching plate
D2: distance to the fixture

- ▶ Ensure that the lower edge of the process connection is flush with the installation environment.
- ▶ Avoid non-flush installation.
- ▶ If necessary, use seals or washers to reach the required height.

5.5.4 Installation in plastic tanks

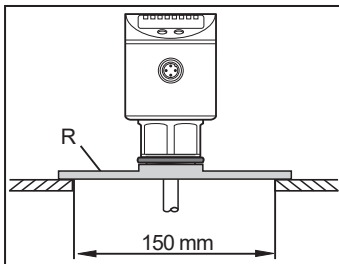

R: flange plate

- !** To enable sufficient transfer of the measured signal, note in case of installation in plastic tanks or metal tanks with plastic lid:

 - ▶ There must be a hole of at least 150 mm in diameter in the plastic lid.
 - ▶ For installation of the device, a metal flange plate (= launching plate R) must be used which sufficiently covers the drill hole: (→ Accessories).
 - ▶ Ensure the minimum distance (= 80 mm) between rod and tank wall, higher for probe lengths > 70 cm and in case of heavy soiling.
- !** When installed in plastic tanks, there may be deterioration caused by electromagnetic interference. Corrective measures:

 - ▶ Apply a metal foil to the outside of the tank.
 - ▶ Apply a shielding screen between the level sensor and other electronic devices.
 - ▶ Operation with coaxial probe efficiently protects the device from electromagnetic interference. Please note the restrictions regarding the application area.

5.6 Installation of the device with coaxial probe in the tank

- ▶ Seal the process connection:
 - For pipes with G $\frac{3}{4}$ process connection: slide the supplied seal onto the thread of the coaxial pipe.

- For pipes with $\frac{3}{4}$ " NPT process connection:
apply a suitable sealing material (e.g. Teflon tape).
- ▶ Screw the device with the coaxial pipe into the tank and tighten it.

5.7 Alignment of the sensor housing



After installation, the sensor housing can be aligned. It can be rotated without restriction. Even if rotated several times there is no risk of damage to the device.

6 Electrical connection



The device must be connected by a qualified electrician.

The national and international regulations for the installation of electrical equipment must be adhered to.

Supply voltage SELV, PELV according to the technical data sheet.

- ▶ Disconnect power.
- ▶ Connect the device as follows:



When the device is supplied with operating voltage for the first time, the probe length, the medium to be detected and the type of probe used must be entered. Only then is the device ready for operation.

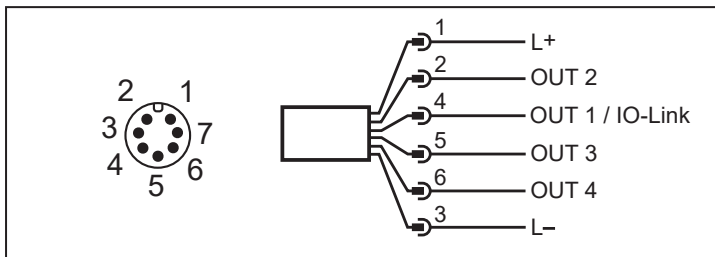

Pin	Core colour	
1:	BN	brown
2:	WH	white
3:	BU	blue
4:	BK	black
5:	GY	grey
6:	PK	pink
7: not used	VT	violet
OUT1:		
<ul style="list-style-type: none"> • Switching output • IO-Link 		
OUT2:		
<ul style="list-style-type: none"> • Switching output 		
OUT3:		
<ul style="list-style-type: none"> • Switching output 		
OUT4:		
<ul style="list-style-type: none"> • Switching output 		
Colours to DIN EN 60947-5-2		

Connector 8-pole on connector 4-pole available as accessories: www.ifm.com

7 Operating elements and display elements

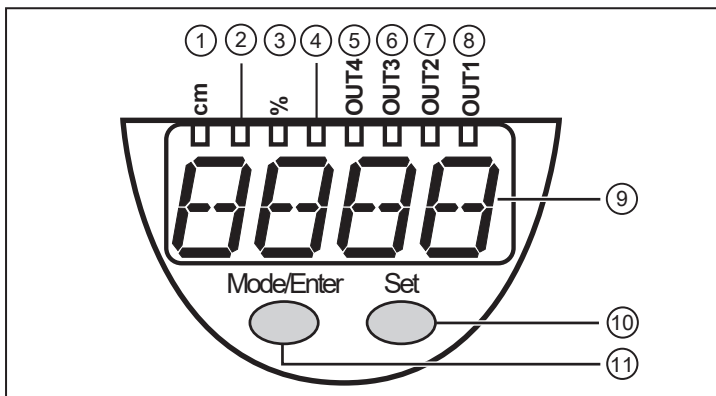

1 to 8: Indicator LEDs

LED 1	green = indication of the level in cm.
LED 2	not used.
LED 3	green = indication of the level in % of the final value of the measuring range.
LED 4	not used.
LED 5	yellow = output 4 is switched.
LED 6	yellow = output 3 is switched.
LED 7	yellow = output 2 is switched.
LED 8	yellow = output 1 is switched.

9: Alphanumeric display, 4 digits

- Indication of the current level.
- Operation and fault indication.
- Indication of the parameters and parameter values.

10: Set button

- Setting of the parameter values (scrolling by holding pressed, incrementally by pressing once).
- Change between cm indication and percent indication in the normal operating mode (Run mode).

11: Mode/Enter button

- Selection of the parameters and acknowledgement of the parameter values.

8 Menu

8.1 Menu structure / switching mode (bin = OFF)

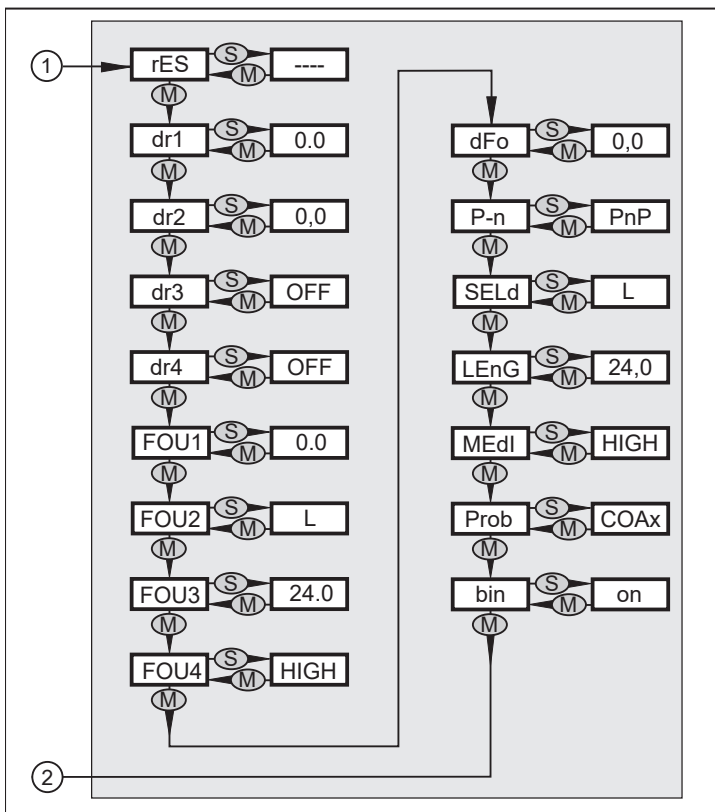
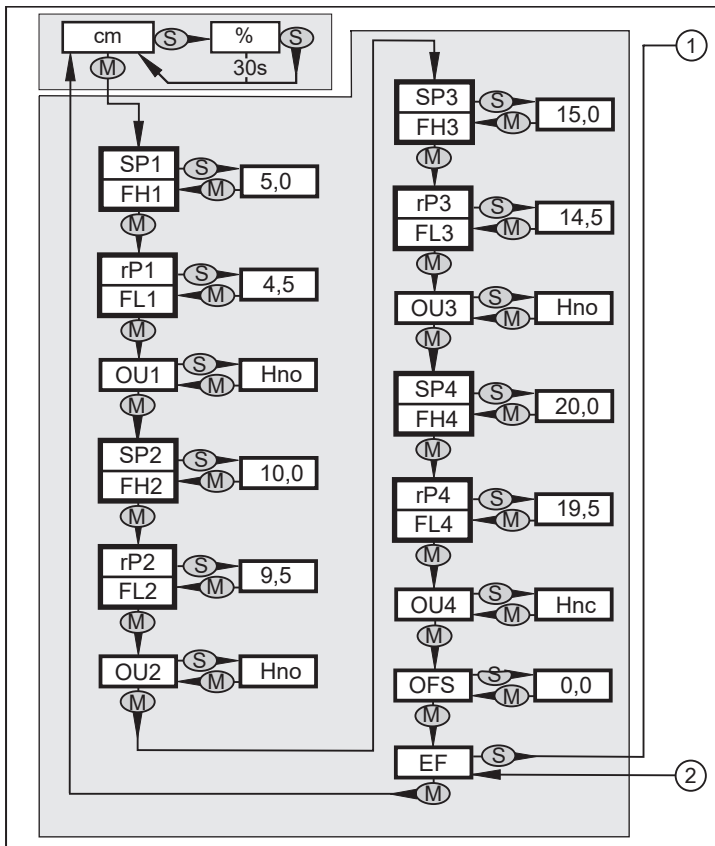

8.2 Menu structure / switching mode (bin = on)

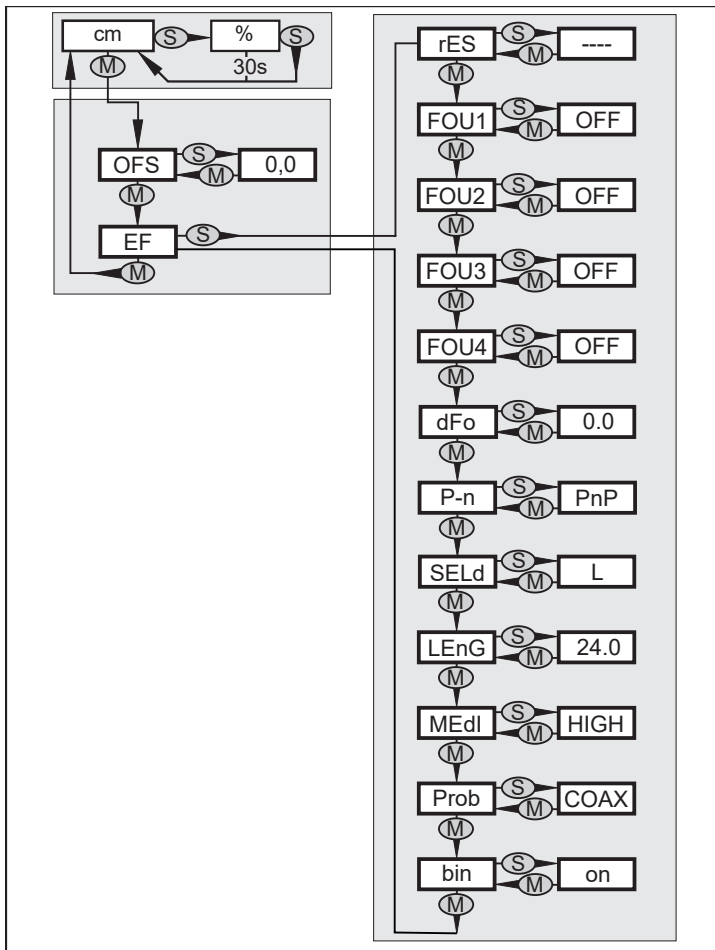

8.3 Explanation of the menu

SP1/rP1	Upper / lower limit value for the level at which OUT1 switches.
FH1/FL1	Upper / lower limit for the acceptable range (monitored by OUT1).
SP2/rP2	Upper / lower limit value for the level at which OUT2 switches.
FH2/FL2	Upper / lower limit for the acceptable range (monitored by OUT2).
SP3/rP3	Upper / lower limit value for the level at which OUT3 switches.
FH3/FL3	Upper / lower limit for the acceptable range (monitored by OUT3).
SP4/rP4	Upper / lower limit value for the level at which OUT4 switches.
FH4/FL4	Upper / lower limit for the acceptable range (monitored by OUT4).
OUx	Output function for OUTx: Switching signal for level limit values: hysteresis function [H..] or window function [F..], either normally open [.no] or normally closed [.nc].
OFS	Offset value for level measurement.
EF	Extended functions / opening of menu level 2.
rES	Restore factory setting.
dr1	Switch-off delay for OUT1: The menu item is only active if OU1 = Hno or Hnc.
dr2	Switch-off delay for OUT2: The menu item is only active if OU2 = Hno or Hnc.
dr3	Switch-off delay for OUT3: The menu item is only active if OU3 = Hno or Hnc.

dr4	Switch-off delay for OUT4: The menu item is only active if OU4 = Hno or Hnc.
FOUx	Response of OUTx in case of a fault.
dFo	Delay time for switching response OUTx.
P-n	Output polarity for the switching outputs (PnP or nPn).
SELd	Type of indication.
LEnG	Probe length.
MEdI	Medium to be detected.
Prob	Type of probe used (single probe or coaxial probe). The menu item is only active if MEdI = HIGH.
bin	Changing between switching mode and binary mode.

9 Parameter setting

The parameters can be set via the buttons on the device or the IO-Link interface.

During parameter setting the device remains in the operating mode internally. It continues its monitoring functions with the existing parameters until the parameter setting has been completed.

9.1 IO-Link

IO-Link is an internationally standardised IO technology (IEC 61131-9) for communicating with sensors and actuators.



Further information about IO-Link at: www.io-link.com

IO-Link offers the following advantages:

- Noise-immune transmission of several process values.
- Parameter setting during operation as well as point-to-point at the desk.
- Device diagnostics (events)
- Data storage: Automatic new parameter setting in case of replacement.
- Detection of connected units.
- Freely definable parameters to identify the units in the plant.



Information and documentation on the IO-Link interface at: www.io-link.ifm

9.2 Parameter setting in general

3 steps must be taken for each parameter setting:

1: Select parameter

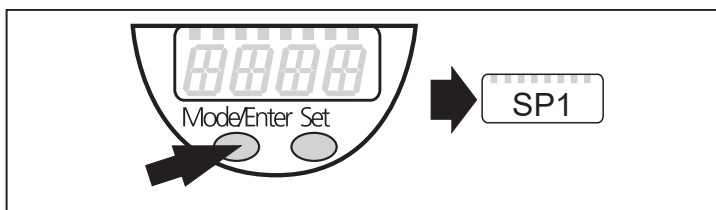

- ▶ Press [Mode/Enter] until the requested parameter is displayed.

2: Set parameter value

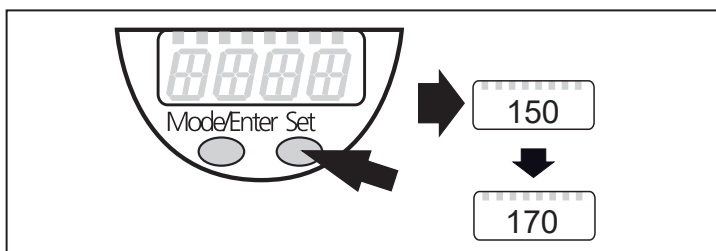

- ▶ Press [Set] and keep it pressed.
- ▷ Current setting value of the parameter flashes for 5 s.
- ▷ After 5 s: the setting value is changed.
Incrementally by pressing the button once or continuously by keeping the button pressed.

- ▷ The numerical values are incremented continuously.

For reducing the value:

- ▶ Let the display move to the maximum setting value. Then the cycle starts again at the minimum setting value.

3: Acknowledge parameter value

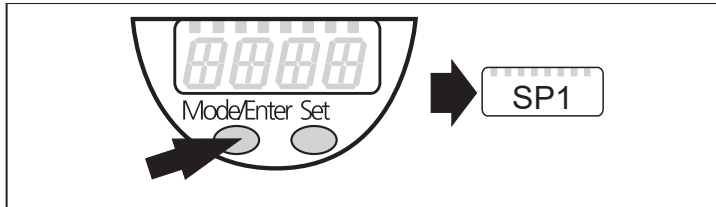

- ▶ Briefly press [Mode/Enter].
- ▷ The parameter is displayed again. The new setting value is saved.

Setting other parameters:

- ▶ Start again with step 1.

Finishing the parameter setting:

- ▶ Press [Mode/Enter] several times until the current measured value is displayed, or wait for 30 s.
- ▷ The sensor returns to the process value display.



If [C.Loc] is displayed when an attempt is made to modify a parameter value, a parameter setting process is active via the IO-Link communication (temporary locking).



If [S.Loc] is displayed, the sensor is permanently locked via software. This locking can only be removed with a parameter setting software.

Changing from menu level 1 to menu level 2

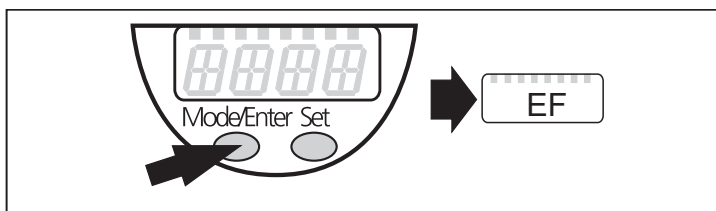

- ▶ Press [Mode/Enter] until [EF] is displayed.

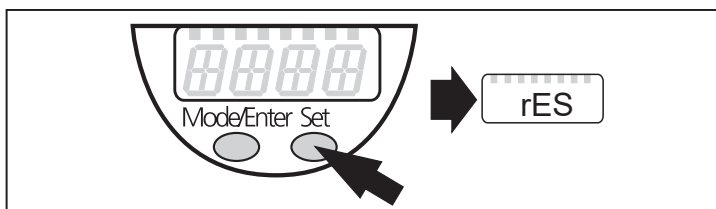

- ▶ Briefly press [Set].
- ▷ The first parameter of the submenu is displayed (here: [rES]).

Locking / unlocking

The device can be locked electronically to prevent unintentional settings.

Locking:

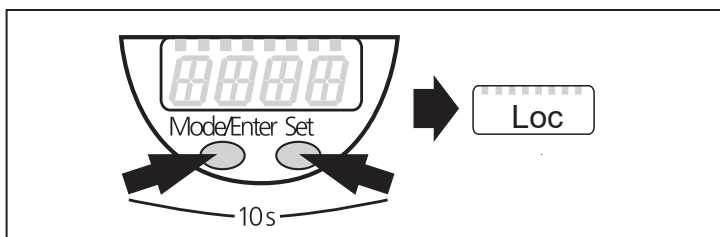

- ▶ Make sure that the device is in normal operating mode.
 - ▶ Press [Mode/Enter] + [Set] simultaneously for 10 s.
 - ▷ [Loc] is displayed.
- [Loc] is briefly displayed if you try to change parameter values.

Unlocking:

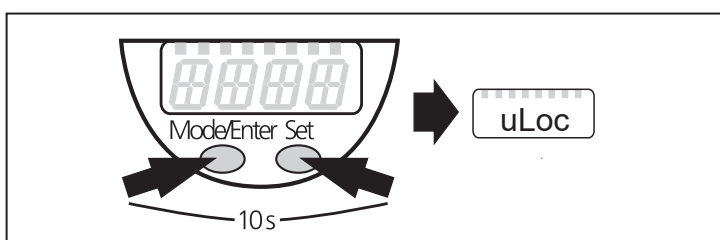

- ▶ Press [Mode/Enter] + [Set] simultaneously for 10 s.
- ▷ [uLoc] is displayed.

Timeout:

If no button is pressed for 30 s during parameter setting, the device returns to the operating mode with unchanged values.

9.3 Basic settings (on delivery)

On delivery of the device, you must first enter the basic settings. The complete parameter setting menu cannot be accessed before this.



Malfunctions may occur if wrong basic settings are entered.

9.3.1 Entering the probe length

<ul style="list-style-type: none"> ▶ Apply operating voltage. ▷ The initial display $\Xi \Xi \Xi \Xi$ appears. ▶ Select [LEnG], press [Set] for 5 s. ▷ [nonE] is displayed. ▶ Enter the probe length in cm. Observe the notes on the determination of the probe length (single probes or coaxial probes). ▶ Briefly press [Mode/Enter]. 	[LEnG]
--	--------

9.3.2 Setting to the medium

<p>▶ Select [MEdI], press [Set] for 5 s.</p> <p>▷ [nonE] is displayed.</p> <p>▶ Set the requested value:</p> <ul style="list-style-type: none"> • [HIGH] for water and water-based media. • [LOW] for oils and oil-based media. <p>Note: in case of doubt, carry out an application test to ensure the setting which is best for your medium.</p>	[MEdI]
---	--------

9.3.3 Entering the type of probe used

<p>▶ Select [Prob], press [Set] for 5 s.</p> <p>▷ [nonE] is displayed.</p> <p>▶ Set the requested value:</p> <ul style="list-style-type: none"> • [rod] for single probe. • [COAX] for coaxial probe. <p>The detection of water and water-based media is possible with the single probe as well as with the coaxial probe.</p> <p>The detection of oils and oil-based media is only possible with the coaxial probe. Therefore the value [COAX] is preset for the parameter [Prob] when setting [MEdI] = [LOW]; the value [rod] is not available.</p>	[Prob]
---	--------

Then the device changes to the operating mode. For further parameter setting the menu can be opened. The parameters [LEnG], [MEdI] and [Prob] can be accessed and modified just like all other parameters.

9.4 Setting ranges

[LEnG]	cm
Setting range	10...160
Step increment	0.5

[OFS]	cm
Setting range	0...100
Step increment	0.5

The setting ranges for the switching limits (SPx, rPx, FHx, FLx) depend on the probe length (L). In general, the following applies:

	cm	
	min.	max.
SPx / FHx	1.5 (3.5)	L - 3
rPx / FLx	1.0 (3.0)	L - 3.5
Step increment	0.5	

The values apply if [OFS] = 0. The values in brackets apply to the setting [MEdI] = [LOW] (setting for the detection of oils and oil-based media).

- rPx is always smaller than SPx. If the value for SPx is reduced to a value \leq rPx, the position of rPx also shifts.
- If rPx and SPx are close together (about 3 x step increment), rPx is changed automatically when increasing SPx.
- If there is a greater difference between rPx and SPx, rPx maintains the set value even if SPx is increased.

9.5 Configuring the display

<ul style="list-style-type: none"> ▶ Select [SELD] and set type of indication: <ul style="list-style-type: none"> • [L] = The level is indicated in cm. • [L%] = The level is indicated in percent of the final value of the measuring range. • [OFF] = The display is switched off in the operating mode. Touching one of the buttons indicates the current measured value for 30 s. The LEDs remain active even if the display is deactivated. 	[SELD]
---	--------

9.6 Offset setting

<ul style="list-style-type: none"> ▶ Select [OFS] and enter the distance between bottom of the tank and lower edge of the probe. ▷ Afterwards, display and switch points refer to the real level. Factory setting: [OFS] = 0. 	[OFS]
---	-------



Set [OFS] before setting the switching limits (SP1/FH1, rP1/FL1). Otherwise, the switching limits shift by the value of the set offset.

9.7 Setting the output signals

9.7.1 Setting the output function

<ul style="list-style-type: none"> ▶ Select [OU1]...[OU4] and set the switching function: <ul style="list-style-type: none"> • [Hno] = hysteresis function/normally open • [Hnc] = hysteresis function/normally closed • [Fno] = window function/normally open • [Fnc] = window function/normally closed <p>Note: if the switch point is used as an overflow prevention, the setting OUx = Hnc (NC function) is recommended. The principle of normally closed operation ensures that wire break or cable break is also detected.</p>	[OU1] ... [OU4]
--	-----------------------

9.7.2 Setting the switching limits (hysteresis function)

<ul style="list-style-type: none"> ▶ Make sure that for the corresponding output [OUx] the function [Hno] or [Hnc] is set. ▶ Select [SP1]...[SP4] and set the value at which the output switches. 	[SP1] ... [SP4]
<ul style="list-style-type: none"> ▶ Select [rP1]...[rP4] and set the value at which the output is reset. <p>rPx is always smaller than SPx. The device only accepts values which are lower than the value for SPx.</p>	[rP1] ... [rP4]

9.7.3 Setting the switching limits (window function)

<ul style="list-style-type: none"> ▶ Make sure that for the corresponding output [OUx] the function [Fno] or [Fnc] is set. ▶ Select [FH1]...[FH4] and set the upper limit of the acceptable range. 	[FH1] ... [FH4]
<ul style="list-style-type: none"> ▶ Select [FL1]...[FL4] and set the lower limit of the acceptable range. <p>FLx is always lower than FHx. The device only accepts values which are lower than the value for FHx.</p>	[FL1] ... [FL4]

9.7.4 Setting the switch-off delay

<p>▶ Select [dr1]...[dr4] and set the value between 0.2 and 60 s. At 0.0 (= factory setting) the delay time is not active.</p> <p>The switch-off delay is only active if hysteresis has been set as switching function (OUx = Hno or Hnc).</p>	<p>[dr1] ... [dr4]</p>
--	--------------------------------

9.7.5 Setting the switching logic for the outputs

<p>▶ Select [P-n] and set [PnP] or [nPn].</p>	<p>[P-n]</p>
---	--------------

9.7.6 Setting response of the outputs in case of a fault

<p>▶ Select [FOU1]...[FOU4] and set the value:</p> <ul style="list-style-type: none"> • [on] = switching output switches ON in case of a fault. • [OFF] = switching output switches OFF in case of a fault. <p>Factory setting: [FOU1]...[FOU4] = [OFF].</p> <p>Faults: faulty hardware, too low a signal quality, untypical level curve. Overflow is not considered to be a fault!</p>	<p>[FOU1] ... [FOU4]</p>
---	----------------------------------

9.7.7 Setting the delay time after signal loss

<p>▶ Select [dFo] and set a value between 0.2 and 5.0 s. At 0.0 (= factory setting) the delay time is not active.</p> <p>Mind the dynamics of your application. In case of fast level changes it is recommended to adapt the value step by step.</p>	<p>[dFo]</p>
--	--------------

9.8 Resetting all parameters to factory setting

<p>▶ Select [rES], then press [Set] and keep it pressed until [----] is displayed.</p> <p>▶ Briefly press [Mode/Enter].</p> <p>▷ The device reboots and then the factory settings are restored.</p> <p>Note: on delivery the device is not operational. First, the basic settings must be entered.</p>	<p>[rES]</p>
--	--------------

9.9 Changing basic settings

Changing the basic settings is required after changes to the probe or to the application area.

9.9.1 Re-entering probe length

<p>▶ Change to menu level 2</p> <p>▶ Select [LEnG] and set probe length L. Step increment: 0.5 cm</p> <p>Remarks on the determination of the probe length:</p> <p>▶ Observe the notes on single probes or coaxial probes.</p> <p>▶ Briefly press [Mode/Enter].</p> <p>Note: after changing the probe length, the values for OFS and the switching limits must also be re-viewed / re-entered.</p>	<p>[LEnG]</p>
--	---------------

9.9.2 Setting to another medium

<p>► Select [MEd] and set the value:</p> <ul style="list-style-type: none"> • [HIGH] for water and water-based media. • [LOW] for oils and oil-based media. <p>Note: in case of doubt, carry out an application test to ensure the setting which is best for your medium.</p>	[MEd]
---	-------

9.9.3 Changing the value of the type of probe used

<p>► Select [Prob] and set the value:</p> <ul style="list-style-type: none"> • [rod] for single probe. • [COAX] for coaxial probe. <p>The detection of water and water-based media is possible with the single probe as well as with the coaxial probe.</p> <p>The detection of oils and oil-based media is only possible with the coaxial probe. Therefore, the parameter [Prob] is not available in case of the setting [MEd] = [LOW] (the value [COAX] is preset).</p>	[Prob]
---	--------

10 Operation

After power-on and expiry of the power-on delay time of approx. 0.5 s the unit is in the RUN mode (= normal operating mode). It carries out its measurement and evaluation functions and generates output signals according to the set parameters.

10.1 Operating indicators

[---] continuous	Initialisation phase after power on.
Numerical value + LED 1	Current level in cm.
Numerical value + LED 3	Current level in % of the final value of the measuring range.
LED 5...8	Switching status of the corresponding output.
[----]	Level below the active zone.
[FULL] + numerical value alternately	Level has reached or exceeded the maximum measuring range (= overflow warning).
[≡≡≡≡]	On delivery the device is not operational. ▶ Basic settings are required.
[Loc]	Device electronically locked; parameter setting impossible. ▶ For unlocking press the two setting buttons for 10 s.
[uLoc]	Device is unlocked / parameter setting is possible again.
[S.Loc]	If [S.Loc] is displayed when an attempt is made to modify a parameter value, either an IO-Link communication is active (temporary locking) or the sensor is permanently locked via software. This locking can only be removed with a parameter setting software.

10.2 Reading the set parameters

- ▶ Briefly press [Mode/Enter] to scroll the parameters.
- ▶ Briefly press [Set] to indicate the corresponding parameter value for about 30 s. After another 30 s the device returns to the Run mode.

10.3 Changing the display unit in the Run mode

Switching between length indication (cm) and percentage.

- ▶ Briefly press [Set] in the Run mode.
- ▷ The selected unit is displayed for 30 s, the corresponding LED is lit. With each push of the button the display type is changed.

10.4 Error indications

Indication	Possible cause	Recommended actions
[E.000]	Fault in the electronics.	Replace the device.
[E.031]	Probe detached from the device; possibly incorrect setting of the probe length.	Check whether the probe is still attached to the device. Check the parameter [LEnG].
[E.033]	Measurement disturbed by heavy foam build-up or turbulence.	<ul style="list-style-type: none"> • Install the device in a still pipe or bypass. • Set or increment [dFo].
	Measurement disturbed by separation layers (e.g. oil layer on water).	Remove the oil layer by suction, stir the medium, check the composition.

Indication	Possible cause	Recommended actions
[E.033]	Rod or process connection soiled.	Clean the rod and the process connection, then carry out a reset.*
	Installation conditions were not adhered to.	Observe the notes in "Installation".
	Probe length, type of probe or sensitivity (setting to the medium) is incorrect.	Correct the settings, then carry out a reset.*
[SCx]	Flashing: short circuit in switching output x.	Remove the short circuit.
[SC]	Flashing: short circuit in all switching outputs.	Remove the short circuit.
[PArA]	Faulty data set.	Reset to factory settings.

* Carry out a reset (power off and on again) after rectifying the fault to reset the error message.

10.5 Output response in different operating states

	OUT1...OUT4
Initialisation	OFF
Normal operation	according to the level and the setting of the output function (bin, OU1...OU4).
Fault (E.0xx)	OFF for FOUx = OFF; ON for FOUx = on

11 Repair, maintenance and disposal

- ▶ After use dispose of the unit in an environmentally friendly way in accordance with the applicable national regulations.
- ▶ For transport only use appropriate packaging to avoid damage of the unit.
- ▶ In case of return shipment, ensure that the unit is free from soiling, especially from dangerous and toxic substances.
- ▶ Keep the process connection free of deposits and foreign bodies.
- ▶ In case of heavy soiling:
clean the process connection and the probe at regular intervals.

In case of longer operation separation layers can form in the medium (e.g. oil on water). This applies especially to still pipes or bypasses.

- ▶ Remove the separation layers at regular intervals.
- ▶ Ensure that the vent hole (at the upper end of the coaxial pipe) remains free.
- ▶ Keep the interior of the coaxial pipe clear of foreign bodies and soiling.

12 Applications

12.1 Storage tank / level monitoring

Level monitoring with evaluation in the binary mode

- Menu setting: bin = on.
- The settings for SPx, rPx, drx and OUx are not effective.

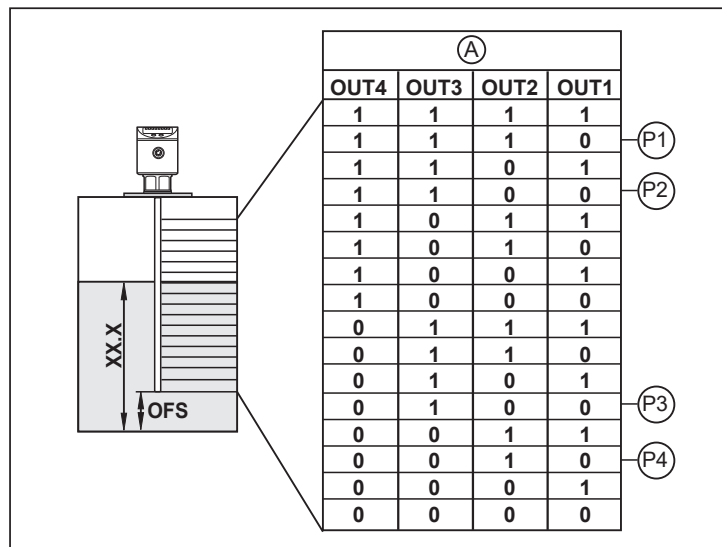

- XX.X: display value
- A: binary value
- P1: position 1, e.g. maximum value reached.
- P2: position 2, e.g. upper preset value reached.
- P3: position 3, e.g. lower preset value reached.
- P4: position 4, e.g. minimum value reached.

The binary mode corresponds to an analogue evaluation with a resolution of 6.6 % of the active zone or 4 bits.

In the evaluation electronics (PLC etc.) no analogue input is used, the analogue value is already available in digital form (8-4-2-1 binary code).

12.2 Storage tank

Level control and min / max monitoring with 4 switching outputs.

Replaces 4 float switches.

Configuration of the switching outputs 1...4 (bin = OFF).	
SP1	maximum value exceeded → alarm.
OU1	hysteresis function, normally closed (Hnc).
SP2	upper preset value exceeded → finish refilling
OU2	hysteresis function, normally open (Hno).
SP3	below lower preset value → start refilling
OU3	hysteresis function, normally closed (Hnc).
SP4	below min. value → alarm.
OU4	hysteresis function, normally open (Hno).
rP1...rP4	each slightly below SPx to suppress wave movements (factory setting).

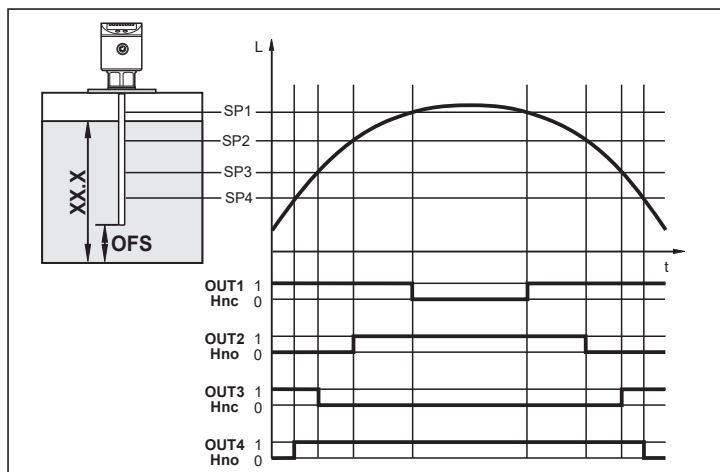

XX.X: display value

- If the level is below SP1, the output is switched. If the level is above SP1 or if there is a wire break, output 1 is reset (OFF) (alarm message "overflow / wire break").
- If the level reaches SP2, output 2 switches (upper preset value reached; finish refilling).
- If the level is below SP3, output 3 switches (below lower preset value; start refilling).
- If the level is above SP4, the output is switched. If the level is below SP4 or if there is a wire break, output 4 is reset (OFF) (alarm message "below min. value / wire break").

13 Factory setting

	Factory setting	User settings
SP1 / FH1	25% SP/FHmax	
rP1 / FL1	25% rP/FLmax	
OU1	Hno	
SP2 / FH2	50% SP/FHmax	
rP2 / FL2	50% rP/FLmax	
OU2	Hno	
SP3 / FH3	75% SP/FHmax	
rP3 / FL3	75% rP/FLmax	
OU3	Hno	
SP4 / FH4	100% SP/FHmax	
rP4 / FL4	100% rP/FLmax	
OU4	Hnc	
OFS	0.0	
dr1	0.0	
dr2	0.0	
dr3	0.0	
dr4	0.0	
FOU1	OFF	
FOU2	OFF	
FOU3	OFF	
FOU4	OFF	
dFo	0	
P-n	PnP	
SELD	L	
LEnG	nonE	
MEdl	nonE	
Prob	nonE	
bin	OFF	

SP/FHmax = LEnG value minus 3.

rP/FLmax = LEnG value minus 3.5.

When the LEnG value is entered, the program calculates the basic setting.