

ENCO-METER EM8

EXTENDIBLE CABLE MEASUREMENT SYSTEM

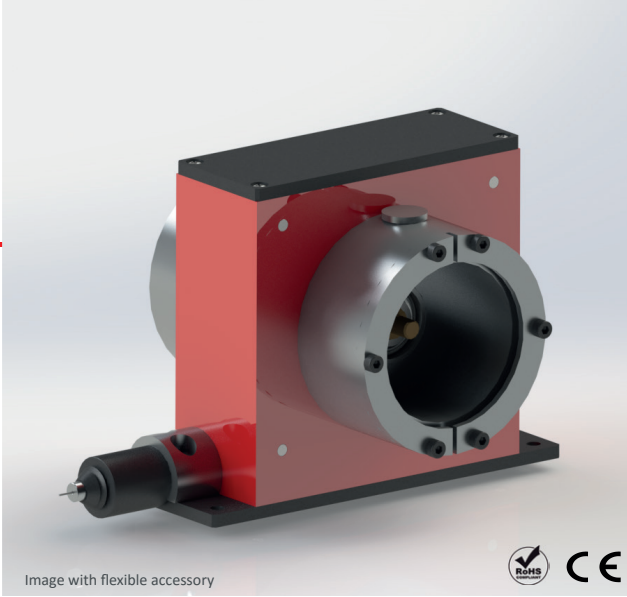

Image with flexible accessory

- Measuring linear distances up to 8 meters
- Any mounting position possible
- Protection class IP51 according to DIN EN 60529
- Anodised and pressurized options available
- The drum shaft can drive any kind of rotary encoder (encoder, potentiometer, ...)
- Stainless steel extendible cable $\varnothing 0,61$ AISI316



Linear measurement system



Extendible cable



45°



Pressurized



IP 51



Express Delivery

90.1808

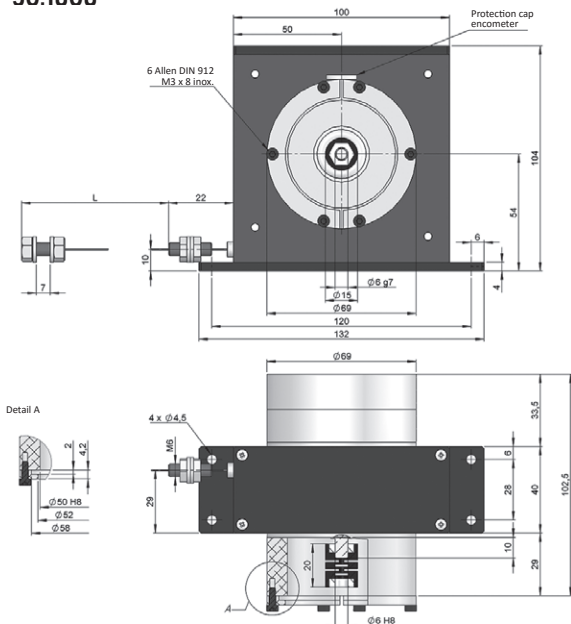

Drawing 90.1808 with standard bell synchro and coupling type 1

90.1808.FX

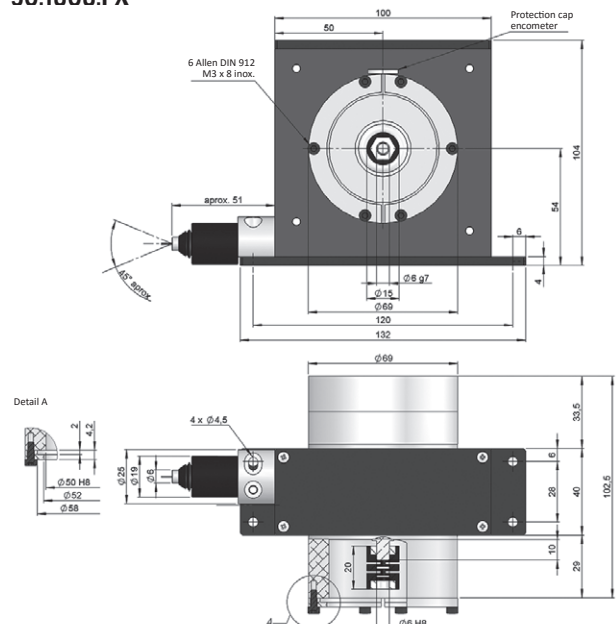

Drawing 90.1808.FX with flexible accessory, standard bell synchro and coupling type 1

REFERENCE

Reference example: 90.1808.SY1

Serie	Fixing system to sensor	Coupling	Special Customer
90.1808 / 90.1808.FX	<input type="checkbox"/> <input type="checkbox"/>	<input type="checkbox"/>	<input type="checkbox"/> <input type="checkbox"/>
90.1808. Standard	SY. Standard bell synchro	1. PFP 1520 06/06	AW. Inverted caps
90.1808.FX. Flexible accessory	CL. Clamping bell	2. PFP 1520 06/635 3. PFP 2224 06/10	BF. Anodised BD. Pressurized

Request the ENCO-METER already coupled to an electronic output device that could be an Incremental Optical Encoder, Multiturn Absolute Optical Encoder, Potentiometer or Multiturn Absolute Magnetic Encoder.



ENCO-METER EM8

EXTENDIBLE CABLE MEASUREMENT SYSTEM

TECHNICAL SPECIFICATIONS

MODEL	EM8
Reference	90.1808 / 90.1808.FX
Travel	250 mm ±0,06 / per turn
Cable*	Ø 0,61 stainless steel AISI316 (structure 19 x 7 + 0)
Measurement range, up to (mm)	8000
Maximum cable extension (mm)	8010
Minimum cable static tension	6 N - Standard
Maximum cable static tension	13 N - Standard
Maximum extension acceleration	30 m/s ² - Standard
Maximum recovery acceleration	12 m/s ² - Standard
Maximum speed	0,75 m/s
Protection against dust and splashes according to DIN EN 60529	IP51

(*) Other types of cables are possible on special order.

FLEXIBLE ACCESSORY (FX)

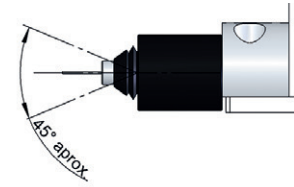

ENCO-METERS with flexible accessory FX (90.1404.FX, 90.1808.FX, 90.1810.FX) allow a misalignment of the extendable cable up to 45°.

INSTALLATION

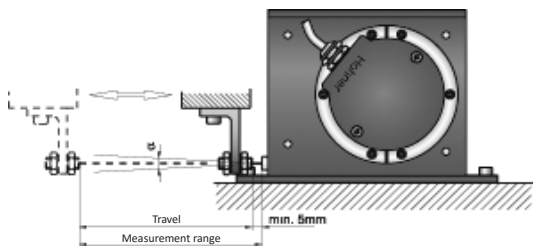

ENCO-METER units are secured to a flat machine surface by means of three or four M4 screws. The cable must be correctly aligned and under no circumstances must it exceed the measurement range.

Special customer AW for inverted caps.

EM 90.1808: $\alpha < 2^\circ$ | EM 90.1808.FX: $\alpha < 45^\circ$

OUTPUT DEVICES

We can supply the ENCO-METER already coupled to an electronic output device that could be an Incremental Optical Encoder, Multiturn Absolute Optical Encoder, Potentiometer or Multiturn Absolute Magnetic Encoder:

+ ABSOLUTE OR INCREMENTAL ENCODER

If it is required to obtain a determined resolution "r" (mm per pulse) in the case of using an absolute or incremental encoder, the number of encoder pulses (n) will be:

$$n = \frac{D}{r} \quad (D \text{ is ENCO-METER travel in mm})$$

+ POTENTIOMETER

Using a potentiometer, an output "r" ratio (in Ω per mm) is obtained in accordance with:

$$r = \frac{R}{D \cdot n} \quad (R \text{ is the rated resistance and } n \text{ is the maximum number of turns})$$

As standard, we have potentiometers of $R = 10k\Omega$ and $n = 10$ turns. It must be taken into consideration that the mechanical travel of the potentiometer may limit the ENCO-METER measurement range.

i Electronic output devices that are delivered coupled to an ENCO-METER have an orientation of 45°.

i If devices are not supplied assembled, we recommend mounting the sensor on the ENCO-METER without the seal.

ENCO-METER EM8

EXTENDIBLE CABLE MEASUREMENT SYSTEM

FIXING SENSOR SYSTEM DIMENSIONS

Fixing system to
sensor type CL
Clamping bell

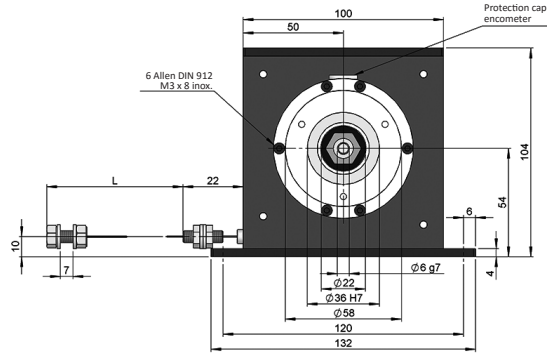

Coupling type 3
PFP 2224 06/10

SPECIAL CUSTOMER OPTIONS

AW - Inverted caps

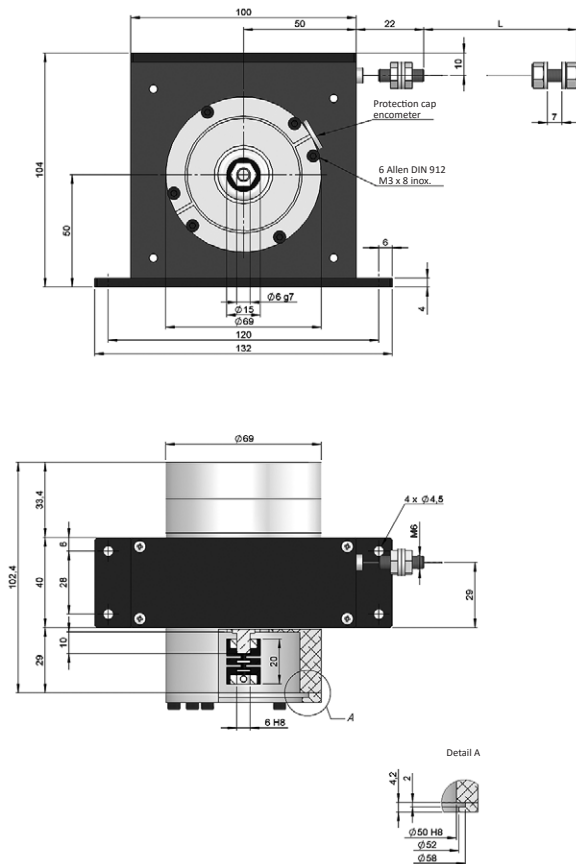

Drawing 90.1808, Special Customer AW

BD - Pressurized option

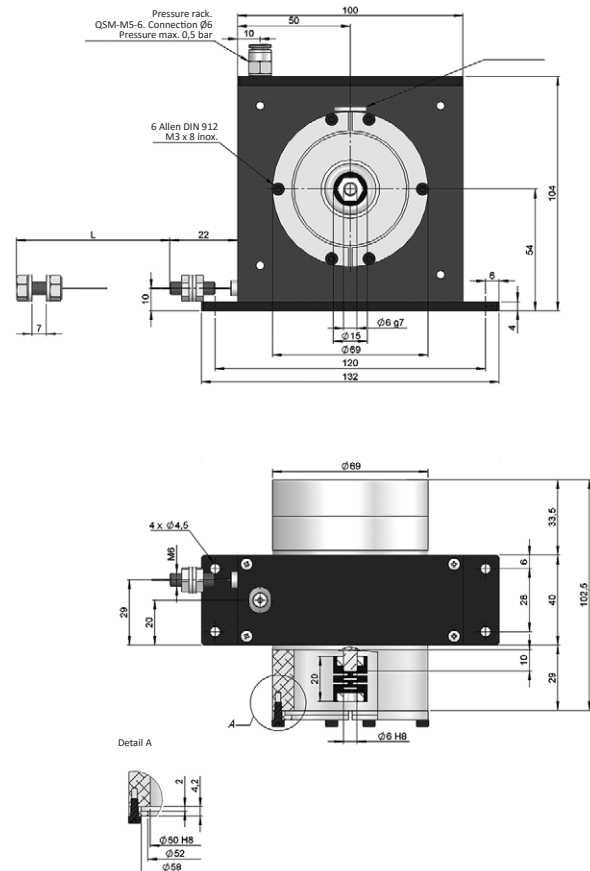

Drawing 90.1808, Special Customer BD