

P1KHxxx

Reflex Sensors with Background Suppression



Operating Instructions

Table of Contents

1. General	3
1.1 Information Concerning these Instructions	3
1.2 Explanations of Symbols	3
1.3 Limitation of Liability	4
1.4 Copyrights	4
2. For Your Safety	5
2.1 Use for Intended Purpose	5
2.2 Use for Other than the Intended Purpose	5
2.3 Personnel Qualifications	6
2.4 Modification of Products	6
2.5 General Safety Precautions	6
2.6 Laser/LED Warnings	6
2.7 Approvals and protection class	7
3. Technical Data	7
3.7.1 Spot Diameter	10
3.7.2 Switching Distance Deviation	10
3.1 Complementary Products	11
3.2 Layout	12
3.3 Control Panel	15
3.4 Scope of Delivery	16
4. Transport and Storage	16
4.1 Transport	16
4.2 Storage	16
5. Installation and Electrical Connection	17
5.1 Installation	17
5.2 Electrical Connection	18
5.3 Diagnostics	19
6. Settings	21
6.1 Object Detection Directly in Front of a Background or an Undersurface	21
6.2 Detection of Objects Without Interfering Background	21
7. IO-Link	21
8. Maintenance Instructions	22
9. Proper Disposal	22
10. Appendix	22
10.1 List of Abbreviations	22
10.2 Change Index, Operating Instructions	22
10.3 EU Declaration of Conformity	22

1. General

1.1 Information Concerning these Instructions

- These instructions apply to the products with ID code P1KHxxx.
- They make it possible to use the product safely and efficiently.
- These instructions are an integral part of the product and must be kept on hand for the entire duration of its service life.
- Local accident prevention regulations and national work safety regulations must be complied with as well.
- The product is subject to further technical development, and thus the information contained in these operating instructions may also be subject to change. The current version can be found at www.wenglor.com in the product's separate download area.



NOTE!

The operating instructions must be read carefully before using the product and must be kept on hand for later reference.

1.2 Explanations of Symbols

- Safety precautions and warnings are emphasized by means of symbols and attention-getting words
- Safe use of the product is only possible if these safety precautions and warnings are adhered to

The safety precautions and warnings are laid out in accordance with the following principle:



Attention-Getting Word! Type and Source of Danger!

Possible consequences in the event that the hazard is disregarded.

- Measures for averting the hazard.

The meanings of the attention-getting words, as well as the scope of the associated hazards, are listed below.



DANGER!

This word indicates a hazard with a high degree of risk which, if not avoided, results in death or severe injury.



WARNING!

This word indicates a hazard with a medium degree of risk which, if not avoided, may result in death or severe injury.



CAUTION!

This word indicates a hazard with a low degree of risk which, if not avoided, may result in minor or moderate injury.



ATTENTION!

This word draws attention to a potentially hazardous situation which, if not avoided, may result in property damage.



NOTE!

A note draws attention to useful tips and suggestions, as well as information regarding efficient, error-free use.

1.3 Limitation of Liability

- The product has been developed in consideration of the current state-of-the-art and applicable standards and guidelines. Subject to change without notice.
- A valid declaration of conformity can be accessed at www.wenglor.com in the product's separate download area.
- wenglor sensoric elektronische Geräte GmbH (hereinafter referred to as "wenglor") excludes all liability in the event of:
 - Non-compliance with the instructions
 - Use of the product for purposes other than those intended
 - Use by untrained personnel
 - Use of unapproved replacement parts
 - Unapproved modification of products
- These operating instructions do not include any guarantees from wenglor with regard to the described procedures or specific product characteristics.
- wenglor assumes no liability for printing errors or other inaccuracies contained in these operating instructions, unless wenglor was verifiably aware of such errors at the point in time at which the operating instructions were prepared.

1.4 Copyrights

- The contents of these instructions are protected by copyright law.
- All rights are reserved by wenglor.
- Commercial reproduction or any other commercial use of the provided content and information, in particular graphics and images, is not permitted without previous written consent from wenglor.

2. For Your Safety

2.1 Use for Intended Purpose

The product is based on the following functional principle:

Reflex Sensors with Background Suppression

Reflex sensors with background suppression analyze the light reflected from objects. As these sensors work according to the principle of angular measurement, the color, shape and surface characteristics of the object have almost no influence on the detection range. Even dark objects can be reliably detected against a bright background. The output is switched as soon as an object passes the selected range.

This product can be used in the following industry sectors:

- Special machinery manufacturing
- Heavy machinery manufacturing
- Logistics
- Automotive industry
- Food industry
- Packaging industry
- Pharmaceuticals industry
- Plastics industry
- Woodworking industry
- Consumer goods industry
- Paper industry
- Electronics industry
- Glass industry
- Steel industry
- Aviation industry
- Chemicals industry
- Alternative energy
- Raw materials extraction

2.2 Use for Other than the Intended Purpose

- Not a safety component in accordance with 2006/42/EC (Machinery Directive)
- The product is not suitable for use in potentially explosive atmospheres.
- The product may only be used with accessories supplied or approved by wenglor, or combined with approved products. A list of approved accessories and combination products can be accessed at www.wenglor.com on the product detail page.

DANGER!



Risk of personal injury or property damage in case of use for other than the intended purpose!

- Use for other than the intended purpose may lead to hazardous situations.
- Observe instructions regarding use for intended purpose.
-

2.3 Personnel Qualifications

- Suitable technical training is a prerequisite.
- In-house electronics training is required.
- Trained personnel must have uninterrupted access to the operating instructions.



DANGER!

Risk of personal injury or property damage in case of incorrect initial start-up and maintenance!

- Personal injury and damage to equipment may occur.
- Adequate training and qualification of personnel.

2.4 Modification of Products



DANGER!

Risk of personal injury or property damage if the product is modified!

- Personal injury and damage to equipment may occur. Non-observance may result in loss of the CE marking and the guarantee may be rendered null and void.
- Modification of the product is impermissible.

2.5 General Safety Precautions



NOTE!

- These instructions are an integral part of the product and must be kept on hand for the entire duration of its service life.
- In the event of possible changes, the respectively current version of the operating instructions can be accessed at www.wenglor.com in the product's download area.
- Read the operating instructions carefully before using the product.
- Protect the sensor against contamination and mechanical influences.

2.6 Laser/LED Warnings

The respective laser class or LED group is listed in the product's technical data.



Laser Class 1 (EN 60825-1)

Applicable standards and safety regulations must be observed.



Laser Class 2 (EN 60825-1)

Applicable standards and safety regulations must be observed. The enclosed laser warning labels must be attached and visible at all time. Do not stare into beam.

2.7 Approvals and protection class



3. Technical Data

Optical Data	
Service life (ambient temp. = +25 °C)	100000 h
Max. permissible ambient light	10000 Lux
Electrical Data	
Supply power	10...30 V DC
IO-Link supply voltage	18...30 V DC
Temperature range	-40...60 °C
Switching output voltage drop	< 2 V
Switching output switching current	100 mA
Switching output residual current	< 50 µA
Short-circuit protection	Yes
Reverse polarity protected	Yes
Overload-proof	Yes
Lockable	Yes
Interface	IO-Link
IO-Link version	1.1
Protection class	III
Mechanical Data	
Setting method	Potentiometer
Housing material	Plastic
Degree of protection	IP67 / IP68
Lens cover	PMMA

Order Number		P1KH																
Technical Data		001	002	003	023	004	018	005	020	013	014	010	025	011	026	012	027	
Range		150 mm										300 mm						
Adjustable Range		30...150 mm										30...300 mm						
Switching Hysteresis		<10 %										<5 %						
Light Source		Red Light																
Laser Class (EN 60825-1)		—																
Spot Diameter		see Table 1										see Table 2						
Current consumption		< 20 mA																
Switching frequency		1000 Hz																
Response time		0,5 ms																
Switching frequency (Interference-free-Mode)		500 Hz																
Response time (Interference-free-Mode)		1 ms																
Temperature drift		< 5 %										< 5 %*						
Setting method		Potentiometer										Potentiometer (Multi-turn)						
Output function	PNP	x	x	x		x		x				x		x		x		
	NPN				x		x		x	x	x		x		x		x	
	NC, NO antivalent	x	x	x	x						x	x	x	x	x			
	NO					x	x										x	x
	NC								x	x								
Connection		Cable, 2 m	M8×1	M12×1	M12×1	M8×1					Cable, 2 m	M8×1	M8×1	M12×1	M12×1	M8×1		
Connection diagram No.		214	215	213	216	171	217	218	213	212	215	213	215	213	216	171		
Suitable mounting technology No.		—	7	2	2	8			7	—	7	7	2	2	8	8		

* For the sensors P1KH010-P1KH012 the Temperature drift is depending on the ambient temperature:
 Temperature drift (0 °C < Tu < 40 °C): < 5 %
 Temperature drift (-20 °C < Tu < 0 °C, 40 °C < Tu < 50 °C): < 10 %
 Temperature drift (Tu < -20 °C, Tu > 50 °C): < 13 %

P1KH									
019	022	006	007	028	008	029	015	009	030
150 mm		120 mm							
30...150 mm		30...120 mm							
<10 %									
Blue Light		Laser (red)							
—		1						2	
see Table 3		see Table 4							
< 20 mA		< 15 mA							
1000 Hz									
0,5 ms									
500 Hz									
1 ms									
< 5 %									
Potentiometer									
×		×	×		×			×	
	×			×		×	×		×
×	×	×	×	×			×	×	×
					×	×			
M8×1		M12×1	M12×1	M8×1					
215	213	215	213	216	171	213	215	213	
7		2	2	8	8	7			

3.7.1 Spot Diameter

Range	50 mm	100 mm	150 mm
Spot diameter	5 mm	7 mm	10 mm

Table 1

Range	30 mm	130 mm	300 mm
Spot diameter	8 mm	7 mm	18 mm

Table 2

Range	50 mm	100 mm	150 mm
Spot diameter	5 mm	7 mm	10 mm

Table 3

Range	40 mm	80 mm	120 mm
Spot diameter	2,5 mm	1,5 mm	1 mm

Table 4

3.7.2 Switching Distance Deviation

Typical characteristic curve based on Kodak white (90 % remission).

P1KH001 – P1KH005, P1KH013, P1KH014,
P1KH018, P1KH020, P1KH023:

P1KH006 – P1KH009, P1KH015, P1KH028 – P1KH030:

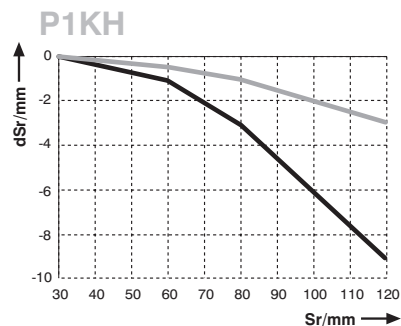
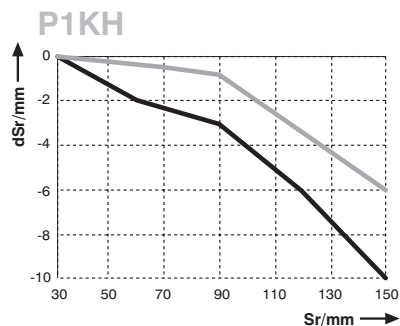

P1KH019, P1KH022:

P1KH010–P1KH012, P1KH0025–P1KH027:

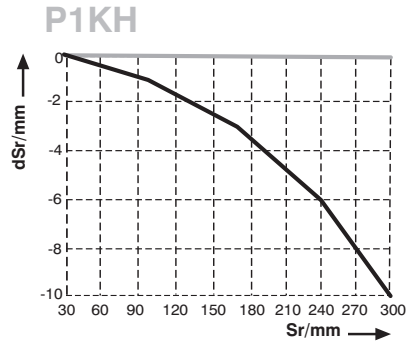
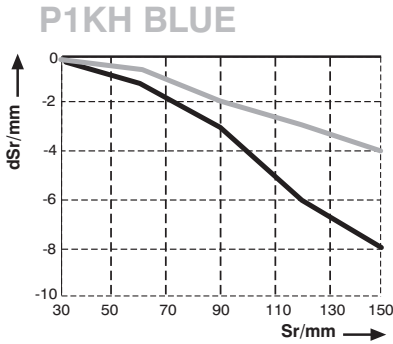

Sr = Switching Distance
dSr = Switching Distance Change
Black 6 % remission
Grey 18 % remission

3.1 Complementary Products

wenglor can provide you with suitable connection technology for your product.

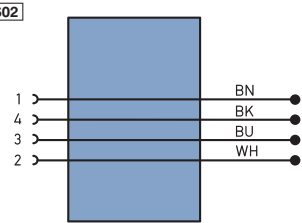
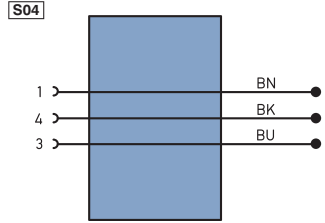
Suitable mounting technology no.	400
Suitable connection technology no.	7 2 8
	<div style="display: flex; justify-content: space-around;"> <div style="text-align: center;"> <p>S02</p>  </div> <div style="text-align: center;"> <p>S04</p>  </div> </div>
PNP-NPN converter BG7V1P-N-2M	
IO-Link master	
wTeach2 software DNNF005	

3.2 Layout

P1KH002, P1KH004, P1KH005, P1KH013, P1KH018, P1KH019, P1KH020, P1KH022

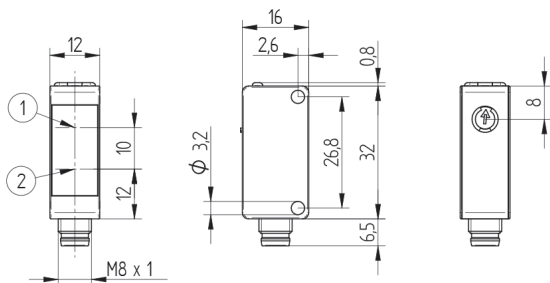

P1KH001, P1KH014

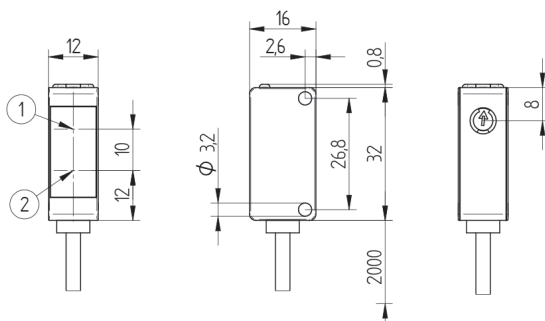

P1KH003, P1KH023

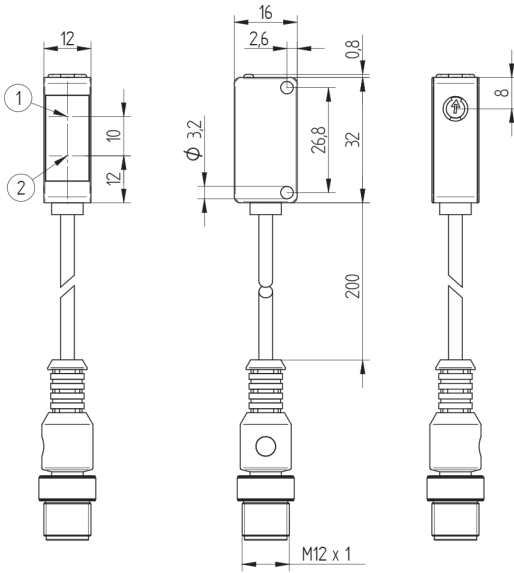

P1KH010, P1KH012, P1KH025, P1KH027

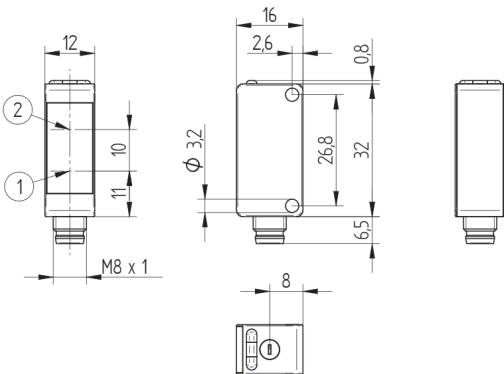

P1KH011, P1KH026

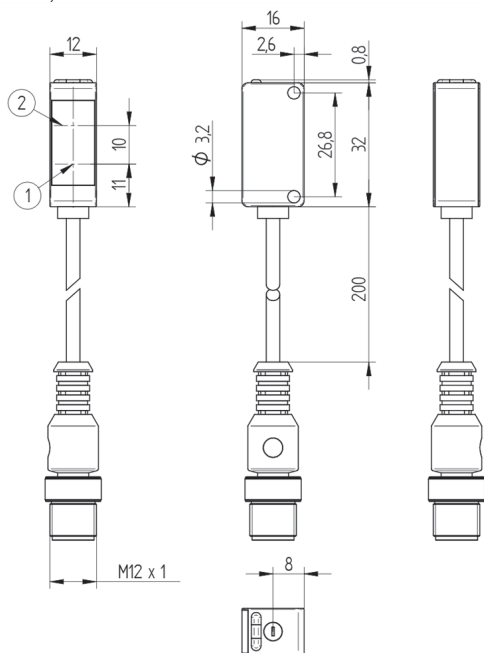

P1KH006, P1KH008, P1KH009, P1KH015, P1KH029, P1KH030

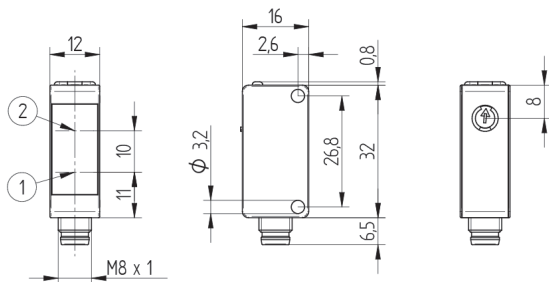

P1KH007, P1KH028

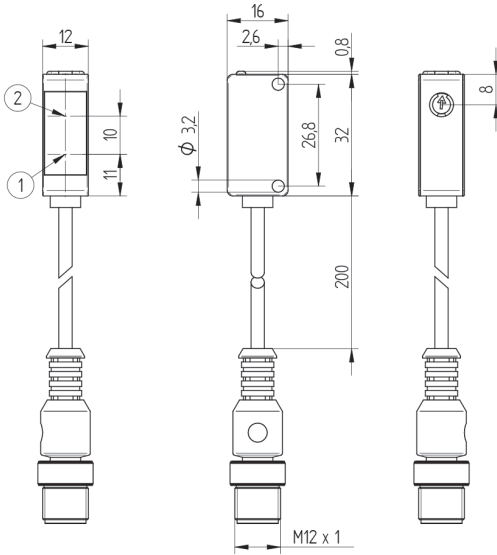

① = Emitter diode
 ② = Receiving diode
 Screw M3 = 0,5 Nm
 Potentiometer = 40 Nmm
 Dimensions specified in mm (1 mm = 0,03937 Inch)

3.3 Control Panel

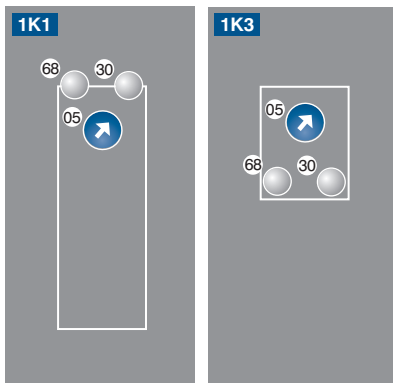

05 = switching distance adjuster
 30 = switching status indicator / contamination warning
 68 = supply power indicator

3.4 Scope of Delivery

- Sensor
- Safety precautions
- Laser warning label (for Class 2)
- Mounting-Set 01

4. Transport and Storage

4.1 Transport

Upon receipt of shipment, the goods must be inspected for damage in transit. In the case of damage, conditionally accept the package and notify the manufacturer of the damage. Then return the device, making reference to damage in transit.

4.2 Storage

The following points must be taken into condition with regard to storage:

- Do not store the product outdoors.
- Store the product in a dry, dust-free place.
- Protect the product against mechanical impacts.
- Protect the product against exposure to direct sunlight.



ATTENTION!

Risk of property damage in case of improper storage!

The product may be damaged.

- Storage instructions must be complied with.
-

5. Installation and Electrical Connection

5.1 Installation

- Protect the product from contamination during installation.
- Observe all applicable electrical and mechanical regulations, standards, and safety rules.
- Protect the product against mechanical influences.
- Make sure that the sensor is mounted in a mechanically secure fashion.
- Specified torque values must be complied with ([see section “3. Technical Data”, page 7](#)).

ATTENTION!



Risk of property damage in case of improper installation!

The product may be damaged.

- Installation instructions must be complied with.

CAUTION!



Risk of personal injury or property damage during installation!

Personal injury and damage to the product may occur.

- A safe installation environment must be assured.
-

5.2 Electrical Connection

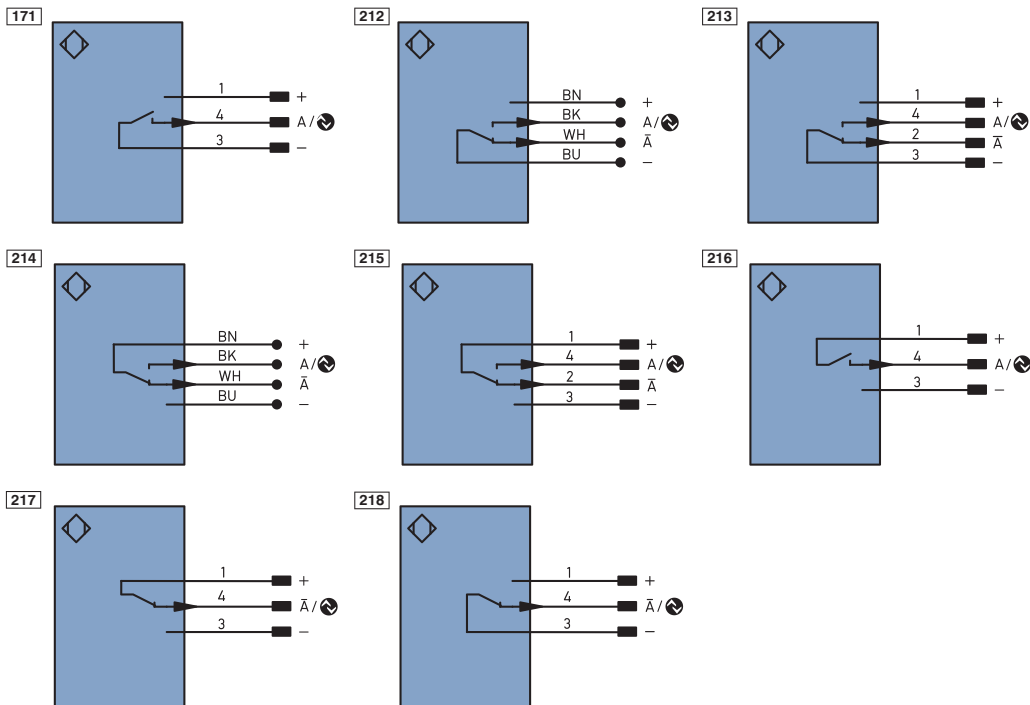

Legend

+	Supply Voltage +
-	Supply Voltage 0 V
-	Supply Voltage (AC Voltage)
A	Switching Output (NO)
A̅	Switching Output (NC)
V	Contamination/Error Output (NO)
V̅	Contamination/Error Output (NC)
E	Input (analog or digital)
T	Teach Input
Z	Time Delay (activation)
S	Shielding
RxD	Interface Receive Path
TxD	Interface Send Path
RDY	Ready
GND	Ground
CL	Clock
E/A	Output/Input programmable
	IO-Link
PoE	Power over Ethernet
IN	Safety Input
OSSD	Safety Output
Signal	Signal Output
BI_D+/-	Ethernet Gigabit bidirect. data line (A-D)
EN _{RS422}	Encoder 0-pulse 0-0̅ (TTL)

PT	Platinum measuring resistor
nc	not connected
U	Test Input
Ū	Test Input inverted
W	Trigger Input
W-	Ground for the Trigger Input
O	Analog Output
O-	Ground for the Analog Output
BZ	Block Discharge
AWV	Valve Output
a	Valve Control Output +
b	Valve Control Output 0 V
SY	Synchronization
SY-	Ground for the Synchronization
E+	Receiver-Line
S+	Emitter-Line
⊕	Grounding
SnR	Switching Distance Reduction
Rx+/-	Ethernet Receive Path
Tx+/-	Ethernet Send Path
B _{us}	Interfaces-Bus A(+)/B(-)
La	Emitted Light disengageable
Mag	Magnet activation
RES	Input confirmation
EDM	Contacting Monitoring

EN _{RS422}	Encoder A/A̅ (TTL)
EN _{RS422}	Encoder B/B̅ (TTL)
ENA	Encoder A
ENa	Encoder B
AMIN	Digital output MIN
AMAX	Digital output MAX
AOK	Digital output OK
SY In	Synchronization In
SY OUT	Synchronization OUT
0LT	Brightness output
M	Maintenance
rsv	reserved
Wire Colors according to IEC 60757	
BK	Black
BN	Brown
RD	Red
OG	Orange
YE	Yellow
GN	Green
BU	Blue
VT	Violet
GY	Grey
WH	White
PK	Pink
GNYE	Green/Yellow

DANGER!



Risk of personal injury or property damage due to electric current!

Voltage conducting parts may cause personal injury or damage to equipment.

- The electric device may only be connected by appropriately qualified personnel.

5.3 Diagnostics

Causes for Triggering the Contamination Warning (blinking LED):

Display LED	Diagnosis/Cause	Elimination
Continuous blinking at approx. 2.5 Hz	Contamination	Carefully clean the optic cover with a cloth.
	Aged emitter diode	Replace the sensor.
	Unreliable working range	<ul style="list-style-type: none"> • Increase the sensor's switching distance. • Reduce distance between sensor and object.
Continuous blinking at approx. 5 Hz	Short-circuit	Check electrical wiring and eliminate the short-circuit.
	Over-temperature	Disconnect the sensor from supply power and allow it to cool down.
	Hardware error	Replace the sensor.

Contamination Warning Flowcharts

Reflex Mode		no contamination		
Object		not detected	detected	not detected
Switching Status Indicator		off <input type="radio"/>	on <input checked="" type="radio"/>	off <input type="radio"/>
beginning contamination				
Object		not detected	detected	not detected
Switching Status Indicator		off <input type="radio"/>	blinking <input checked="" type="radio"/>	off <input type="radio"/>
advanced contamination				
Object		not detected	not detected	not detected
Switching Status Indicator		off <input type="radio"/>	off <input type="radio"/>	off <input type="radio"/>

Required action in case of fault:



NOTE!

- Shut down the machine.
- Analyze and eliminate the cause of error with the help of the diagnostics information.
- If the error cannot be eliminated, please contact wenglor's support department.
- Do not operate in case of indeterminate malfunctioning.
- The machine must be shut down if the error cannot be unequivocally clarified or reliably eliminated.



DANGER!

Risk of personal injury or property damage in case of non-compliance!

The system's safety function is disabled. Personal injury and damage to equipment.

- Required action as specified in case of fault.

6. Settings

6.1 Object Detection Directly in Front of a Background or an Undersurface

- Adjust and securely mount the sensor such that the spot strikes the object to be detected at a right angle.
- Turn the potentiometer all the way to the right.
- Remove the object and slowly turn the potentiometer back until the output is switched. The background or the undersurface is now suppressed.
- Put the object back under the spot and check to determine whether or not the sensor is activated again.

6.2 Detection of Objects Without Interfering Background

- Adjust and securely mount the sensor such that the spot strikes the object to be detected.
- Turn the potentiometer all the way to the left.
- Turn up the potentiometer up until activation occurs and, if required, turn it up a bit further for increased switching reliability.

7. IO-Link

Further settings are possible via the IO-Link interface. The IODD can be found at www.wenglor.com in the product's download area.

8. Maintenance Instructions



NOTE!

- This wenglor sensor is maintenance-free.
- Cleaning and inspection of the plug connections at regular intervals are advisable.
- Do not clean the sensor with solvents or cleansers which could damage the product.
- The product must be protected against contamination during initial start-up.

9. Proper Disposal

wenglor sensoric GmbH does not accept the return of unusable or irreparable products. Respectively valid national waste disposal regulations apply to product disposal.

10. Appendix

10.1 List of Abbreviations

Abbreviation	Meaning
Tu	Ambient temperature
Ub	Supply voltage
IODD	IO Device Description
MTTFd	Mean Time to Dangerous Failure

10.2 Change Index, Operating Instructions

Version	Date	Description/Change
1.0.0	28.06.17	Initial version of the operating instructions
1.1.0	06.12.17	“3. Technical Data” on page 7
1.2.0	21.11.18	Switching Hysteresis in “3. Technical Data”
1.3.0	25.06.19	“2.6 Laser/LED Warnings” on page 6

10.3 EU Declaration of Conformity

The EU declaration of conformity can be found on our website at www.wenglor.com in the product's download area.

