

High-Performance Distance Sensor

CP24MHT80 LASER

Part Number



- High resolution: 20 μm (resolution-mode)
- Linearity: 0,1 % (resolution-mode)
- Measured value independent of material, color and brightness
- Response time: < 660 μs (speed-mode)
- Zoom function

These sensors work with a high-resolution CMOS line and DSP technology and determine distance using angular measurement. As a result, material, color and brightness related measurement differences are virtually eliminated.

Integrated analogue output can be configured for voltage 0...10 V (10...0 V) or current 4...20 mA (20...4 mA).

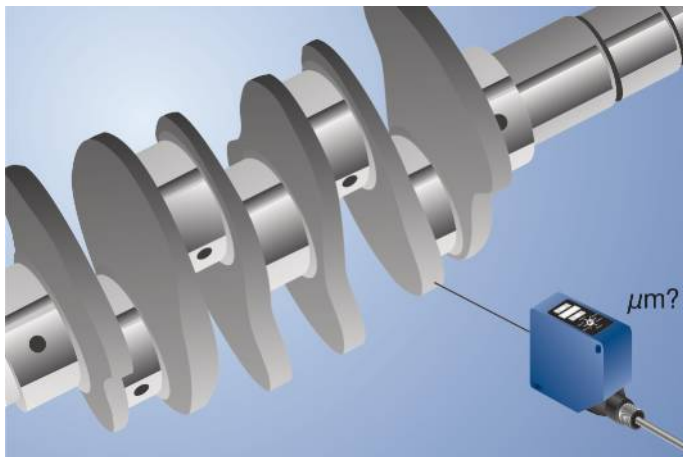

Technical Data

Optical Data	
Working Range	40...160 mm
Measuring Range	120 mm
Resolution	20 μm
Resolution (Speed-Mode)	30 μm
Linearity	0,1 %
Linearity (Speed-Mode)	0,2 %
Light Source	Laser (red)
Wavelength	660 nm
Service Life (T = +25 °C)	100000 h
Laser Class (EN 60825-1)	2
Max. Ambient Light	10000 Lux
Light Spot Diameter	see Table 1
Electrical Data	
Supply Voltage	18...30 V DC
Current Consumption (U _b = 24 V)	< 80 mA
Measuring Rate	1500 /s
Measuring Rate (Resolution-Mode)	600 /s
Response Time	< 660 μs
Response Time (Resolution Mode)	< 1660 μs
Temperature Drift	< 10 $\mu\text{m}/\text{K}$
Temperature Range	-25...50 °C
Analog Output	0...10 V/4...20 mA
Load Current Voltage Output	< 1 mA
Current Output Load Resistance	< 500 Ohm
Interface	RS-232
Baud Rate	38400 Bd
Protection Class	III
FDA Accession Number	0820589-000
Mechanical Data	
Setting Method	Teach-In
Housing Material	Plastic
Degree of Protection	IP67
Connection	M12 × 1; 8-pin
Error Output	●
Analog Output	●
RS-232 Interface	●
Connection Diagram No.	529
Control Panel No.	P7
Suitable Connection Equipment No.	80
Suitable Mounting Technology No.	380

Complementary Products

Analog Evaluation Unit AW02	
Fieldbus Gateway ZAGxxxN01, EPGG001	
Interface Cable S232W3	
Protective Housing ZSV-0x-01	
Set Protective Housing ZSP-NN-02	
Software	

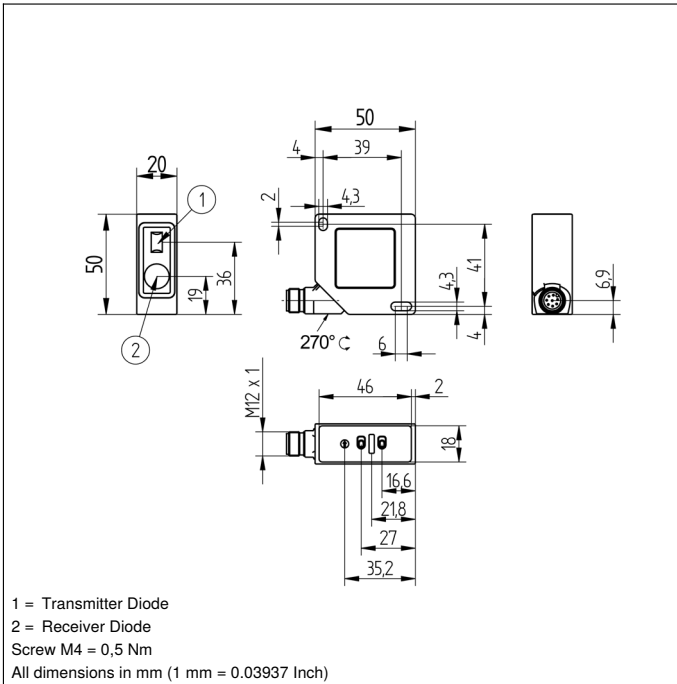

Ctrl. Panel

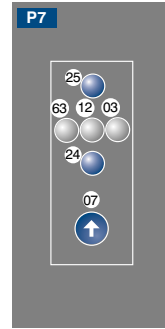

- 03 = Error Indicator
- 07 = Selector Switch
- 12 = Analog Output Indicator
- 24 = Plus Button
- 25 = Minus Button
- 63 = Analog Output Current Indicator

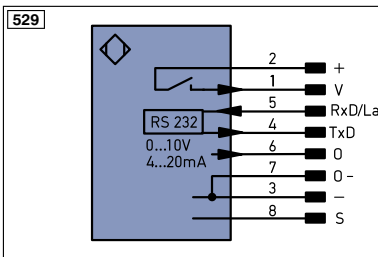

Legend		Legend		Legend	
+	Supply Voltage +	PT	Platinum measuring resistor	EN ^A RS422	Encoder A/A (TTL)
-	Supply Voltage 0 V	nc	not connected	EN ^B RS422	Encoder B/B (TTL)
~	Supply Voltage (AC Voltage)	U	Test Input	EN ^A	Encoder A
A	Switching Output (NO)	U	Test Input inverted	EN ^B	Encoder B
Ā	Switching Output (NC)	W	Trigger Input	A _{MIN}	Digital output MIN
V	Contamination/Error Output (NO)	W-	Ground for the Trigger Input	A _{MAX}	Digital output MAX
ṽ	Contamination/Error Output (NC)	O	Analog Output	A _{OK}	Digital output OK
E	Input (analog or digital)	O-	Ground for the Analog Output	SY _{in}	Synchronization In
T	Teach Input	BZ	Block Discharge	SY _{OUT}	Synchronization OUT
Z	Time Delay (activation)	AWV	Valve Output	OLT	Brightness output
S	Shielding	a	Valve Control Output +	M	Maintenance
RxD	Interface Receive Path	b	Valve Control Output 0 V	rsv	reserved
TxD	Interface Send Path	SY	Synchronization	Wire Colors according to DIN IEC 757	
RDY	Ready	SY-	Ground for the Synchronization	BK	Black
GND	Ground	E+	Receiver-Line	BN	Brown
CL	Clock	S+	Emitter-Line	RD	Red
E/A	Output/Input programmable	±	Grounding	OG	Orange
	IO-Link	S _n R	Switching Distance Reduction	YE	Yellow
PoE	Power over Ethernet	Rx+/-	Ethernet Receive Path	GN	Green
IN	Safety Input	Tx+/-	Ethernet Send Path	BU	Blue
OSSD	Safety Output	Bus	Interfaces-Bus A(+)/B(-)	VT	Violet
Signal	Signal Output	La	Emitted Light disengageable	GY	Grey
Bl_D+/-	Ethernet Gigabit bidirect. data line (A-D)	Mag	Magnet activation	WH	White
EN ⁰ RS422	Encoder 0-pulse 0-0 (TTL)	RES	Input confirmation	PK	Pink
		EDM	Contacting Monitoring	GNVE	Green/Yellow

Table 1

Working Distance	40 mm	160 mm
Spot Size	0,5 x 1,2 mm	1 x 2,5 mm

Output Graph

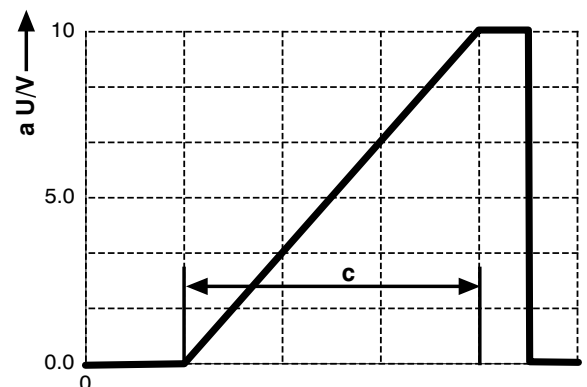

c = Measuring Range

a = Analog Voltage Output

