

# P1KY10x

High-Performance Distance Sensors



## Operating Instructions

# Table of Contents

<b>1. General</b>	<b>3</b>
1.1 Information Concerning these Instructions	3
1.2 Explanations of Symbols	3
1.3 Limitation of Liability	4
1.4 Copyrights	4
<b>2. For Your Safety</b>	<b>5</b>
2.1 Use for Intended Purpose	5
2.2 Use for Other than the Intended Purpose	5
2.3 Personnel Qualifications	6
2.4 Modification of Products	6
2.5 General Safety Precautions	6
2.6 Laser/LED Warnings	6
2.7 Approvals and protection class	6
<b>3. Technical Data</b>	<b>7</b>
3.1 Spot diameter	8
3.2 Switching Distance Deviation	8
3.3 Accessory Products	8
3.4 Layout	9
3.5 Control Panel	10
3.6 Scope of Delivery	10
<b>4. Transport and Storage</b>	<b>10</b>
4.1 Transport	10
4.2 Storage	10
<b>5. Installation and Electrical Connection</b>	<b>11</b>
5.1 Installation	11
5.2 Electrical Connection	11
5.3 Diagnostics	12
<b>6. Settings</b>	<b>14</b>
<b>7. Settings via IO-Link</b>	<b>15</b>
7.1 Background Teach-In	15
7.2 Window Teach-In	15
7.3 Locking	16
7.4 External Teach-In	16
7.5 Error Output	16
<b>8. IO-Link</b>	<b>17</b>
<b>9. Maintenance Instructions</b>	<b>17</b>
<b>10. Proper Disposal</b>	<b>17</b>
<b>11. Appendix</b>	<b>18</b>
11.1 List of Abbreviations	18
11.2 Change Index, Operating Instructions	18
11.3 EU Declaration of Conformity	18

# 1. General

## 1.1 Information Concerning these Instructions

- These instructions apply to the product with ID code P1KY10x.
- They make it possible to use the product safely and efficiently.
- These instructions are an integral part of the product and must be kept on hand for the entire duration of its service life.
- Local accident prevention regulations and national work safety regulations must be complied with as well.
- The product is subject to further technical development, and thus the information contained in these operating instructions may also be subject to change. The current version can be found at [www.wenglor.com](http://www.wenglor.com) in the product's separate download area.



### NOTE!

The operating instructions must be read carefully before using the product and must be kept on hand for later reference.

## 1.2 Explanations of Symbols

- Safety precautions and warnings are emphasized by means of symbols and attention-getting words
- Safe use of the product is only possible if these safety precautions and warnings are adhered to

The safety precautions and warnings are laid out in accordance with the following principle:



---

### Attention-Getting Word! Type and Source of Danger!

Possible consequences in the event that the hazard is disregarded.

- Measures for averting the hazard.

---

The meanings of the attention-getting words, as well as the scope of the associated hazards, are listed below.



---

### DANGER!

This word indicates a hazard with a high degree of risk which, if not avoided, results in death or severe injury.

---



---

### WARNING!

This word indicates a hazard with a medium degree of risk which, if not avoided, may result in death or severe injury.

---



---

### CAUTION!

This word indicates a hazard with a low degree of risk which, if not avoided, may result in minor or moderate injury.

---



---

### ATTENTION!

This word draws attention to a potentially hazardous situation which, if not avoided, may result in property damage.

---



---

### NOTE!

A note draws attention to useful tips and suggestions, as well as information regarding efficient, error-free use.

---

### 1.3 Limitation of Liability

- The product has been developed in consideration of the current state-of-the-art and applicable standards and guidelines. Subject to change without notice.
- A valid declaration of conformity can be accessed at [www.wenglor.com](http://www.wenglor.com) in the product's separate download area.
- wenglor sensoric elektronische Geräte GmbH (hereinafter referred to as "wenglor") excludes all liability in the event of:
  - Non-compliance with the instructions
  - Use of the product for purposes other than those intended
  - Use by untrained personnel
  - Use of unapproved replacement parts
  - Unapproved modification of products
- These operating instructions do not include any guarantees from wenglor with regard to the described procedures or specific product characteristics.
- wenglor assumes no liability for printing errors or other inaccuracies contained in these operating instructions, unless wenglor was verifiably aware of such errors at the point in time at which the operating instructions were prepared.

### 1.4 Copyrights

- The contents of these instructions are protected by copyright law.
- All rights are reserved by wenglor.
- Commercial reproduction or any other commercial use of the provided content and information, in particular graphics and images, is not permitted without previous written consent from wenglor.

## 2. For Your Safety

### 2.1 Use for Intended Purpose

The product is based on the following functional principle:

#### High-Performance Distance Sensor

High-performance distance sensors which use the principle of transit time measurement determine the distance between the sensor and the object according to the principle of transit time measurement. These sensors have a large working range and are therefore able to detect objects over large distances.

#### This product can be used in the following industry sectors:

- Special machinery manufacturing
- Heavy machinery manufacturing
- Logistics
- Automotive industry
- Food industry
- Packaging industry
- Pharmaceuticals industry
- Plastics industry
- Woodworking industry
- Consumer goods industry
- Paper industry
- Electronics industry
- Glass industry
- Steel industry
- Aviation industry
- Chemicals industry
- Alternative energy
- Raw materials extraction

### 2.2 Use for Other than the Intended Purpose

- Not a safety component in accordance with 2006/42/EC (Machinery Directive)
- The product is not suitable for use in potentially explosive atmospheres.
- The product may only be used with accessories supplied or approved by wenglor, or combined with approved products. A list of approved accessories and combination products can be accessed at [www.wenglor.com](http://www.wenglor.com) on the product detail page.

---

#### **DANGER!**



#### **Risk of personal injury or property damage in case of use for other than the intended purpose!**

- Use for other than the intended purpose may lead to hazardous situations.
- Observe instructions regarding use for intended purpose.
-

## 2.3 Personnel Qualifications

- Suitable technical training is a prerequisite.
- In-house electronics training is required.
- Trained personnel must have uninterrupted access to the operating instructions.



### **DANGER!**

**Risk of personal injury or property damage in case of incorrect initial start-up and maintenance!**

Personal injury and damage to equipment may occur.

- Adequate training and qualification of personnel.
- 

## 2.4 Modification of Products



### **DANGER!**

**Risk of personal injury or property damage if the product is modified!**

Personal injury and damage to equipment may occur. Non-observance may result in loss of the CE marking and the guarantee may be rendered null and void.

- Modification of the product is impermissible.
- 

## 2.5 General Safety Precautions



### **NOTE!**

- These instructions are an integral part of the product and must be kept on hand for the entire duration of its service life.
- In the event of possible changes, the respectively current version of the operating instructions can be accessed at [www.wenglor.com](http://www.wenglor.com) in the product's download area.
- Read the operating instructions carefully before using the product.
- Protect the sensor against contamination and mechanical influences.

## 2.6 Laser/LED Warnings

The respective laser class or LED group is listed in the product's technical data.



### **Laser Class 1 (EN 60825-1)**

Invisible laser radiation.

Applicable standards and safety regulations must be observed.

---

## 2.7 Approvals and protection class



**RoHS**

### 3. Technical Data

Optical Data	
Working range	0...1500 mm
Setting range	50...1500 mm
Switching hysteresis	< 30 mm
Light source	Laser (infrared)
Wavelength	940 nm
Service life (ambient temp. = +25° C)	100000 h
Laser class (EN 60825-1)	1
Max. permissible ambient light	10000 Lux
Spot diameter	see Table 1
Electrical Data	
Supply power	10...30 V DC
IO-Link supply voltage	18...30 V DC
Current consumption (operating voltage = 24 V)	< 15 mA
Switching frequency	10 Hz
Response time	< 36 ms
Temperature drift	< 2,5 %
Temperature range	-30...50 °C
Number of switching outputs	2
Switching output voltage drop	< 2,5 V
Switching output switching current	100 mA
Short-circuit protection	yes
Reverse polarity protected	yes
Overload-proof	yes
Interface	IO-Link
IO-Link version	1.1
Protection class	III
Mechanical Data	
Setting method	Teach-in
Housing material	Plastic
Lens cover	PMMA
Degree of protection	IP67/IP68
Technical Safety Data	
MTTFd (EN ISO 13849-1)	2266,52 a

Order Number		P1KY1			
		01	03	02	04
Technical Data		M8×1; 4-pin		M12×1; 4-pin	
Connection		—		200 mm	
Cable length		7		2	
Suitable connection technology no.		×		×	
Output Function	PNP NO	×*		×*	
	NPN NO	×*		×*	

\* The normally open NPN output function makes reference to switching output 1 (O1, pin 4). Switching output 2 (O2, pin 2) has a normally open PNP output function.

### 3.1 Spot diameter

Working distance	350 mm	700 mm	1500 mm
Spot diameter	14 mm	25 mm	42 mm

Table 1

### 3.2 Switching Distance Deviation

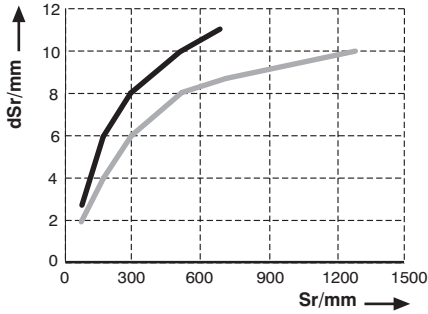

Typical characteristic curve based on Kodak white (90% remission)

Sr = switching distance  
dSr = change in switching distance

Black, 6 % remission  
Gray, 18 % remission

### 3.3 Accessory Products

wenglor can provide you with suitable connection technology for your product.

Suitable mounting technology no.	<b>400</b>
Suitable connection technology no.	<b>7 2</b>
	<b>S02</b>
PNP-NPN converter BG7V1P-N-2M	
IO-Link master	
wTeach2 software DNNF005	



### 3.4 Layout

P1KY101, P1KY103

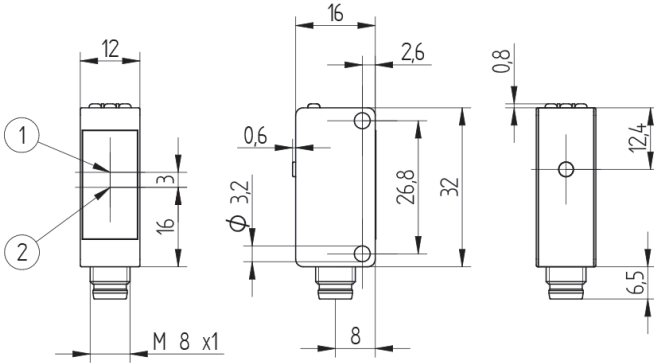

P1KY102, P1KY104

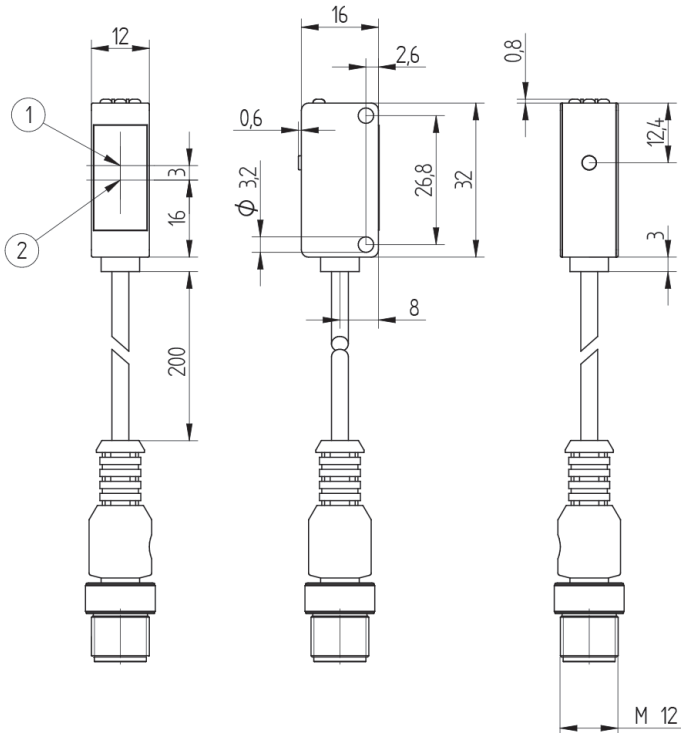

1 = receiver diode  
 2 = emitter diode  
 M3 screw = 0,5 Nm  
 Dimensions specified in mm (1 mm = 0.03937")

### 3.5 Control Panel

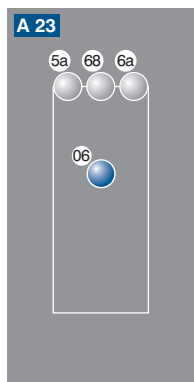

- 06 = teach-in key
- 5a = switching status display, A1
- 6a = switching status display, A2
- 68 = supply power indicator

### 3.6 Scope of Delivery

- Sensor
- Safety precautions
- Mounting-Set 01

## 4. Transport and Storage

### 4.1 Transport

Upon receipt of shipment, the goods must be inspected for damage in transit. In the case of damage, conditionally accept the package and notify the manufacturer of the damage. Then return the device, making reference to damage in transit.

### 4.2 Storage

**The following points must be taken into condition with regard to storage:**

- Do not store the product outdoors.
- Store the product in a dry, dust-free place.
- Protect the product against mechanical impacts.
- Protect the product against exposure to direct sunlight.



#### **ATTENTION!**

#### **Risk of property damage in case of improper storage!**

The product may be damaged.

- Storage instructions must be complied with.

## 5. Installation and Electrical Connection

### 5.1 Installation

- Protect the product from contamination during installation.
- Observe all applicable electrical and mechanical regulations, standards, and safety rules.
- Protect the product against mechanical influences.
- Make sure that the sensor is mounted in a mechanically secure fashion.
- Specified torque values must be complied with [see section “3. Technical Data”](#), page 7.



#### ATTENTION!

##### Risk of property damage in case of improper installation!

The product may be damaged.

- Installation instructions must be complied with.



#### CAUTION!

##### Risk of personal injury or property damage during installation!

Personal injury and damage to the product may occur.

- A safe installation environment must be assured.

### 5.2 Electrical Connection

Connect the sensor to supply voltage [see section “3. Technical Data”](#), page 7.

P1KY101, P1KY102

223

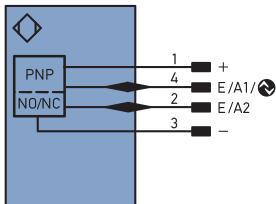

P1KY104

239

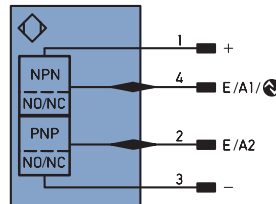

Legend

+	Supply Voltage +
-	Supply Voltage 0 V
~	Supply Voltage (AC Voltage)
A	Switching Output (NO)
Ā	Switching Output (NC)
V	Contamination/Error Output (NO)
∇	Contamination/Error Output (NC)
E	Input (analog or digital)
T	Teach Input
Z	Time Delay (activation)
S	Shielding
RxD	Interface Receive Path
TxD	Interface Send Path
RDY	Ready
GND	Ground
CL	Clock
E/A	Output/Input programmable
	<b>IO-Link</b>
PoE	Power over Ethernet
IN	Safety Input
oSSD	Safety Output
Signal	Signal Output
Bl_D +/-	Ethernet Gigabit bidirect. data line (A-D)
EN <sub>IR5422</sub>	Encoder 0-pulse 0-0̄ (TTL)

PT	Platinum measuring resistor
nc	not connected
U	Test Input
ū	Test Input inverted
W	Trigger Input
W-	Ground for the Trigger Input
O	Analog Output
O-	Ground for the Analog Output
BZ	Block Discharge
AWV	Valve Output
a	Valve Control Output +
b	Valve Control Output 0 V
SY	Synchronization
SY-	Ground for the Synchronization
E+	Receiver-Line
S+	Emitter-Line
±	Grounding
SnR	Switching Distance Reduction
Rx+/-	Ethernet Receive Path
Tx+/-	Ethernet Send Path
Bus	Interfaces-Bus A(+)/B(-)
La	Emitted Light disengageable
Mag	Magnet activation
RES	Input confirmation
EDM	Contactor Monitoring

EN <sub>IR5422</sub>	Encoder A/Ā (TTL)
EN <sub>IR5422</sub>	Encoder B/B̄ (TTL)
EN <sub>A</sub>	Encoder A
EN <sub>B</sub>	Encoder B
AMIN	Digital output MIN
AMAX	Digital output MAX
AOK	Digital output OK
SY <sub>In</sub>	Synchronization In
SY <sub>OUT</sub>	Synchronization OUT
OL <sub>T</sub>	Brightness output
M	Maintenance
rsv	reserved
Wire Colors according to DIN IEC 757	
BK	Black
BN	Brown
RD	Red
OG	Orange
YE	Yellow
GN	Green
BU	Blue
VT	Violet
GY	Grey
WH	White
PK	Pink
GNYE	Green/Yellow

**DANGER!**



**Risk of personal injury or property damage due to electric current!**

Voltage conducting parts may cause personal injury or damage to equipment.









- The electric device may only be connected by appropriately qualified personnel.

**5.3 Diagnostics**

Causes for Triggering the Contamination Warning (blinking LED):

Display LED	Diagnosis/Cause	Elimination
Continuous blinking at approx. 2.5 Hz	Contamination	Carefully clean the optic cover with a cloth.
	Aged emitter diode	Replace the sensor.
	Unreliable working range	<ul style="list-style-type: none"> <li>• Increase the sensor's switching distance.</li> <li>• Reduce distance between sensor and object.</li> </ul>
Continuous blinking at approx. 5 Hz	Short-circuit	Check electrical wiring and eliminate the short-circuit.
	Over-temperature	Disconnect the sensor from supply power and allow it to cool down.
	Hardware error	Replace the sensor.

## Contamination Warning Flowcharts

Transmit Time Sensor		no contamination		
				
Object	not detected	detected	not detected	
Switching Status Indicator	off <input type="radio"/>	on <input checked="" type="radio"/>	off <input type="radio"/>	
<b>beginning contamination</b>				
				
Object	not detected	detected	not detected	
Switching Status Indicator	off <input type="radio"/>	blinking <input type="radio"/>	off <input type="radio"/>	
<b>advanced contamination</b>				
				
Object	not detected	not detected	not detected	
Switching Status Indicator	off <input type="radio"/>	off <input type="radio"/>	off <input type="radio"/>	

### Required action in case of fault:

#### NOTE!

- Shut down the machine.
- Analyze and eliminate the cause of error with the help of the diagnostics information.
- If the error cannot be eliminated, please contact wenglor's support department.
- Do not operate in case of indeterminate malfunctioning.
- The machine must be shut down if the error cannot be unequivocally clarified or reliably eliminated.



#### DANGER!

#### Risk of personal injury or property damage in case of non-compliance!

- The system's safety function is disabled. Personal injury and damage to equipment.
- Required action as specified in case of fault.

## 6. Settings

The switching distance to the object can be taught in for both outputs by pressing the teach-in key on the sensor (foreground teach-in).

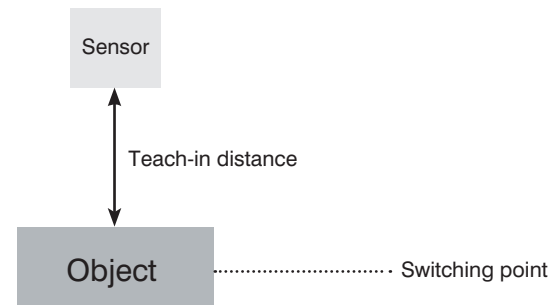

### Foreground Teach-In for Switching Output 1

1. Mount the sensor in accordance with the mounting instructions.
2. Position the object in front of the sensor.
3. Press and hold the teach-in key until switching status indicator LED A1 starts blinking.
4. Release the teach-in key after 2 seconds.
5. The distance is taught in and the LED at output 1 lights up in order to confirm successful teach-in.

### Foreground Teach-In for Switching Output 2

1. Mount the sensor in accordance with the mounting instructions.
2. Position the object in front of the sensor.
3. Press and hold the teach-in key until switching status indicator LED A2 starts blinking.
4. Release the teach-in key after 5 seconds.
5. The distance is taught in and the LED for output 2 lights up in order to confirm successful teach-in.



#### NOTE!

If teach-in is conducted without an object or if the object is too far from the sensor, switching distance is set to the end of the setting range.

## 7. Settings via IO-Link

Further settings can be entered to the sensor via the IO-Link interface.

### 7.1 Background Teach-In

In addition to foreground teach-in (default setting), there's also a background teach-in option for both outputs.

1. Align the sensor to the background.
2. Enter or teach in the switching point.
3. The sensor is switched as soon as an object is located between the background and the sensor.

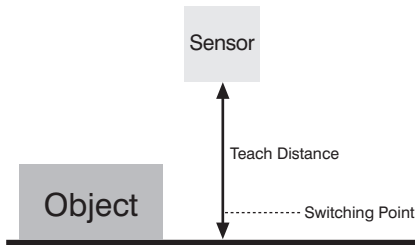

### 7.2 Window Teach-In

Additionally, there's also a window teach-in option for both outputs:

1. Enter or teach in the far switching point.
2. If necessary, adjust the window with the near and far switching points.
3. The sensor is switched when an object is located between the two switching points.

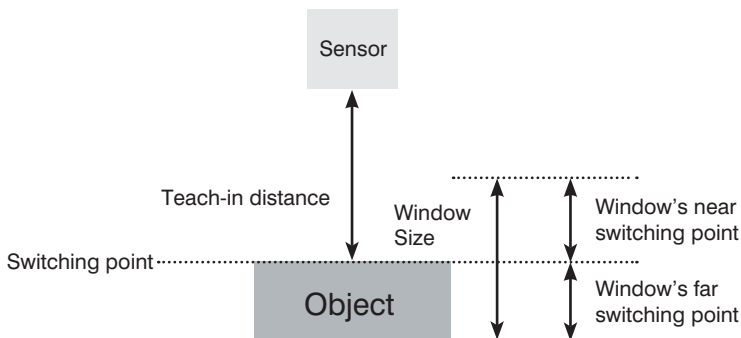

If the teach-in mode is selected, the switching point can be taught in by pressing the teach-in key.

### 7.3 Locking

If 18 to 30 V DC is continuously applied to the teach-in input, the teach-in key is locked and protected against inadvertent changes.

1. Change the A2 pin function to external teach-in.
2. Permanently connect pin A2 to voltage within a range of 18 to 30 V DC.
3. The sensor is protected against inadvertent changes caused by the teach-in key.

### 7.4 External Teach-In

Teach in output A1 via the teach-in input.

1. Set the A2 pin function to external teach-in.
2. Apply 24 V to pin A2 for at least 1 second, but for no more than 4 seconds.
3. As soon as voltage drops at the input, A1 is taught in.

### 7.5 Error Output

The error output is switched in the following cases:

- Signal from object too weak
- Incorrect installation
- The object is located outside of the working range.
- Short-circuit
- Over-temperature



## 8. IO-Link

Process and parameters data, as well as the IO-Link, can be found at [www.wenglor.com](http://www.wenglor.com) in the product's separate download area.

## 9. Maintenance Instructions



### NOTE!

- This wenglor sensor is maintenance-free.
- Cleaning and inspection of the plug connections at regular intervals are advisable.
- Do not clean the sensor with solvents or cleansers which could damage the product.
- The product must be protected against contamination during initial start-up.

## 10. Proper Disposal

wenglor sensoric GmbH does not accept the return of unusable or irreparable products. Respectively valid national waste disposal regulations apply to product disposal.

# 11. Appendix

## 11.1 List of Abbreviations

Abbreviation	Meaning
Tu	Ambient temperature
Ub	Supply voltage
IODD	IO Device Description
MTTFd	Mean Time to Dangerous Failure

## 11.2 Change Index, Operating Instructions

Version	Date	Description/Change
1.0.0	29.06.17	Initial version of the operating instructions
1.1.0	18.12.17	<a href="#">see section “7. Settings via IO-Link”, page 15</a>
1.2.0	15.01.19	New versions added, <a href="#">see section “3. Technical Data”, page 7</a>

## 11.3 EU Declaration of Conformity

The EU declaration of conformity can be found on our website at [www.wenglor.com](http://www.wenglor.com) in the product's download area.