

SS2-00VA000R3

Individual Safety Light Barrier Control Unit



Operating instructions

Table of contents

1 General	5
1.1 Function and Use for Intended Purpose	5
1.2 Features	5
1.3 Applications Examples	5
1.3.1 Single Barrier Protection	6
1.3.2 Multiple Barrier Protection	6
1.3.3 Muting Function	6
1.4 Brief Explanation	7
1.5 Explanation of Utilized Symbols	7
2 Important Notes Concerning Use	7
2.1 General Comments	7
2.2 Securing the Danger Zone	8
2.3 Safety Clearance per EN ISO 13855	8
2.3.1 Perpendicular Approach to the Safety Field	9
2.3.2 Parallel Approach to the Safety Field	10
2.4 Minimum Clearance to Reflective Surfaces	10
2.5 Mutual interference of the Light Barriers	11
3 Connection and Installation to the Machine	11
3.1 General	11
3.2 Notes Regarding Connector Cables	12
3.3 Terminal Assignments and LED Display	12
3.4 Connecting the light Barriers	13
3.4.1 Connecting One Light Barrier	14
3.4.2 Connecting Two Light Barriers	15
3.4.3 Connecting Three Light Barriers	16
3.4.4 Connecting Four Light Barriers	17
4 Inputs	18
4.1 Test Input	18
4.2 Acknowledgement Input	18
4.2.1 Selecting the Mode of Operation	18
4.2.2 Automatic Restart	18
4.2.3 Restart Inhibit	19
4.3 Contactor Monitoring	20

5 Outputs	22
5.1 Safety Outputs	22
5.2 Signal Control	22
5.3 Muting Signal Output	22
6 Muting	22
6.1 Basics	22
6.2 Connecting the Muting Sensors and the Muting Indicator	23
6.2.1 Muting Sensors	23
6.2.2 Muting Indicator	23
6.3 Selecting a Muting Duration	24
6.4 Mode of Operation	24
6.4.1 Muting Procedure	25
6.4.2 Muting Time Sequence	26
7 Override	26
7.1 Basics	26
7.2 Settings	26
7.2.1 Selecting the Mode of Operation	26
7.2.2 Override with Continuous Command	27
7.2.3 Override with Command Pulse	27
8 Functions and Operation	28
8.1 Use of One Channel	28
8.2 Use of Two Channel	28
8.3 Muting Modul	28
9 Diagnosis Information	29
10 Inspection Instructions	30
10.1 Inspection Prior to Initial Start-Up	30
10.2 Daily Inspection and Maintenance	30
10.3 Yearly Inspection and Maintenance	30
11 Environmentally Sound Disposal	31
12 Dimensional Drawings	31
13 Accessories and Order Designation	32

14 Technical Data	32
14.1 Safety Light Barriers	32
14.2 Individual Light Barrier Control Unit	33
15 Checklist	35
16 Certification	35
17 EC Declaration of Conformity	36
17.1 Declaration of conformity for Individual Safety Light Barrier Control Units SS2	36
17.2 Declaration of conformity for Safety Through Beam Sensor SL2	37

Due to the fact that they describe the operation of a safety device, these operating instructions are of a binding nature.

1 General

The SS2-00VA000R3 Individual Light Barrier Control Unit is part of a design-approved, contactless safety device in accordance with EN 61496-1 for electro-sensitive protective equipment (ESPE).

It's a type 2 safety device in per EN 61496-1.

The ESPE consists of an Individual Light Barrier Control Unit to which as many as four sensors can be connected.

Use of the Individual Light Barrier Control Unit is only permitted with wenglor SL2-00 Light Barriers (see section 13 for order designations). Safety category 2 and Performance Level c is otherwise not assured.

For this reason, use with SL2-00 Light Barriers is described in these operating instructions.

- It is absolutely essential to observe all of the instructions included herein in order to assure safe use of the ESPE.
- Non-observance of the instructions included herein may place the operator of the system into great danger.

1.1 Function and Use for Intended Purpose

The Individual Light Barrier Control Unit monitors the safety field between the light barriers. If the safety field is penetrated by an object, a switching command is triggered. This switching command may prevent initialization of a hazardous machine motion, or may stop an action which has already been started.

Use of the Individual Light Barrier Control Unit in combination with SL2-00NE000H2/SL2-00NS000H2 oder SL2-00TE000H1/SL2-00TS000H2 Light Barriers is only permissible if:

- The hazardous motion can be stopped electrically by the safety output of the Individual Light Barrier Control Unit
- The use of a type 2 safety device is permissible in accordance with the risk analysis

After completion of every new installation or change of the configuration, the entire safety system must be tested for correct functioning (i.e. Individual Light Barrier Control Unit, Safety Light Barriers and the machine). In particular if the restart inhibit mode was originally activated, it must be assured that the unit is once again configured for this mode of operation. In order to check the safety field a testing stick (see section 8) can be used.

1.2 Features

- Safety device per EN 61496-1, type 2
- TÜV certification
- Long working range with SL2-00TS000H2 and SL2-00TE000H1 (transmitter/receiver)
- Easy to use
- Floating safety relay outputs (normally open contacts)
- Either restart inhibit or automatic restart
- Monitoring of external safety relays
- For connection of up to 4 light barriers
- One PNP output for displaying system status
- Periodic self-testing of the connected safety light barriers (every 20 seconds)
- Integrated muting function
- One muting enable input
- One PNP output for connecting a muting indicator
- Muting duration of either 30 seconds or unlimited
- Integrated override function

1.3 Applications Examples

A risk analysis is decisive regarding use of the Individual Light Barrier Control Unit.

Use is conceivable with the following types of machines:

- Palletizers
- Textile machinery
- Transfer and assembly lines
- Automatic insertion equipment
- Packaging machines
- Rotary indexing machines
- Woodworking machines
- Warehouse technology

1.3.1 Single Barrier Protection

Use for securing robots

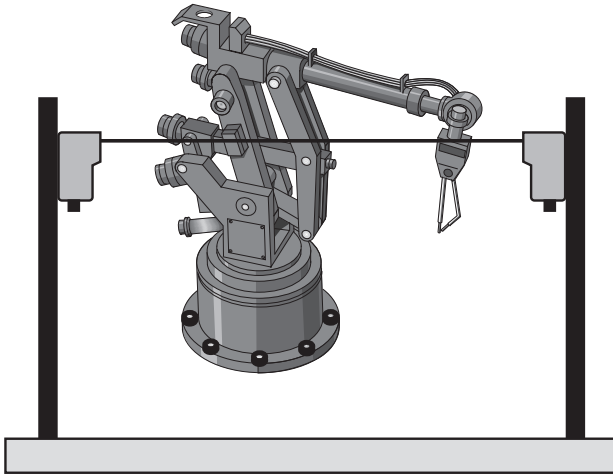

1.3.2 Multiple Barrier Protection

Use for access monitoring

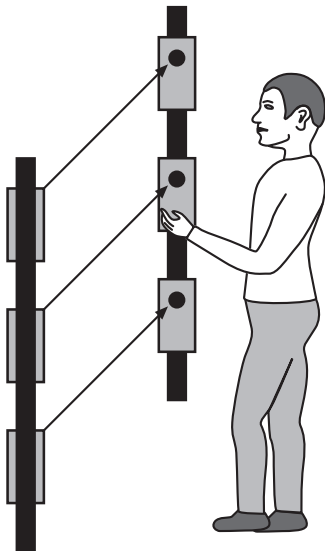

1.3.3 Muting Function

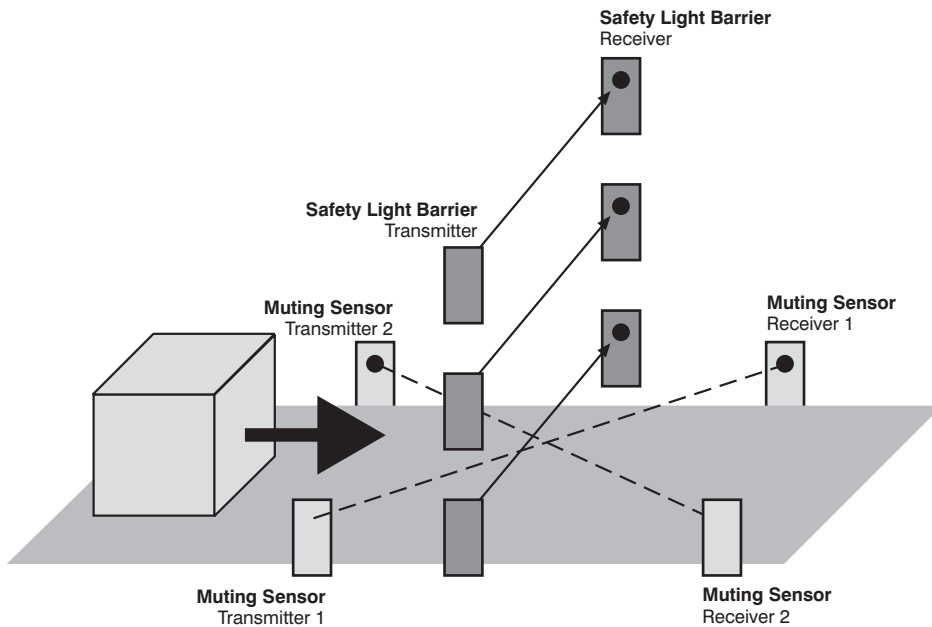

1.4 Brief Explanation

Contactor Monitoring

An operating mode for which switching performance of the contacts at an external relay is dynamically monitored. The contacts must close fully within a specified period of time.

Muting Mode

Objects can be fed through the safety field without switching the safety output in this operating mode.

OSSD (Output Signal Switching Device)

The output of the contactless safety device which is connected to the machine controls. The safety output is deactivated when the safety field is interrupted.

Override

This function enables to switch the outputs ON if the protection zone is interrupted. If there is for example after an error during the Muting Operation Mode still material within the protection zone, this material can be removed with the help of the Override function.

Restart Inhibit

A function which prevents a machine from starting up automatically after it has been switched on. The machine can only be enabled by activating an acknowledgement key.

Safety Operating Mode

In this operating mode, the switching outputs are disabled when the safety field is penetrated. The switching outputs are automatically enabled after penetration of the safety field is ended.

Signal Output

The signal output is used to connect a watchdog for the floating blanking, auto floating blanking and reduced resolution function types.

1.5 Explanation of Utilized Symbols



Makes reference to a measure for the prevention of a concrete danger.



Illustrates suggestions and instructions, which make use of the controller easier.

2 Important Notes Concerning Use

2.1 General Comments

The use of electro-sensitive protective equipment (ESPE) is regulated by official directives. National and international regulations apply to the safe utilization of ESPE, in particular:

- EN standards
- Accident prevention regulations

Contactless safety devices may only be used at power operated machinery whose controls can be electrically influenced such that hazardous motion can be stopped immediately during all operating phases.

A risk analysis in accordance with ISO 14121 must be conducted before use, in order to determine whether or not the use of a safety device Performance Level c per EN ISO 13849-1 is permissible.

If other light beams occur in an application (e.g. use of infrared controls, radiation of welding processes, stroboscope lights) additional measures could be necessary to assure that the ESPE doesn't fail dangerously.



Powerful fluorescent lamps must not be pointed directly towards the receiver's lens. The receiver might otherwise fail in a hazardous manner.



Testing must be performed by an expert prior to initial start-up of electro-sensitive protective equipment. Testing must establish flawless interaction of the electro-sensitive protective equipment together with the controls of the power operated machinery, and correct installation in accordance with these safety precautions.



2.2 Securing the Danger Zone

The danger zone must be secured by means of the light barriers alone, or by means of the light barriers in combination with additional mechanical safety devices. Reaching around, over and/or under the safety field must be prevented in any case. It must be impossible to approach the point of danger without passing through the light barriers. The safety field is located between the beam emission of the sender and the beam entry at the receiver. The beam diameter is smaller than 30 mm.

The Light Barriers are only allowed to be used to secure access according to EN ISO 13855. The use for finger and hand protection is not allowed.

2.3 Safety Clearance per EN ISO 13855

Safety clearance S is calculated with the following formula in accordance with EN ISO 13855: $S = K \times T + C$

A gripping speed of 1,6 meters per second is assumed.

Example:

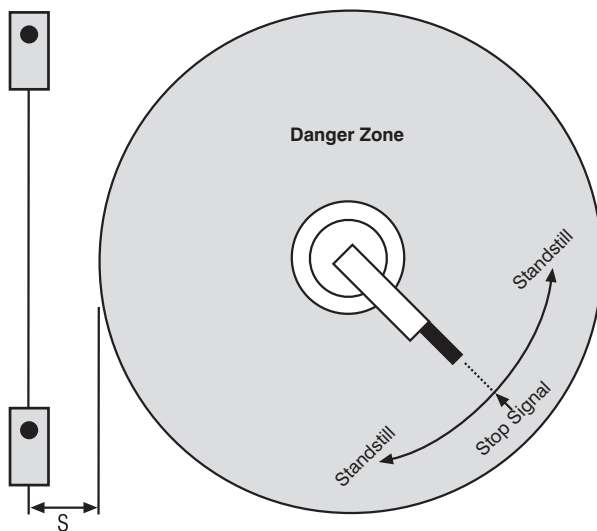

S = Minimum safety clearance in mm, measured from the danger zone to the point of detection, to the line of detection or to the safety field.

K = Approach speed constant in mm per sec. = 1600 mm per sec.

T = Total response time (t1 + t2) in seconds

t1 = Response time of the Individual Light Barrier Control Unit in seconds

t2 = Machine or process over-travel time in seconds

C = Additional clearance in mm (margin), which is based upon penetration into the danger zone before the safety device is triggered

Obstruction of the safety field during hazardous motion results in immediate shutdown. The distance between the safety field and the point of danger must be large enough to assure that the point of danger cannot be reached until hazardous motion has come to a standstill. This safety clearance depends upon total over-travel time, as well as the person's maximum gripping or walking speed.

Total over-travel time is the sum of maximum response time of the ESPE and maximum over-travel time of the hazardous motion. Machine over-travel time must be determined by means of repeated measurement prior to initial start-up, and each time the machine is retooled or set up.

In order to secure the danger zones, the safety heights set forth in EN ISO 13855 are determined by means of a risk analysis in accordance with EN ISO 13849-1.

2.3.1 Perpendicular Approach to the Safety Field

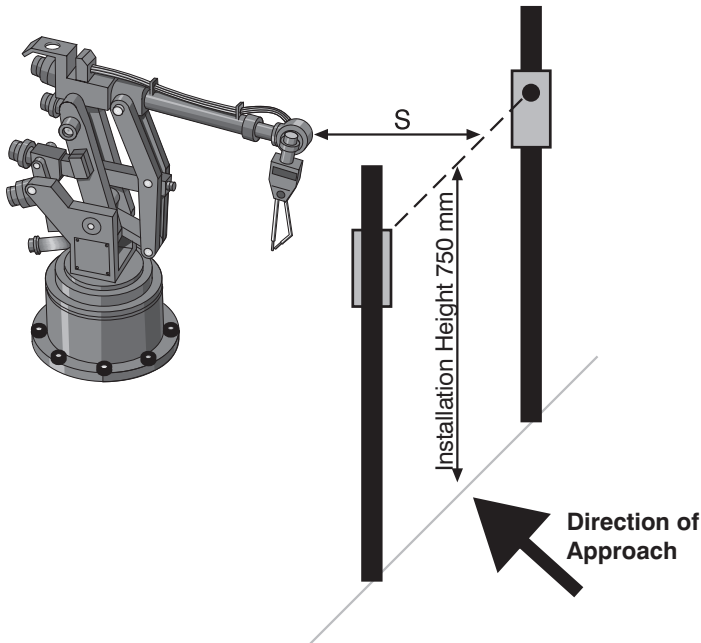

A minimum installation height of 750 mm from the reference level is required for the use of a light barrier

C = Margin for penetration into the danger zone before the safety device is tripped (never < 0) = 1200 mm

K = 1600 mm per second

$$S = K \times (t_1 + t_2) + C(1200 \text{ mm})$$

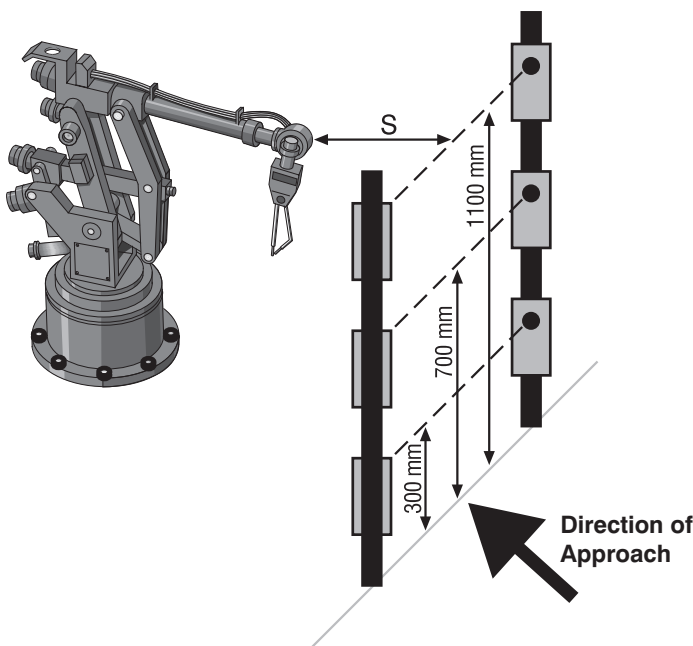

If more than one light barrier is used, the table included below applies.

C = Margin for penetration into the danger zone before the safety device is tripped (never < 0) = 850 mm

K = 1600 mm per second

$$S = K \times (t_1 + t_2) + C(850 \text{ mm})$$

The number of utilized light barriers is based upon EN ISO 13855 in consideration of the relevant level C standard.



Number of Light Barriers	Installation Height in mm Above the Reference Level			
	Barrier 1	Barrier 2	Barrier 3	Barrier 4
1	750			
2	400	900		
3	300	700	1100	
4	300	600	900	1200

2.3.2 Parallel Approach to the Safety Field

If this safety concept is used, the height of the safety field (H) may not be any greater than 1000 mm. If H is greater than 300 mm (or 200 mm for non-industrial applications, e.g. if children are present), one runs the risk of inadvertent, undetected access from underneath the safety field. This must be taken into consideration during risk analysis.



H = Height of the safety field above the reference level

C = Margin for penetration into the danger zone before the safety device is tripped (never < 850) = 1200 mm - 0,4×H

K = 1600 mm per second

S = K×(t1+t2)+C(1200 mm - 0,4×H)

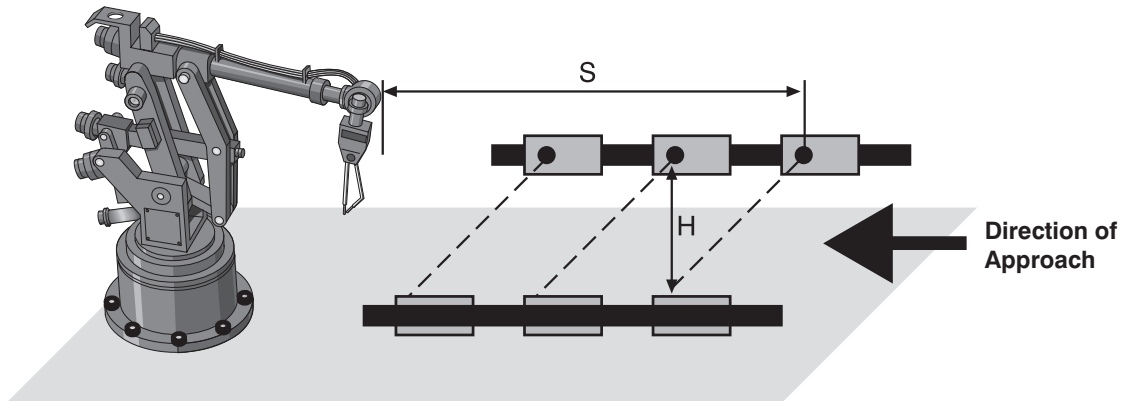

S = Minimum safety clearance

H = Height of the safety field

2.4 Minimum Clearance to Reflective Surfaces

If reflective surfaces are located within the aperture angle between the transmitter and the receiver, reflection may result which could cause an obstruction to go undetected. For this reason, a minimum clearance (m) between reflective objects and the optical axis must be maintained.

Beam angles are taken from the IEC 61496-2 standard. They represent worst case values. Actual values are lower.

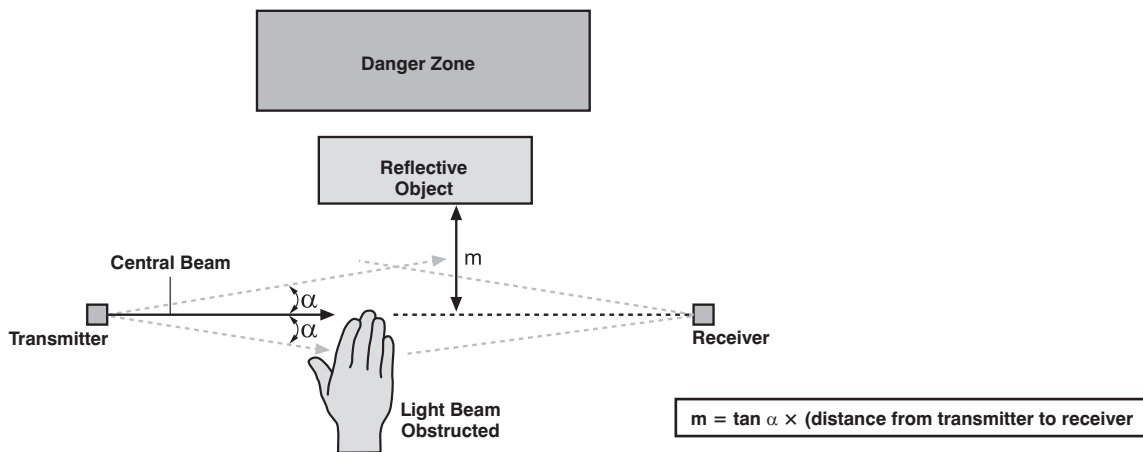

α = Opening Angle of Emitter and Receiver Optic

$\alpha = \pm 5^\circ$

Max. distance m in m

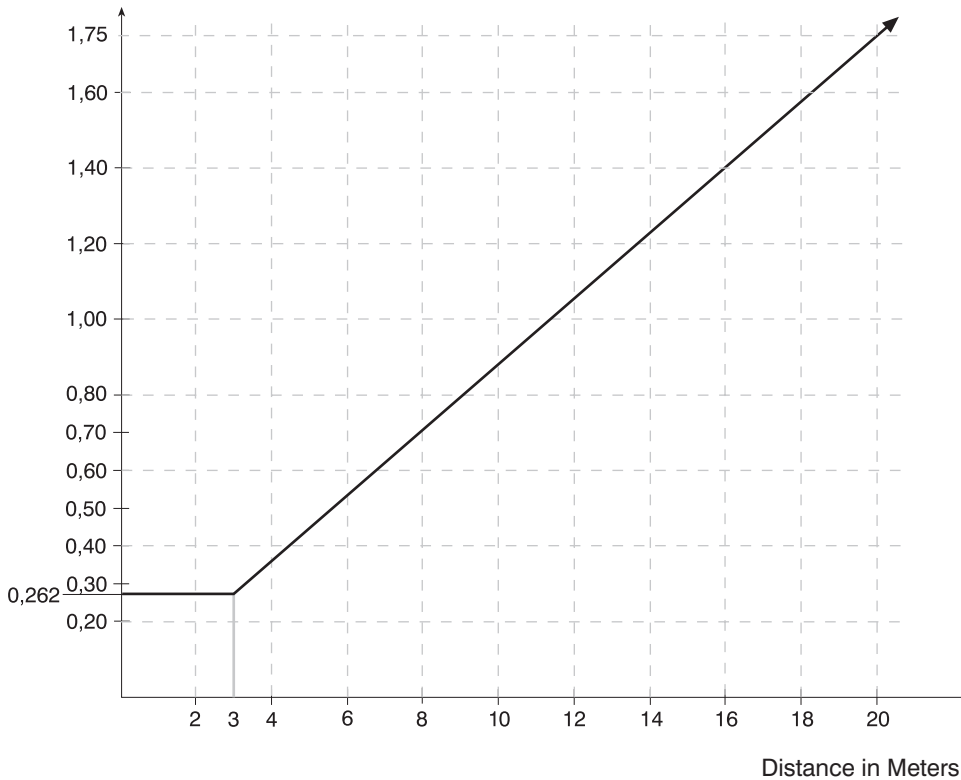

2.5 Mutual interference of the Light Barriers

In order to inhibit a mutual interference of the Light Barriers, to following points have to be adhered to:

- Within the opening angle of the receiver (transmitter) should only be the transmitter (receiver).
- In case of Multiple Barrier Protection an arrangement of the Light Barriers according to the following picture has to be preferred:

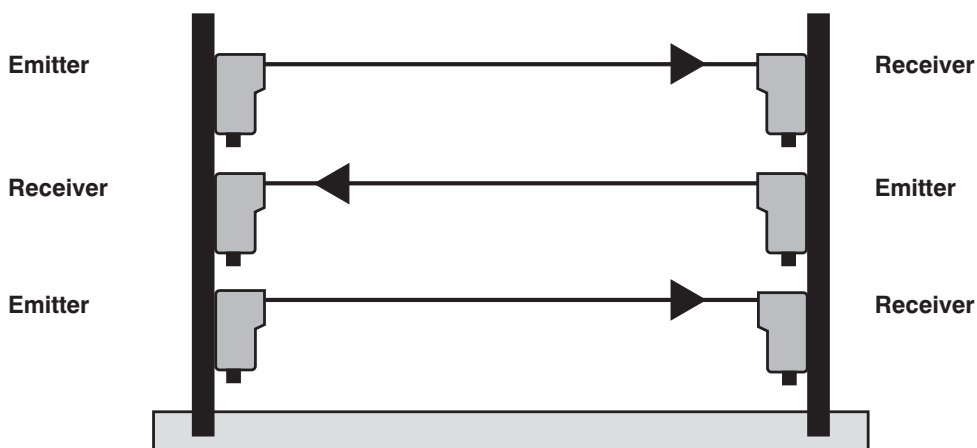

3 Connection and Installation to the Machine

3.1 General

The Individual Light Barrier Control Unit must be integrated into the system such that at least IP 54 protection is assured (e.g. installation to a control cabinet).

After the light barriers have been mechanically mounted (see operating instructions for SL2-00), the SS2-00VA000R3 control unit is linked to the machine's controller.



The OSSD outputs must be connected to the machine's safety circuit such that safety category 2 is still complied with. The safety precautions for the respective machine, and for connection to the machine's controller, must also be observed.

If several control units are mounted next to each other, a minimum clearance of 2 cm must be maintained between the units in order to avoid overheating.

The control unit must be provided with 24 V DC \pm 20% supply power.

External power supply must comply with EN 60204-1.



It is absolutely essential that terminals 17 and 18 are not short-circuited during installation.

Additional measures for the prevention of electrostatic discharge should be implemented during installation, troubleshooting and adjustment.

It is advisable to furnish the connector cables with wire end ferrules before installing the light barriers.

3.2 Notes Regarding Connector Cables

- Cables with a cross-section of greater than 1 square mm must be used for connections between safety light barriers and the control with lengths of more than 50 meters.
- Supply power for the control unit should be isolated from other electrical equipment (electrical motors, inverters, frequency variators), as well as any other sources of interference.
- The connector cables between the control unit and the sensors, connector cables to the test command generator and to the feedback contacts connected to terminal 20 must be laid separately from power conducting cables.

3.3 Terminal Assignments and LED Display

1	2	3	13		15	
4	5	6	16	17	18	
M1			CH1			
M2			CH2/ Failure			
MUT			OSSD/ DIAG			
7	8	9	19	20	21	
10	11	12	22	23	24	

Terminal	Designation	Input/ Output	Further Information
1	Muting input 1	I	p. 23, section 6.2
2	Muting input 2	I	p. 23, section 6.2
3	24 V DC	–	–
4	Muting duration 1	I	p. 24, section 6.3
5	Muting duration 2	I	p. 24, section 6.3
6	Restart inhibit	I	p. 19, section 4.2.3
7	Override 1	I	p. 26, section 7
8	Override 2	I	p. 26, section 7
9	S1 test	O	–
10	Muting signal	O	p. 22, section 5.3
11	Muting enable	I	–
12	OSSD B contact 1	O	–
13	0 V	–	–
14	PE (ground)	–	–
15	Acknowledgement input	I	p. 18, section 4.2
16	contact	I	p. 18, section 4.1
17	S1 contact	I	–
18	S2 contact	I	–
19	S2 test	O	–
20	Contacting monitoring	I	p. 20, section 4.3
21	Signal control	O	–
22	OSSD B contact 2	O	–
23	OSSD A contact 1	O	–
24	OSSD A contact 2	O	–

LED	Color	Status	Operating State
M1	Yellow	Off	Muting sensor 1 unobstructed
		On	Muting sensor 1 obstructed
M2	Yellow	Off	Muting sensor 2 unobstructed
		On	Muting sensor 2 obstructed
MUT	Yellow	Off	Normal operation
		On	Muting active
		Blinking	<ul style="list-style-type: none"> • Override request • Muting failure (only with CH/Failure on) *
CH1	Green	On	Channel 1 unobstructed
		Off	Channel 1 obstructed
CH2 Failure	Green, Red	Red	Failure detected *
		Green	Channel 2 unobstructed
		Off	Channel 2 unobstructed or unused
OSSD DIAG	Green, Red, Yellow	Red	Output relay open
		Red blinking	The number of pulses indicates the type of failure (only when CH2/Failure is on) *
		Green	Output relay closed
		Yellow	Channel unobstructed – relay open (only with restart inhibit)

* See error codes on page 29 in section 9

3.4 Connecting the light Barriers

The following wiring diagrams demonstrate connection of the light barriers to the control unit using the automatic restart setting, and without contact monitoring.



It must be assured that a muting indicator is always connected, in order to assure correct functioning of the controller.

3.4.1 Connecting One Light Barrier

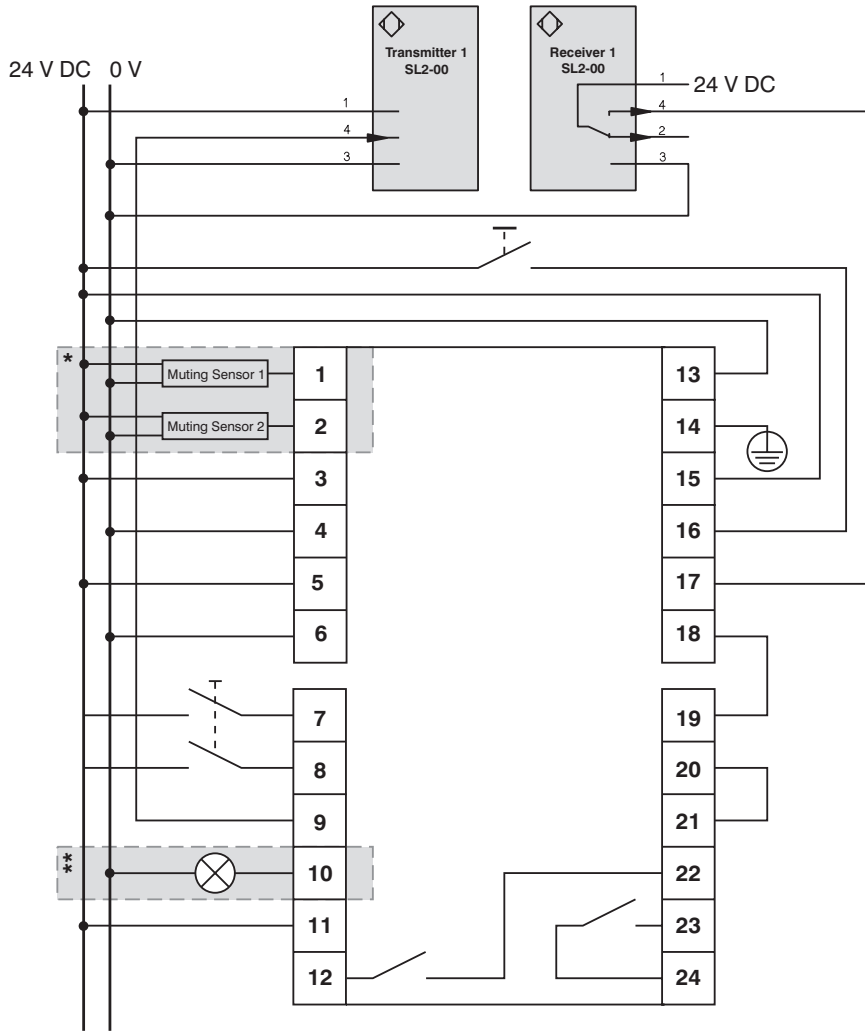

* See page 23 in section 6.2.1

** See page 23 in section 6.2.2

Terminal	Designation	Input/ Output	Further Information
1	Muting input 1	I	p. 23, section 6.2
2	Muting input 2	I	p. 23, section 6.2
3	24 V DC	-	-
4	Muting duration 1	I	p. 24, section 6.3
5	Muting duration 2	I	p. 24, section 6.3
6	Restart inhibit	I	p. 19, section 4.2.3
7	Override 1	I	p. 26, section 7
8	Override 2	I	p. 26, section 7
9	S1 test	O	-
10	Muting signal	O	p. 22, section 5.3
11	Muting enable	I	-
12	OSSD B contact 1	O	-
13	0 V	-	-
14	PE (ground)	-	-
15	Acknowledgement input	I	p. 18, section 4.2
16	contact	I	p. 18, section 4.1
17	S1 contact	I	-
18	S2 contact	I	-
19	S2 test	O	-
20	Contacting monitoring	I	p. 20, section 4.3
21	Signal control	O	-
22	OSSD B contact 2	O	-
23	OSSD A contact 1	O	-
24	OSSD A contact 2	O	-

3.4.2 Connecting Two Light Barriers

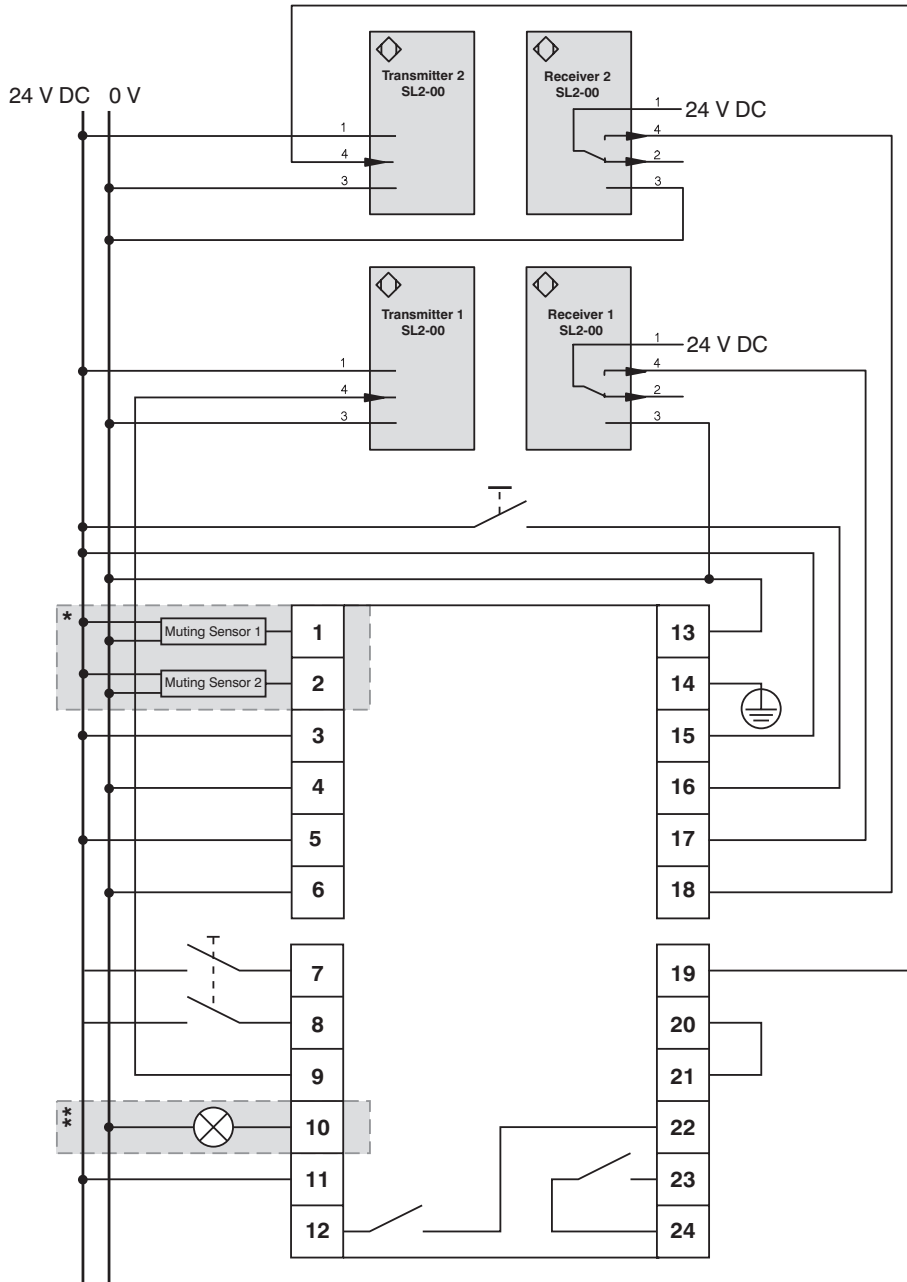

* See page 23 in section 6.2.1

** See page 23 in section 6.2.2.

Terminal	Designation	Input/Output	Further Information	Terminal	Designation	Input/Output	Further Information
1	Muting input 1	I	p. 23, section 6.2	13	0 V	-	-
2	Muting input 2	I	p. 23, section 6.2	14	PE (ground)	-	-
3	24 V DC	-	-	15	Acknowledgement input	I	p. 18, section 4.2
4	Muting duration 1	I	p. 24, section 6.3	16	Test input	I	p. 18, section 4.1
5	Muting duration 2	I	p. 24, section 6.3	17	S1 NO contact	I	-
6	Restart inhibit	I	p. 19, section 4.2.3	18	S2 NO contact	I	-
7	Override 1	I	p. 26, section 7	19	S2 test	O	-
8	Override 2	I	p. 26, section 7	20	Contact monitoring	I	p. 20, section 4.3
9	S1 test	O	-	21	Signal control	O	-
10	Muting signal	O	p. 22, section 5.3	22	OSSD B contact 2	O	-
11	Muting enable	I	-	23	OSSD A contact 1	O	-
12	OSSD B contact 1	O	-	24	OSSD A contact 2	O	-

3.4.3 Connecting Three Light Barriers

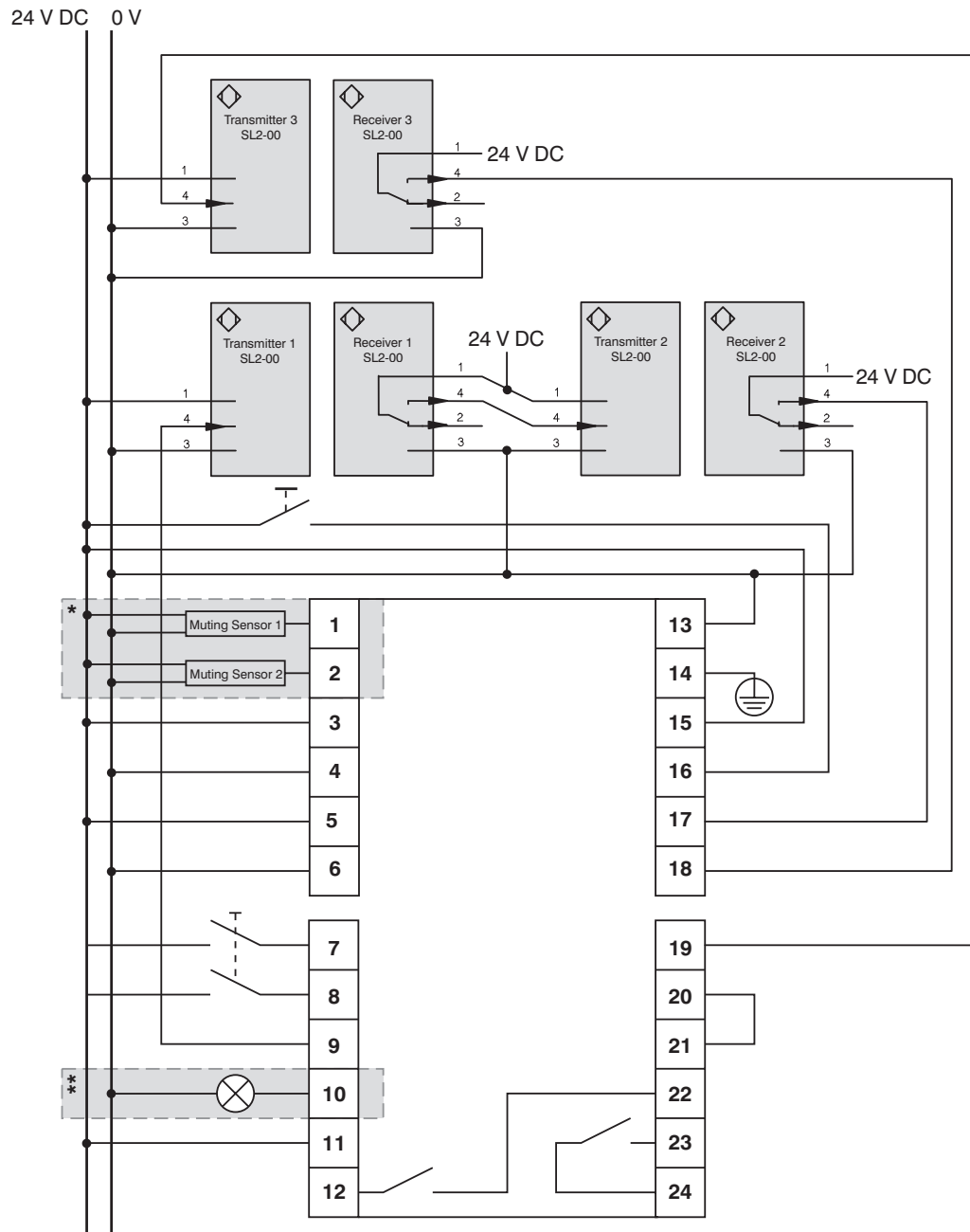

* See page 23 in section 6.2.1

** See page 23 in section 6.2.2

Terminal	Designation	Input/Output	Further Information	Terminal	Designation	Input/Output	Further Information
1	Muting input 1	I	p. 23, section 6.2	13	0 V	-	-
2	Muting input 2	I	p. 23, section 6.2	14	PE (ground)	-	-
3	24 V DC	-	-	15	Acknowledgement input	I	p. 18, section 4.2
4	Muting duration 1	I	p. 24, section 6.3	16	Test input	I	p. 18, section 4.1
5	Muting duration 2	I	p. 24, section 6.3	17	S1 NO contact	I	-
6	Restart inhibit	I	p. 19, section 4.2.3	18	S2 NO contact	I	-
7	Override 1	I	p. 26, section 7	19	S2 test	O	-
8	Override 2	I	p. 26, section 7	20	Contact monitoring	I	p. 20, section 4.3
9	S1 test	O	-	21	Signal control	O	-
10	Muting signal	O	p. 22, section 5.3	22	OSSD B contact 2	O	-
11	Muting enable	I	-	23	OSSD A contact 1	O	-
12	OSSD B contact 1	O	-	24	OSSD A contact 2	O	-

3.4.4 Connecting Four Light Barriers

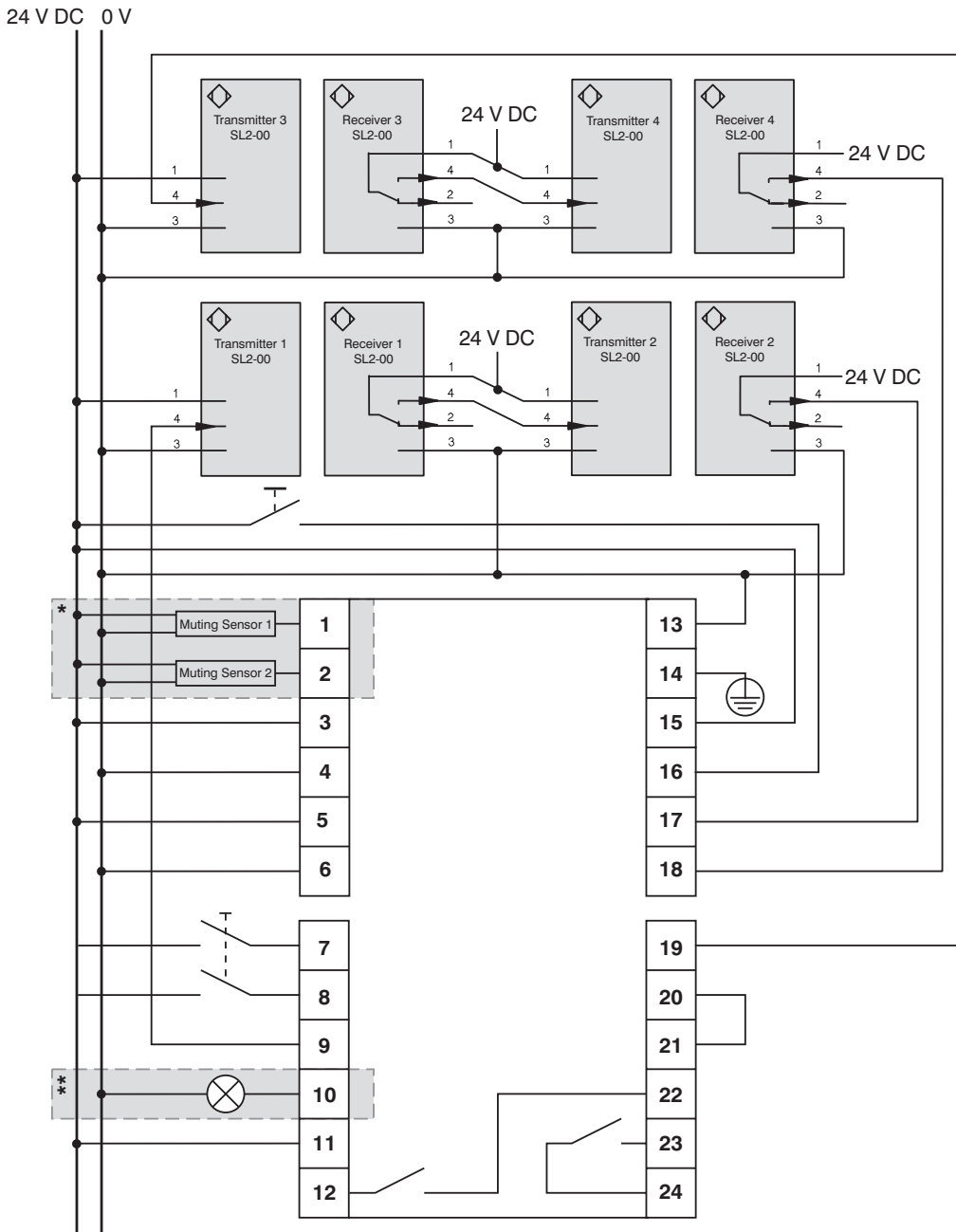

* See page 23 in section 6.2.1

** See page 23 in section 6.2.2.

Terminal	Designation	Input/Output	Further Information	Terminal	Designation	Input/Output	Further Information
1	Muting input 1	I	p. 23, section 6.2	13	0 V	-	-
2	Muting input 2	I	p. 23, section 6.2	14	PE (ground)	-	-
3	24 V DC	-	-	15	Acknowledgement input	I	p. 18, section 4.2
4	Muting duration 1	I	p. 24, section 6.3	16	Test input	I	p. 18, section 4.1
5	Muting duration 2	I	p. 24, section 6.3	17	S1 NO contact	I	-
6	Restart inhibit	I	p. 19, section 4.2.3	18	S2 NO contact	I	-
7	Override 1	I	p. 26, section 7	19	S2 test	O	-
8	Override 2	I	p. 26, section 7	20	Contact monitoring	I	p. 20, section 4.3
9	S1 test	O	-	21	Signal control	O	-
10	Muting signal	O	p. 22, section 5.3	22	OSSD B contact 2	O	-
11	Muting enable	I	-	23	OSSD A contact 1	O	-
12	OSSD B contact 1	O	-	24	OSSD A contact 2	O	-

4 Inputs

4.1 Test Input

A self-test is started at the control unit by applying 24 V DC to the test input (terminal 16). When the control unit's safety inputs are activated, the control unit indicates that testing is being executed by shutting down the transmitters at the connected safety light barriers, and thus simulating penetration of the protected area. The operator must then check the effectiveness of the shut down. The transmitters are shut down for as long as 24 V DC is applied to the input.

The externally triggered test has no significance with regard to testing the control unit, because it is self-testing.

The test pulse has a minimum duration of 40 ms. Test frequency is based upon the risk analysis (safety regulations).

4.2 Acknowledgement Input

The control unit can be setup with either restart inhibit or automatic restart.

The use of restart inhibit (start and restart disabled) is required if the safety device is used to secure a passageway to the danger zone, and if it is possible for a person to be present in the danger zone without being detected after traversing the passageway.

4.2.1 Selecting the Mode of Operation

The following table depicts configuration of the operating modes.

Selecting the Mode of Operation		
Terminal 6	Terminal 15	Mode of Operation
0 V not connected	24 V DC	Automatic restart
24 V DC	0 V not connected	Restart inhibit
0 V not connected	0 V not connected	Impermissible operation
24 V DC	24 V DC	

4.2.2 Automatic Restart

In this operating mode, the control unit's outputs correspond to the status of the light barriers:

- If the safety zone is unobstructed (light barrier outputs active), the relay outputs are activated.
- If the safety zone is obstructed (light barrier outputs inactive), the relay outputs are deactivated.

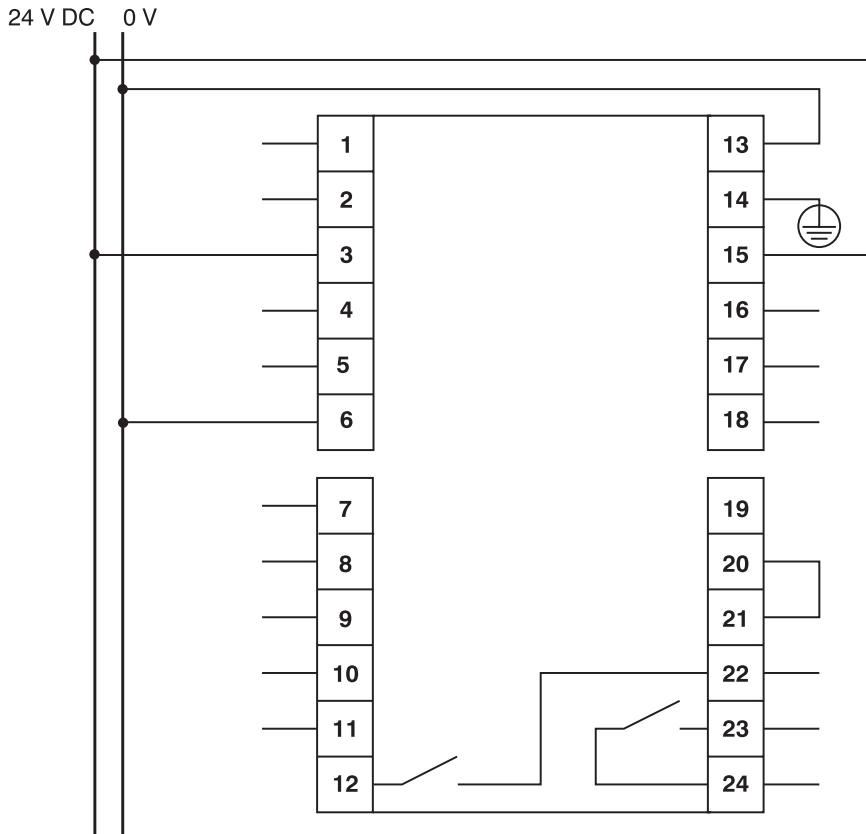

Terminal	Designation	Input/Output	Further Information	Terminal	Designation	Input/Output	Further Information
1	Muting input 1	I	p. 23, section 6.2	13	0 V	-	-
2	Muting input 2	I	p. 23, section 6.2	14	PE (ground)	-	-
3	24 V DC	-	-	15	Acknowledgement input	I	p. 18, section 4.2
4	Muting duration 1	I	p. 24, section 6.3	16	Test input	I	p. 18, section 4.1
5	Muting duration 2	I	p. 24, section 6.3	17	S1 NO contact	I	-
6	Restart inhibit	I	p. 19, section 4.2	18	S2 NO contact	I	-

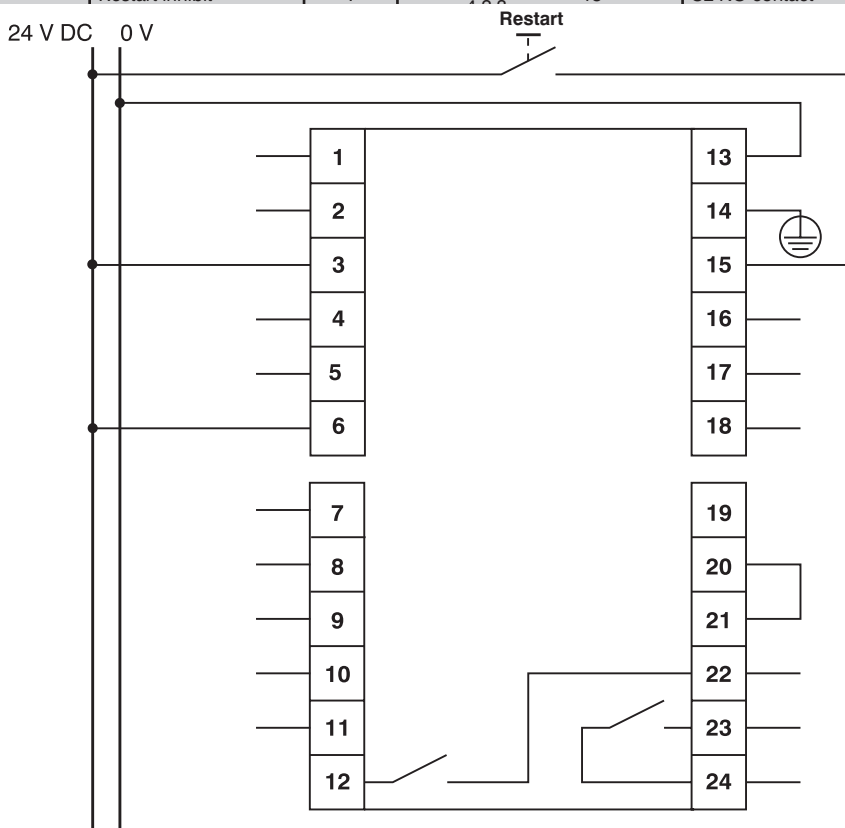

-
/
/

-
-

d
a

Terminal	Designation	Input/Output	Further Information	Terminal	Designation	Input/Output	Further Information
1	Muting input 1	I	p. 23, section 6.2	13	0 V	–	–
2	Muting input 2	I	p. 23, section 6.2	14	PE (ground)	–	–
3	24 V DC	–	–	15	Acknowledgement input	I	p. 18, section 4.2
4	Muting duration 1	I	p. 24, section 6.3	16	Test input	I	p. 18, section 4.1
5	Muting duration 2	I	p. 24, section 6.3	17	S1 NO contact	I	–
6	Restart inhibit	I	p. 19, section 4.2.3	18	S2 NO contact	I	–
7	Override 1	I	p. 26, section 7	19	S2 test	O	–
8	Override 2	I	p. 26, section 7	20	Contact monitoring	I	p. 20, section 4.3
9	S1 test	O	–	21	Signal control	O	–
10	Muting signal	O	p. 22, section 5.3	22	OSSD B contact 2	O	–
11	Muting enable	I	–	23	OSSD A contact 1	O	–
12	OSSD B contact 1	O	–	24	OSSD A contact 2	O	–

4.3 Contactor Monitoring

Contacting monitoring is used to determine whether or not external contactors or auxiliary contact elements function properly. External contactors may only be connected if they are equipped with positively driven, normally closed contacts. The contactors are monitored statically and dynamically for correct timing performance of the contacts. Switching time may not exceed 300 ms. 24 V DC is returned to the input via an available NC contact at the external contactor.

Input for Contactor Monitoring

If external relays or K1 and K2 auxiliary contact elements with positively driven contacts are used, 24 V DC must be connected in series to the contactor monitoring input (terminal 20) via control contacts K1-1 and K2-1 (NC, block B in the graphic). Monitoring for correct switching of K1 and K2 is delayed 300 ms after the effective command.

If no K1 and K2 auxiliary contact elements are used, terminals 20 (contact monitoring) and 21 (signal monitoring) must be connected to each other.

- Control contacts K1-1 and K2-1 (terminal 20, block B) must be capable of switching a current of 20 mA and a voltage of 24 V DC.
- In order to extend the service life of internal relays A and B, suitable interference suppressors should be used which are connected to the ends of the windings at L1 and L2 (block A).
- The external contactors L1 and L2 must be provided with an appropriate supply power (CSP).

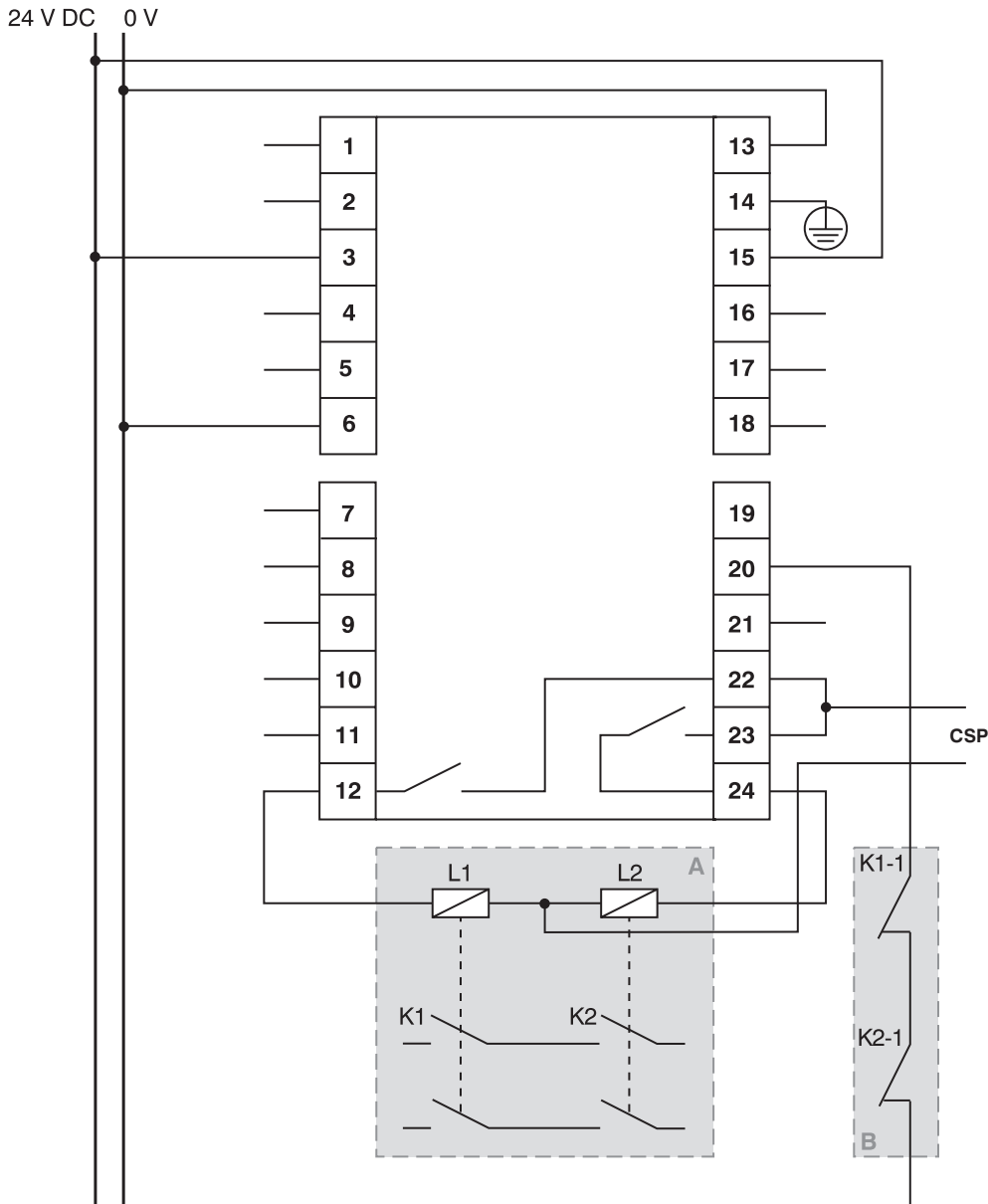

CSP = Contactor Supply Power

Terminal	Designation	Input/Output	Further Information	Terminal	Designation	Input/Output	Further Information
1	Muting input 1	I	p. 23, section 6.2	13	0 V	–	–
2	Muting input 2	I	p. 23, section 6.2	14	PE (ground)	–	–
3	24 V DC	–	–	15	Acknowledgement input	I	p. 18, section 4.2
4	Muting duration 1	I	p. 24, section 6.3	16	Test input	I	p. 18, section 4.1
5	Muting duration 2	I	p. 24, section 6.3	17	S1 NO contact	I	–
6	Restart inhibit	I	p. 19, section 4.2.3	18	S2 NO contact	I	–
7	Override 1	I	p. 26, section 7	19	S2 test	O	–
8	Override 2	I	p. 26, section 7	20	Contactor monitoring	I	p. 20, section 4.3
9	S1 test	O	–	21	Signal control	O	–
10	Muting signal	O	p. 22, section 5.3	22	OSSD B contact 2	O	–
11	Muting enable	I	–	23	OSSD A contact 1	O	–
12	OSSD B contact 1	O	–	24	OSSD A contact 2	O	–

5 Outputs

5.1 Safety Outputs

The control unit makes use of two safety relays with positively driven contacts (OSSD relays) as an output circuit. In order to avoid damage or premature ageing, each contact must be protected with a 4 A slow-blow fuse. Loads must comply with the technical data (see section 14).

5.2 Signal Control

The signal control output reads out the switching status of the safety relay in the control unit:

- The output is open when the relay outputs are open.
- 24 V DC is applied to the output when the relay outputs are closed.

The output is designed to control an optical indicator lamp. As an alternative, a PLC can also be connected which processes the signal. This output is a PNP output.

5.3 Muting Signal Output

The muting signal output is used to control a muting indicator:

- 0 V is applied to the output when muting is deactivated.
- 24 V DC is applied to the output when muting is active.

The muting indicator is an optical indicator lamp (e.g. wenglor's SM0-00CA000C1). This output is also a PNP output.

6 Muting

6.1 Basics

Muting causes temporary interruption of the protective function of the safety light barrier. This makes it possible to move certain objects through the safety field without deactivating the output, for example if material has to be fed through the safety field to the process, in which case no reaction from the safety device is required. At the same time, undesired reaching or walking into the danger zone must be detected by the muting controls.

Muting is only possible after connecting two muting sensors (in general light barriers) to the muting inputs and a muting indicator (e.g. wenglor's SM0-00CA000C1) to the muting signal output.

The muting sensors serve as a receiving system, which decides whether the muting function will be activated or deactivated. Monitoring of the dangerous passageway is only interrupted if the muting sensors are activated in the correct time sequence. The muting indicator indicates that the safety function has been temporarily deactivated. Connection of the muting sensors and the muting indicator is explained in section 6.2.

Due to the fact that muting impairs the safety function, correct use of this function is extremely important. Carefully examine your own risk analysis in order to make sure that the muting function is compatible with your application. Additional measures (e.g. coverings) must be implemented in order to assure that the bypassed safety field cannot be circumvented.

The following points must be observed in order to assure that the safety function is maintained during muting operation (see also EN 61496).

- The muting indicator indicates an increased risk of danger during muting.
The muting indicator is required for muting mode operation and must be visible to the operator.
- If no muting indicator has been connected, the OSSD safety relays remain in the off state.
-  Arrangement of the muting sensors depends upon the application, and necessitates a risk analysis.

- The muting sensors must be arranged such that they cannot be bypassed inadvertently by a person.
- The loaded pallet or the material must block access to the danger zone during muting.
- After the pallet or the material has passed through the safety field, muting must be stopped and the Individual Light Barrier Control Unit must once again be rendered fully effective.
- The geometric arrangement must be selected such that it is impossible for a person to pass through, either in front of or behind the object (possible use of additional, mechanical barriers)

- The sensors should detect the material only, and not the means of conveyance (e.g. pallet).

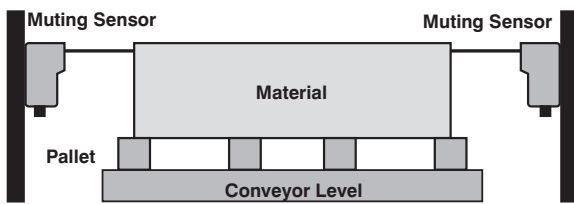

The sensors should detect the load, and not the pallet.

- The material must be detected throughout the entire muting zone, i.e. the sensors' output signals must remain unchanged. This requirement must above all be adhered to when the material is uneven, is shifted when it enters the muting zone or if its height changes.

6.2 Connecting the Muting Sensors and the Muting Indicator

6.2.1 Muting Sensors

The muting sensors must be integrated into the system as shown in the following diagram.

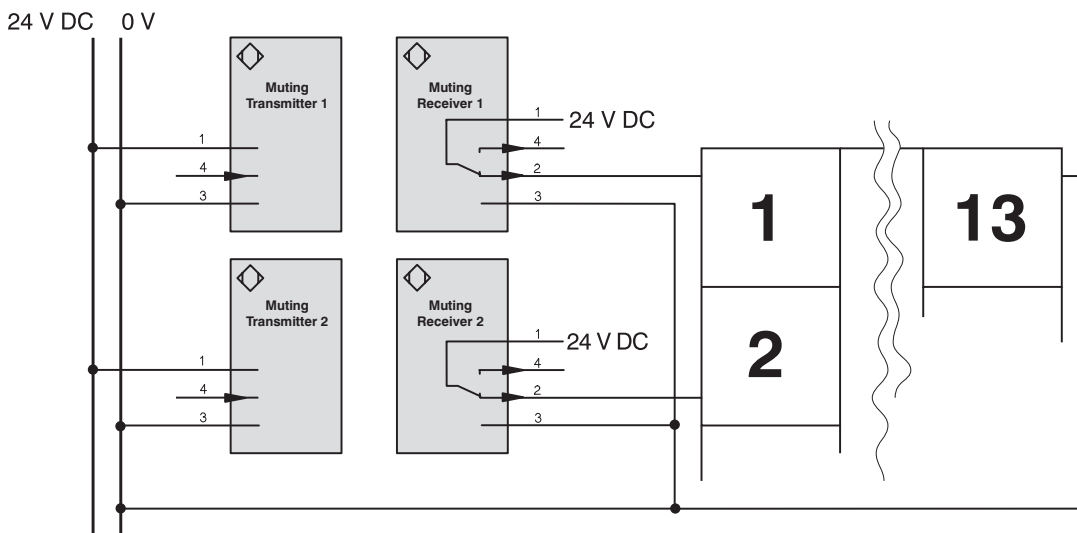

6.2.2 Muting Indicator

The muting indicator must be integrated into the system as shown in the following diagram.

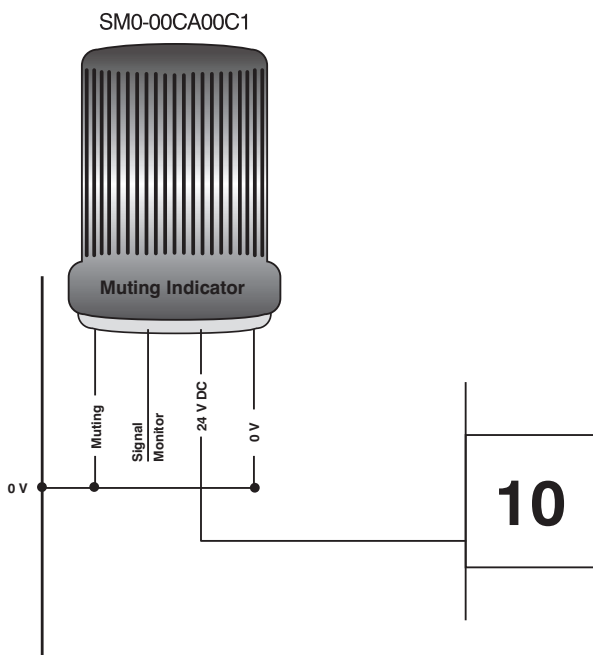

6.3 Selecting a Muting Duration

The following table depicts the configuration of muting duration.

Selecting a Muting Duration		
Terminal 4	Terminal 5	Time Limiting
0 V not connected	24 V DC	30 seconds
24 V DC	0 V not connected	Unlimited
0 V not connected	0 V not connected	Impermissible conditions
24 V DC	24 V DC	



Don't forget that muting involves a temporary interruption of the safety function. This means that muting duration must always be limited. If a limit of 30 seconds is too short for a particular machine sequence, configuration without any querying for an exceeded time limit can be selected (unlimited). In this case, additional precautions must be implemented in order to be able to detect continuous muting due to simultaneous errors, or constantly obstructed muting sensors, for example monitoring of the signals generated by the system itself for pallet conveyor systems, in order to determine whether or not and how long a pallet is located in the passageway.

6.4 Mode of Operation

Muting is only possible when the entire muting system is connected. This includes both muting sensors and the muting indicator. Any wenglor light barrier with an antivalent PNP output (the output must read out 24 V as long as the light beam is unobstructed) can be used as a muting sensor.

Preferred wenglor sensor: SN 2003 + EN 200 PA3. The muting indicator (SM0-00CA000C1) and the muting sensors must be connected as shown in the wiring diagram in section 6.2.

At the beginning, the output is activated and the safety light barrier has been successfully tested. Both muting sensors are unobstructed.

Muting is activated when the following events occur simultaneously:

1. The 24 V DC muting enable signal is applied to terminal 11. This has no effect on deactivation of the function itself. If muting is not required, 0 V is applied to terminal 11.
2. Both muting sensors are obstructed within 4 seconds.

Muting now begins, the protective function of the safety field is deactivated and the muting indicator lights up.

Muting is ended when one of the two following events is detected:

1. One of the muting sensors is no longer obstructed.
2. The muting time limit expires. This is only the case if muting time has been limited to 30 seconds. The object which caused the time limit to be exceeded must now be removed from the passageway. This is made possible, for example, by the override function.

6.4.1 Muting Procedure

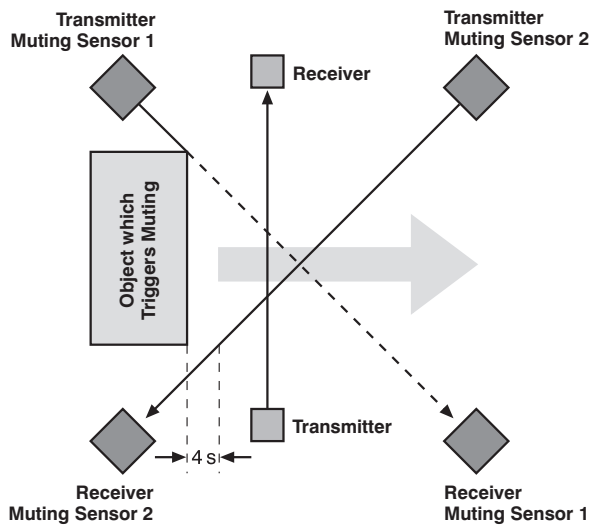

The muting sensors must be arranged such that both of their beams are obstructed by the object before it enters the safety field.

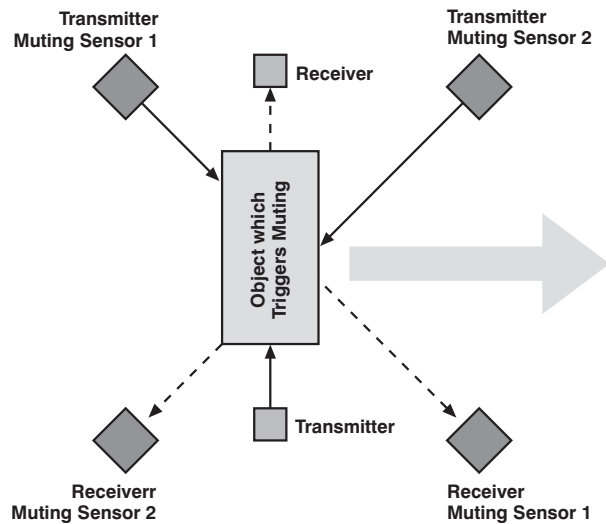

After muting has been activated as a result of obstruction of both muting sensors within a period of 4 seconds, the protective function of the safety field is deactivated.

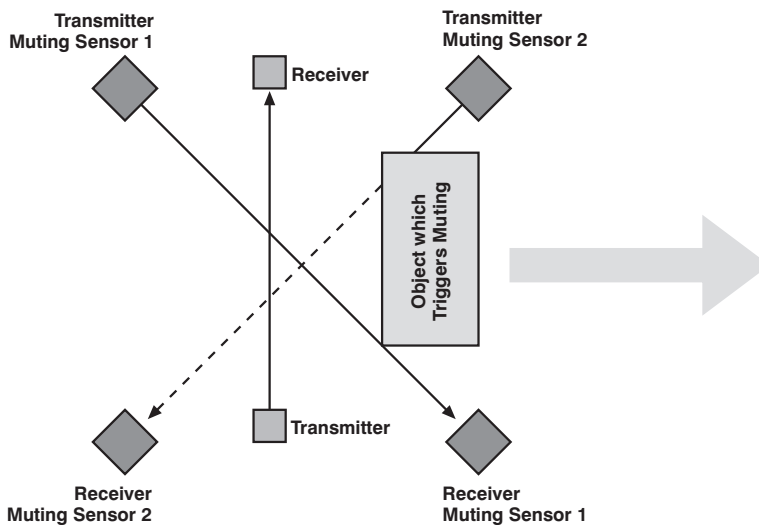

As soon as one of the muting sensors is no longer obstructed, muting is ended and the safety field is reactivated.

6.4.2 Muting Time Sequence

Muting duration 30 sec., without exceeding the Time Limit

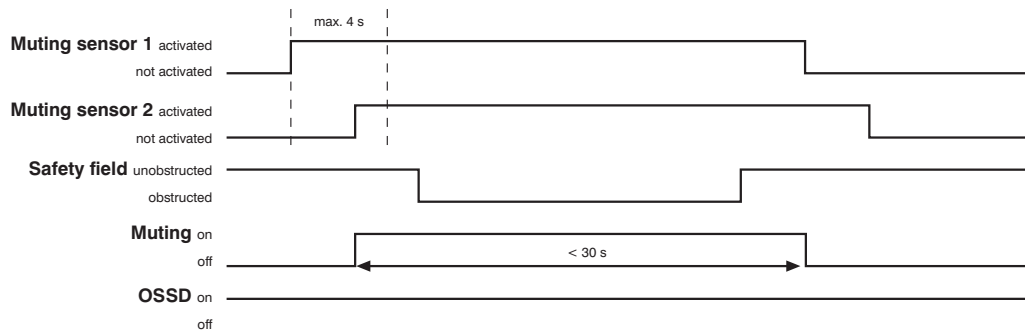

Muting duration 30 sec., with exceeding the Time Limit

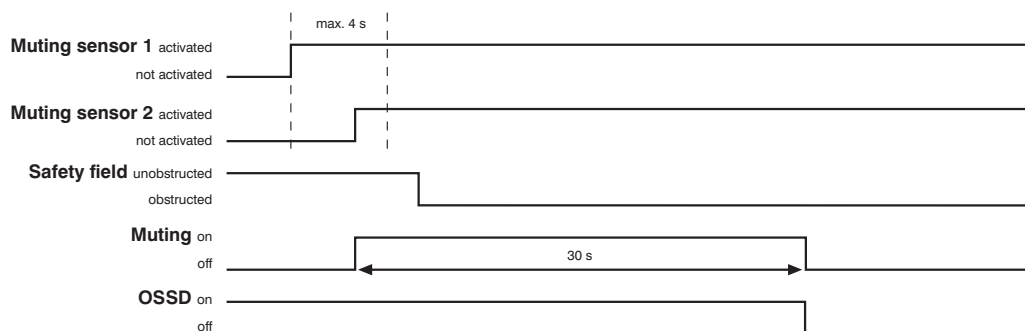

7 Override

7.1 Basics

Override is required in order to switch the safety outputs ON when the safety field is obstructed. This is necessary, for example, after an incorrect muting activation sequence when material is still located in the dangerous passageway.

In this case, the OSSD outputs are set to OFF because the safety light barrier and/or at least one muting sensor is obstructed. The override display blinks in this case (see section 8.3).

The override mode sets the OSSD outputs to ON, and makes it possible to remove the material which is blocking the passageway. The muting indicator is activated as well.

This procedure must be carried out under the supervision of an operator who is outside of the danger zone, and has a plain view of it.

7.2 Settings

Two types of override are available to the user, which he can select in advance:

- 1 Override with continuous command
- 2 Override with command puls

7.2.1 Selecting the Mode of Operation

The following table depicts configuration of the operating modes..

Selecting the Operating Mode		
Terminal 7	Terminal 8	Mode of Operation
0 V not connected	0 V not connected	Override with continuous command
0 V not connected	24 V DC	Override with command pulse

During setup it must be assured that terminals 7 and 8 are not short-circuited.

7.2.2 Override with Continuous Command

Override is activated when 24 V DC is applied to terminals 7 and 8 at the control module within a period of 400 ms, for example with a 2-pole key switch with spring return.

Terminal 7	Terminal 8	Mode of Operation
0 V not connected	0 V not connected	Normal operation
24 V DC	24 V DC	Continuous command

This operation sets the OSSD outputs to ON, and makes it possible to remove the material which is blocking the passageway by means of operator control. The muting indicator is activated as well. Override remains active for a maximum period of 15 minutes. It is ended when:

- the continuous override command is cancelled by applying 0 V to terminals 7 and 8
- or
- all safety light barriers and muting sensors are unobstructed
- or
- 15 minutes have elapsed since initial activation

The last two points are reset after a complete muting sequence has been completed correctly.

7.2.3 Override with Command Pulse

Override is activated by reversing the normal conditions for terminals 7 and 8 at the control unit within a period of 400 ms, for example with the help of a pushbutton. When override is activated, this condition no longer exists.

Terminal 7	Terminal 8	Mode of Operation
0 V not connected	24 V DC	Normal operation
24 V DC	0 V not connected	Command pulse

Override remains active for a maximum period of 15 minutes. Afterwards a new activation is possible. It is ended when:

- 15 minutes have elapsed since the first activation
- or
- all safety light barriers and muting sensors are unobstructed
- or
- a command pulse has been generated more than 30 times.

8 Functions and Operation

8.1 Use of One Channel

LED			Meaning
CH1 green	CH2/Failure red/green	OSSD/DIAG red/green/yellow	
On	Red	Red	Start-up test
Off	Off	Red	Channel obstructed, outputs off
On	Off	Yellow	Channel unobstructed, outputs off, unit is waiting for restart
Off	Off	Green	Channel unobstructed, outputs on
Indicates the status of the channel	Off	Yellow blinking (twice per second)	System test

8.2 Use of Two Channel

LED			Meaning
CH1 green	CH2/Failure red/green	OSSD/DIAG red/green/yellow	
On	Red	Red	Start-up test
Off	Off	Red	Channel obstructed, outputs off
Off	Green	Red	
On	Off	Red	
On	Green	Yellow	Channel unobstructed, outputs off, unit is waiting for restart
On	Green	Green	Channel unobstructed, outputs on
Indicates the status of channel 1	Indicates the status of channel 2	Yellow blinking (twice per second)	System test

8.3 Muting Modul





LED			Meaning
M1 yellow	M2 yellow	MUT yellow	
On	On	On	Start-up test
Off	Off	Off	Both muting sensors unobstructed
On	Off	Off	Muting sensor 1 obstructed
Off	On	Off	Muting sensor 2 obstructed
On	On	On	Muting active
Indicates the status of muting sensor 1	Indicates the status of muting sensor 2	Blinking	Override request



9 Diagnosis Information

If errors occur during use of the Individual Light Barrier Control Unit, the safety output is deactivated and the error LED blinks. Errors are eliminated in accordance with the following errors table.

If an error occurs continuously, a trained specialist must be consulted.

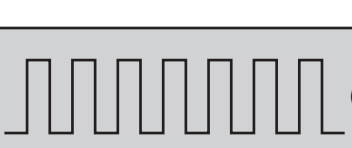
If necessary, the Individual Light Barrier Control Unit must be returned for repair. Repairs may not be carried out by unauthorized persons.

LED			Meaning → Remedy
CH1 green	CH2/Failure red/green	OSSD/DIAG red/green/yellow	
Off	Red	 (2 pulses, red)	Internal error → Please contact the support department
Off	Red	 (3 pulses, red)	Error at internal relays → Please contact the support department
Off	Red	 (4 pulses, red)	Error at the external contactor → Inspect wiring
Off	Red	 (5 pulses, red)	Incorrect initial configuration → Check configuration of start-up disabling, contactor monitoring, muting duration, the muting indicator and override
Off	Red	 (6 pulses, red)	Configuration changed without restart. Switch the unit off and back on again to eliminate the problem. → Switch the unit off and back on again
Off	Red	 (7 pulses, red)	Possible overload or incorrect connection of signal monitoring → Check the contact monitoring circuit

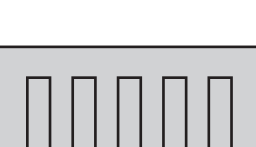
LED			Meaning → Remedy
M1 yellow	M2 yellow	MUT yellow	
Off	Off	 (2 pulses)	Muting lamp connected incorrectly, lamp is missing or overloaded → Make sure that the lamp is present and connected
Off	Off	 (3 pulses)	Incorrect configuration of muting duration → Check configuration and reenter
Off	Off	 (4 pulses)	Incorrect override configuration at start-up → Check configuration of start-up disabling, contactor monitoring, muting duration, the muting indicator and override
Indicates the status of muting sensor 1	Indicates the status of muting sensor 2	 (5 pulses)	Unstable muting sensor → Inspect wiring



Do not operate in case of indeterminate malfunctioning.

The machine must be shut down if the error cannot be unequivocally clarified or reliably eliminated.

10 Inspection Instructions

The inspections described below serve to confirm compliance with specified safety requirements set forth in national/international regulations, in particular the safety requirements included in the machinery directive and the directive concerning safety and health requirements for the use of work equipment (EC conformity).

The inspections also serve to detect influences which effect the device's protective action, as well as any other unusual ambient influences.

10.1 Inspection Prior to Initial Start-Up

Inspection prior to initial start-up, conducted by trained personnel, is intended to assure that the electro-sensitive protective equipment (ESPE), as well as any other safety components, have been correctly selected in accordance with local ordinances, and that they provide the required protection when used for their intended purpose.

- Inspection of ESPE in accordance with local ordinances. Inspection for correct attachment of the safety device, correct electrical connection to the controller and effectiveness in all of the machine's operating modes.
- The same inspection requirements apply if the machine in question has been shut down for a lengthy period of time and after significant modifications or repairs, if these may influence safety in any way.
- Observe regulations regarding the training of operating personnel by experts before operators begin work. The company which operates the machine is responsible for training.

The safety function of the ESPE must be tested by penetrating the safety field with a suitable test rod with a diameter of 30 mm prior to each time the machine is started up, and each time the machine has been retooled or set up. The test object must be moved through the light beam. Each beam must be tested separately, and the OSSD/DIAG LED display must switch from green to red. If restart inhibit is active, the green display must go out for each respective obstructed channel (CH1/CH2).

The check list for initial operation (Chapter 13) helps executing the testing.

10.2 Daily Inspection and Maintenance

Regular inspections must be completed in accordance with local ordinances. They serve the purpose of detecting changes to (e.g. over-travel time), or manipulation of the machine and the safety devices.

National regulations, e.g. ZH 1/597, ZH 1/281, and machine-specific directives apply to the execution of daily inspections.

Daily inspections must be conducted by a person who has been authorized and engaged to do so by the company which operates the machine when work begins, and whenever a new shift is started.

- The effectiveness of the ESPE must be tested with supply power to the ESPE switched on, and supply power to the hazardous motion of the machine switched off.
- Testing is conducted with the help of a suitable test rod, and never by manually reaching into the danger zone.
- The test object must be moved through the light beam. Each beam must be tested separately, and the OSSD/DIAG LED display must switch from green to red.

10.3 Yearly Inspection and Maintenance

The effectivity of the Safety equipment has to be assured within the requested periods, minimum once a year. The testing has to be executed by specialized personnel.

- Minimum safety clearances and total response time should be checked. The inspector should also examine the primary controls at the machine to assure that they function correctly, and that the safety output is switched in a failsafe fashion.
- Furthermore, it must be determined whether or not it is only possible for persons and individual limbs to enter the danger zone exclusively by passing through the safety field between the emitter and the receiver.
- The results of inspections and testing must be documented, and the user must keep a copy of such records on file.
- The ESPE, as well as all utilized accessories (connector cables, mounting kit), must be inspected for wear, damage, excessive contamination and correct mounting.

If any impairment of the device's safety function is detected during daily testing or during operation, all work at the respective machine must be immediately stopped.

11 Environmentally Sound Disposal

SL2-00 Light Barriers and the SS2-00VA000R3 Individual Light Barrier Control Unit neither contain nor emit any ecologically harmful substances. They consume minimum amounts of energy and resources.

Disposal:

Devices which are no longer usable must be disposed of in accordance with all respectively valid, national waste disposal regulations.

The housings of the individual Safety Light Barriers and the Individual Light Barrier Control Unit are made of plastic, and can be disposed of at plastics disposal centers.

All electronic components must be disposed of as special waste.

wenglor sensoric gmbh does not accept the return of unusable or irreparable devices.

12 Dimensional Drawings

SS2-00VA000R3 Individual Light Barrier Control Unit

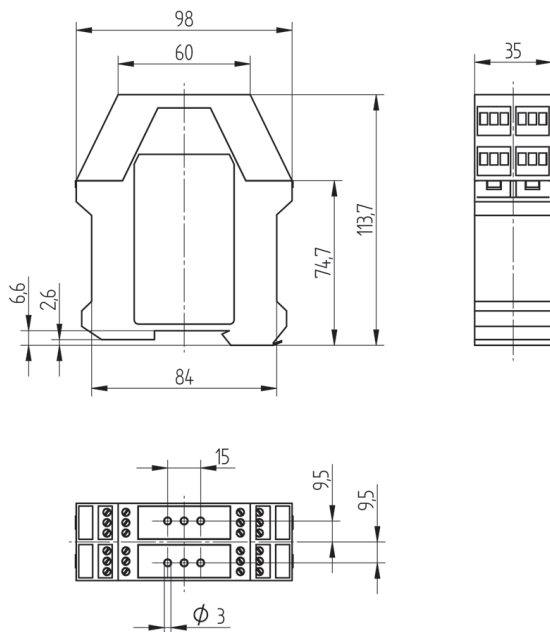

SM0-00CA00C1 Muting Indicator

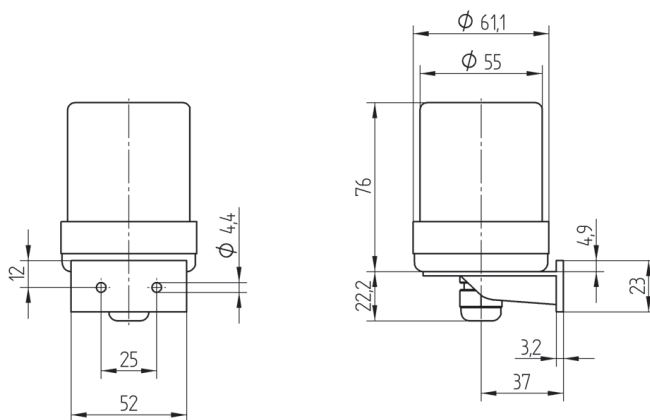

13 Accessories and Order Designation

Connector Unit

Individual Safety Light Barrier Control Unit without Muting: SS2-00VA000R2
 Individual Safety Light Barrier Control Unit with Muting: SS2-00VA000R3

Approved Safety Light Barriers

Type N	Range 0...20 m	Transmitter	SL2-00NS000H2
		Receiver	SL2-00NE000H2

Accessories

Muting Indicator	SM0-00CA00C1		
Muting Sensors	Transmitter	SN2003	
	Receiver	EN200PA3	

Connector Cable

M12×1, 4-pin Connector Cable

Length	Angle Plug		Straight Plug	
	PVC	PUR*	PVC	PUR*
2 m	S29-2M	S29-2MPUR	S23-2M	S23-2MPUR
5 m	S29-5M	S29-5MPUR	S23-5M	S23-5MPUR
10 m	S29-10M	-	S23-10M	S23-10MPUR

*PUR: halogen-free, suitable for use with drag chains

Notes:

- In order to procure a complete safety system, an Individual Light Barrier Control Unit, Light Barriers and the required Connector Cables must be ordered.
- Operating instructions are included in the scope of delivery.
- The transmitter and the receiver used for a given light barrier must always be of the same type.

14 Technical Data

14.1 Safety Light Barriers

Safety Type	Type 2 per EN 61496-1 and IEC 61496-2
Performance Level	EN ISO 13849-1:2008 Category 2 PL c (in combination with SS2-00VA000Rx)
Range	depends upon light barrier SL2-00NS000H2: 0...20 m
Opening angle	depends upon light barrier SL2-00NE000H2: ± 4°
Response time	< 30 ms (incl. Individual Light Barrier Control Unit SS2)
Electrical connection	M12 plug, 4 pins
Max. cable length	50 m with enclosable cross-section 0,5 mm ² 100 m with enclosable cross-section 1 mm ²
Protection	IP 67
Dimensions (h × l × t)	75 × 33 × 18 mm (SL2-00N) 81 × 75 × 34 mm (SL2-00T)
Temperature range	-25...60 °C (SL2-00N) -30...50 °C (SL2-00T)
Weight	80 g (SL2-00N) 125 g (SL2-00TE) 190 g (SL2-00TS)

14.2 Individual Light Barrier Control Unit

Safety Type	Type 2 per EN 61496-1
Performance Level	EN ISO 13849-1:2008 Category 2 PL c (in combination with SL2-00)
Sicherheitsintegritätslevel (only for SS2-00VA000R2)	SIL 1 per EN 61508 SILCL 1 per EN 62061
PFH_d	$3,16 \times 10^{-7}$ 1/h Probability of failure for the controller and up to 4 utilized safety light barriers.

T10_d

The OSSDs at the Individual Light Barrier Control Unit are comprised of mechanically connected contact relays. Frequency of use and load must be taken into consideration for this reason. The tables below specify the T10_d values for two different sets of working conditions, and differentiation is made between two loading cases each. Maximum operating time for the unit is specified with this value. After this point in time, PFH_d, SIL and PL values can no longer be guaranteed and replacement of the relays becomes mandatory. A T10_d value of greater than 20 years means that the operating time for the relays is greater than the test interval for the entire controller (i.e. 20 years, see also EN ISO 13849-1 and EN 62061).

- **Case 1:** Medium load with 4 light barriers
220 days a year, 16 hours a day (3520 hours per year)

Load	Switching interval	T10 _d
2 A at 230 V AC	30 s	1,89 a
	1 min	3,79 a
	5 min	18,94 a
	10 min	> 20 a
	1 h	> 20 a
	8 h	> 20 a
0,5 A at 24 V DC	30 s	0,95 a
	1 min	1,89 a
	5 min	9,47 a
	10 min	18,94 a
	1 h	> 20 a
	8 h	> 20 a

- **Case 2:** Heavy load with 4 light barriers
330 days a year, 16 hours a day (5280 hours per year)

Load	Switching interval	T10 _d
2 A at 230 V AC	30 s	1,26 a
	1 min	2,53 a
	5 min	12,63 a
	10 min	> 20 a
	1 h	> 20 a
	8 h	> 20 a
0,5 A at 24 V DC	30 s	0,63 a
	1 min	1,26 a
	5 min	6,31 a
	10 min	12,63 a
	1 h	> 20 a
	8 h	> 20 a

Supply power	24 V DC \pm 20 %, SELV (IEC 60204)/PELV (IEC 60950)
Power consumption	< 5 W
Safety outputs	2, NO contacts (2 A; 250 V)
Fuse	max. 4A, delay
Response time	< 30 ms (incl. Safety Light Barriers SL2)
Switching current	
Signal control	< 100 mA, PNP output
Voltage drop Signal control	< 3 V, PNP output
Contact monitoring input	forcibly guided NC contacts (20 mA; 24 V DC)
Max. changeover time	300 ms
Min, test time, test input	40 ms
Muting sensor inputs	2 pairs of sensors (transmitter/receiver) 24 V DC, PNP
Muting enable input	24 V DC, PNP
Override time limit	60 min.
Operating modes	restart inhibit or automatic restart
LED displays	supply power – channel status – failure – status of the muting sensors – muting – override request
Connectable	
Safety light barriers	1 – 4 (with 1 static PNP safety output)
Mounting	Top hat rail 35 mm according to EN 6071
Connection	screw terminals with polarity reversal protection
Enclosable cross-section	0,14...2,5 mm ²
Protection	IP 20
Dimensions (h × l × t)	99 × 35 × 114,5 mm
Temperature range	0...55 °C
Weight	215 g

15 Checklist

This checklist is intended to provide assistance during initial start-up. It does not eliminate the need for testing before initial start-up, or for periodic tests conducted by appropriately trained persons.

1. Standards and Directives, ESPE Selection		
Are the safety precautions based upon the directives/standards which are applicable for the machine?	Yes	No
Are the utilized directives and standards listed in the declaration of conformity?	Yes	No
Is the safety device in compliance with the required safety level?	Yes	No
2. Safety Clearance		
Has safety clearance been calculated in accordance with the valid formulas for securing points of danger, and in consideration of resolution, ESPE response time, response time of any utilized safety interface and machine over-travel time?	Yes	No
Has machine over-travel time been measured, specified, documented (at the machine and/or in the machine's documentation) and adapted to the ESPE installation setup.	Yes	No
Has the safety clearance between the point of danger and the safety field been adhered to?	Yes	No
3. Access to the Point of Danger		
Is it only possible to access the point of danger via the ESPE's safety field?	Yes	No
Is it assured that persons are unable to remain within the danger zone unprotected (e.g. by means of mechanical protection against side-stepping, or by means of cascading), and are the implemented measures protected against manipulation?	Yes	No
Have additional mechanical protective measures been installed which prevent reaching under, over or around the safety field, and are they protected against manipulation?	Yes	No
4. Installation		
Have the components of the ESPE been correctly attached and secured against loosening, shifting and rotation after adjustment?	Yes	No
Is the external condition of the ESPE and all associated accessories flawless?	Yes	No
Has the control device for resetting the ESPE been correctly installed outside of the danger zone, and is it functional?	Yes	No
5. Incorporation into the Machine		
Have the safety outputs (OSSDs) been incorporated into the downstream machine controls in accordance with the required controller category, and have they been connected in accordance with the wiring diagrams?	Yes	No
Are the switching elements which are controlled by the ESPE (e.g. contactors, valves) monitored?	Yes	No
6. Functionality		
Is the ESPE effective during the entire duration of the machine's hazardous motion?	Yes	No
If a hazardous state has been initialized, is it stopped when the ESPE is switched off, if the operating mode or any of the function types are changed, or if switching to another safety device occurs?	Yes	No
Are the specified safety functions effective for each and every configuration?	Yes	No
Has the safety function been tested in accordance with the inspection instructions included in the operating instructions?	Yes	No

16 Certification

The safety device, consisting of an SS2-00VA000R3 Individual Light Barrier Control Unit and SL2-00NE000H2/SL2-00NS000H2 Safety Light Barriers, has the following approvals:



17 EU Declaration of Conformity

17.1 Declaration of conformity for Individual Safety Light Barrier Control Units SS2

EU Konformitätserklärung EU Declaration of Conformity (DoC)



Name und Anschrift des Herstellers / Name and address of manufacturer:

wenglor sensoric GmbH
wenglor Straße 3
88069 Tett nang / GERMANY

Diese Erklärung gilt für die folgenden Produkte: This declaration applies to the following products:

SS2-00VA000R2
SS2-00VA000R3

Wir bestätigen die Übereinstimmung mit den grundlegenden Anforderungen der Europäischen Richtlinien
We confirm compliance with the essential requirements of the European Directives

Richtlinie / Directive	Fundstelle / Reference
EMV / EMC	2014/30/EU Amtsblatt / Official Journal L96 29.03.2014
Maschinen / MD	2006/42/EG Amtsblatt / Official Journal L157 9.06.2006

Folgende harmonisierte Normen wurden angewandt:

The following harmonized standards have been used:

EN 61496-1:2013
IEC 62061 Ed.1 (SIL CL 1)

EN ISO 13849-1:2008 (Cat. 2, PL c)
EN 50178:1997
EN 55022:2010

Produkt-Beschreibung

Product description

*Sicherheits-Einzelschrankensteuerung
Sicherheits-Bauteil nach 2006/42/EG Anhang IV
Seriennummer: Lt. Typenschild*

*Individual Safety Light Barrier Control Unit
Safety component per 2006/42/EC annex IV
Serial Number: See rating plate*

Benannte Stelle / Zertifikat Nr.
TÜV SÜD Product Service GmbH
Ridlerstraße 65
D-80339 München

Notified Body / Certificate Nr.
NB Nr. 0123
Z10 15 03 40594 031

Dr. Alexander Ohl ist bevollmächtigt, die technischen Unterlagen zusammenzustellen.

Dr. Alexander Ohl is authorized to compile the technical documentation.

Diese Erklärung stellvertretend für den Hersteller wird abgegeben durch:

On account of the manufacturer, this declaration is given by:

Dr. Alexander Ohl

Leiter Forschung & Entwicklung / Head of Research & Development

Tett nang, 20.04.2016
Ort / Place Datum / Date

Unterschrift / Signature

17.2 Declaration of conformity for Safety Through Beam Sensor SL2

EU Konformitätserklärung EU Declaration of Conformity (DoC)



Name und Anschrift des Herstellers / Name and address of manufacturer:

wenglor sensoric GmbH
wenglor Straße 3
88069 Tettang / GERMANY

Diese Erklärung gilt für die folgenden Produkte: This declaration applies to the following products:

SL2-00NS000H2, SL2-00NE000H2
SL2-00NS000H3, SL2-00NE000H3

Wir bestätigen die Übereinstimmung mit den grundlegenden Anforderungen der Europäischen Richtlinien
We confirm compliance with the essential requirements of the European Directives

Richtlinie / Directive	Fundstelle / Reference
EMV / EMC	2014/30/EU Amtsblatt / Official Journal L96 29.03.2014
Maschinen / MD	2006/42/EG Amtsblatt / Official Journal L157 9.06.2006

Folgende harmonisierte Normen wurden angewandt:

The following harmonized standards have been used:

EN 61496-1:2013 (Type 2)
EN 61496-2:2013 (Type 2)

EN ISO 13849-1:2008 (Cat. 2, PL c)
EN 50178:1997
EN 61000-6-4:2007/A1:2011

Produkt-Beschreibung

Product description

*Sicherheits-Einweglichtschranke (in Verbindung mit sicherheits-gerichteter Steuerung)
Berührunglos Wirkende Schutzeinrichtung
Sicherheits-Bauteil nach 2006/42/EG Anhang IV*

*Safety Through Beam Sensor (in combination with Individual Safety Light Barrier Control Unit)
Electro-Sensitive Protective Equipment
Safety component per 2006/42/EC annex IV*

Benannte Stelle / Zertifikat Nr.

TÜV SÜD Product Service GmbH
Ridlerstraße 65
D-80339 München

Notified Body / Certificate Nr.

NB Nr. 0123
Z10 14 12 40594 028

Dr. Alexander Ohl ist bevollmächtigt, die technischen Unterlagen zusammenzustellen.

Dr. Alexander Ohl is authorized to compile the technical documentation.

Diese Erklärung stellvertretend für den Hersteller wird abgegeben durch:

On account of the manufacturer, this declaration is given by:

Dr. Alexander Ohl

Leiter Forschung & Entwicklung / Head of Research & Development

Tettang, 20.04.2016
Ort / Place Datum / Date

Unterschrift / Signature