

# Fork Sensor

## P1HJ007

## LASER

Part Number

InoxSens



- Collimated laser beam (0.6 mm diameter over the entire fork width)
- Recognition of transparent objects
- Rugged, corrosion-free V4A stainless steel housing in hygienic design
- Teach-in key and external teach-in

Fork sensors have a collimated laser beam with a very small diameter of 0.6 mm over the entire fork width. As a result, they're capable of detecting extremely small parts down to a size of just 40 µm and even transparent objects at high speeds of up to 10 kHz. The innovative layout of the fork sensors in hygienic design permits various fork widths within a range of 50 to 220 mm, and allows contamination and cleaning agents to flow off of the surface in an ideal manner.

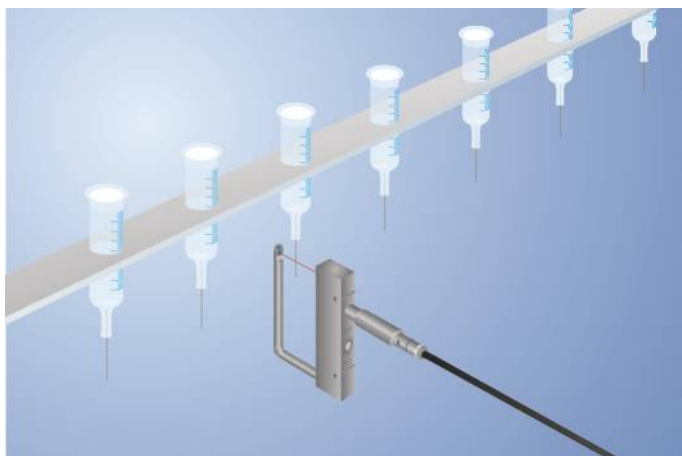

### Technical Data

Optical Data	
Fork Width	50 mm
Smallest Recognizable Part	40 µm
Smallest Detectable Gap	50 µm
Switching Hysteresis	< 10 %
Light Source	Laser (red)
Service Life (T = +25 °C)	100000 h
Laser Class (EN 60825-1)	2
Max. Ambient Light	10000 Lux
Light Spot Diameter	0,6 mm
Repeat Accuracy	< 5 µm

Electrical Data	
Supply Voltage	10...30 V DC
Current Consumption (U <sub>b</sub> = 24 V)	< 20 mA
Switching Frequency	10 kHz
Response Time	50 µs
Off-Delay	0...100 ms
Temperature Range	-25...60 °C
Switching Output Voltage Drop	< 2,5 V
PNP Switching Output/Switching Current	100 mA
Short Circuit Protection	yes
Reverse Polarity Protection	yes
Overload Protection	yes
Teach Mode	NT, MT
Protection Class	III

Mechanical Data	
Setting Method	Teach-In
Housing Material	Stainless Steel 316L
Optic Cover	Plastic
Degree of Protection	IP69K
Connection	M8 × 1; 4-pin
Ecolab	yes

Safety-relevant Data	
MTTFd (EN ISO 13849-1)	1615,89 a

PNP NO/NC switchable	●
Connection Diagram No.	<b>152</b>
Control Panel No.	<b>115</b>
Suitable Connection Equipment No.	<b>7</b>
Suitable Mounting Technology No.	<b>570</b>

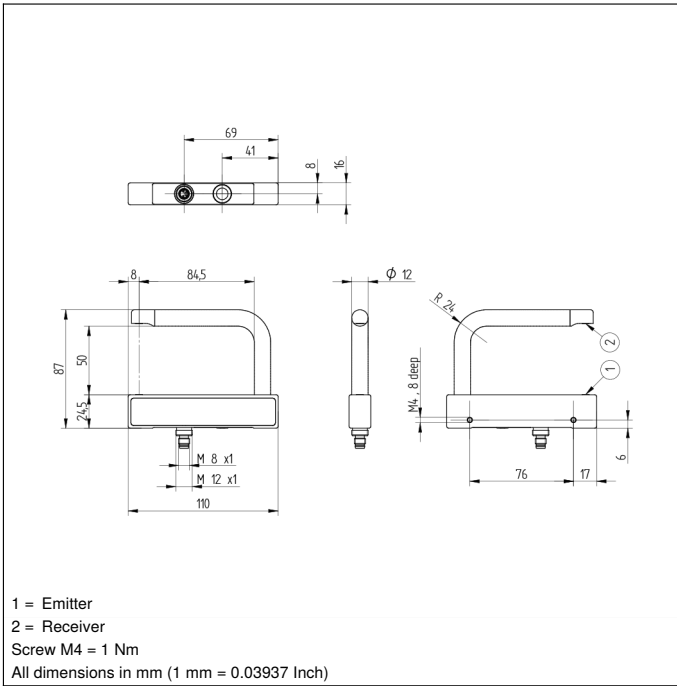

### Ctrl. Panel

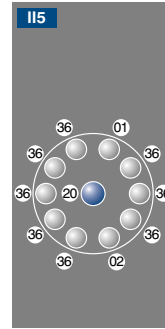

- 01 = Switching Status Indicator
- 02 = Contamination Warning
- 20 = Enter Button
- 36 = Mode Indicator

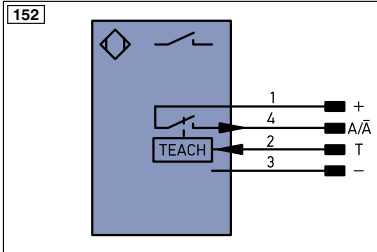

### Legend

+	Supply Voltage +	PT	Platinum measuring resistor	EN <sup>A</sup> RS422	Encoder A/Ā (TTL)
-	Supply Voltage 0 V	nc	not connected	EN <sup>B</sup> RS422	Encoder B/B̄ (TTL)
~	Supply Voltage (AC Voltage)	U	Test Input	EN <sup>A</sup>	Encoder A
A	Switching Output (NO)	Ū	Test Input inverted	EN <sup>B</sup>	Encoder B
Ā	Switching Output (NC)	W	Trigger Input	A <sup>MIN</sup>	Digital output MIN
V	Contamination/Error Output (NO)	W-	Ground for the Trigger Input	A <sup>MAX</sup>	Digital output MAX
Ṽ	Contamination/Error Output (NC)	O	Analog Output	A <sup>OK</sup>	Digital output OK
E	Input (analog or digital)	O-	Ground for the Analog Output	SY <sup>in</sup>	Synchronization In
T	Teach Input	BZ	Block Discharge	SY <sup>OUT</sup>	Synchronization OUT
Z	Time Delay (activation)	AWV	Valve Output	OL <sup>T</sup>	Brightness output
S	Shielding	a	Valve Control Output +	M	Maintenance
RxD	Interface Receive Path	b	Valve Control Output 0 V	rsv	reserved
TxD	Interface Send Path	SY	Synchronization	Wire Colors according to DIN IEC 757	
RDY	Ready	SY-	Ground for the Synchronization	BK	Black
GND	Ground	E+	Receiver-Line	BN	Brown
CL	Clock	S+	Emitter-Line	RD	Red
E/A	Output/Input programmable	±	Grounding	OG	Orange
	IO-Link	S <sup>n</sup> R	Switching Distance Reduction	YE	Yellow
PoE	Power over Ethernet	Rx+/-	Ethernet Receive Path	GN	Green
IN	Safety Input	Tx+/-	Ethernet Send Path	BU	Blue
OSSD	Safety Output	Bus	Interfaces-Bus A(+)/B(-)	VT	Violet
Signal	Signal Output	L <sup>a</sup>	Emitted Light disengageable	GY	Grey
Bl_D+/-	Ethernet Gigabit bidirect. data line (A-D)	Mag	Magnet activation	WH	White
EN <sup>0</sup> RS422	Encoder 0-pulse 0-0̄ (TTL)	RES	Input confirmation	PK	Pink
		EDM	Contactur Monitoring	GNYE	Green/Yellow

