



- Non-contact, absolute position encoder
- Automatic detection of dirt accumulation
- Output of position and speed
- Optimized for all control and elevator systems
- Slip-free system
- No reference run required
- Quick mounting
- RS 422 interface
- High resolution

WCS3R-LS24A



Technical data

General specifications

Passage speed	v	≤ 2.2 m/s
Measuring range		max. 100 m
Free tolerances to code rail		horizontal: 31 mm (± 15.5 mm) vertical: 28 mm (± 14 mm)
Resolution		± 1 mm

Functional safety related parameters

MTTF _d		50 a
Mission Time (T _M)		10 a
Diagnostic Coverage (DC)		0 %

Indicators/operating means

Operating display		LED green: power on
Data flow display		LED yellow: data communication active
Error display		LED red flashing: read head outside of code rail solid on: internal diagnostic test failed

Electrical specifications

Operating voltage	U _B	10 ... 30 V DC
Power consumption	P ₀	2 VA

Interface

Interface type		RS 422
Data output code		binary code
Protocol		see protocol description
Transfer rate		Baud rate 19.2 kBit/s

Standard conformity

Emitted interference		DIN EN 61000-6-4 , DIN EN 12015
Noise immunity		DIN EN 61000-6-2 , DIN EN 12016
Shock resistance		DIN EN 60068-2-27, half sine 30 g, 18 ms
Vibration resistance		DIN EN 60068-2-6, sine, 5 g, 10 - 2000 Hz, 10 cycles

Ambient conditions

Operating temperature		0 ... 60 °C (32 ... 140 °F)
Storage temperature		-40 ... 85 °C (-40 ... 185 °F)
Relative humidity		90 % , noncondensing

Mechanical specifications

Connection type		8-pin, M12 x 1 connector
Protection degree		IP54
Material		
Housing		ABS , PC (Polycarbonate)
Mass		500 g

General information

Ordering information		Mounting plate included with delivery
----------------------	--	---------------------------------------

Approvals and certificates

CSA approval		cCSAus Certified, General Purpose Class 2 power source
--------------	--	---

CCC approval

Products with a maximum operating voltage of ≤ 36 V do not bear a CCC marking because they do not require approval.

Dimensions

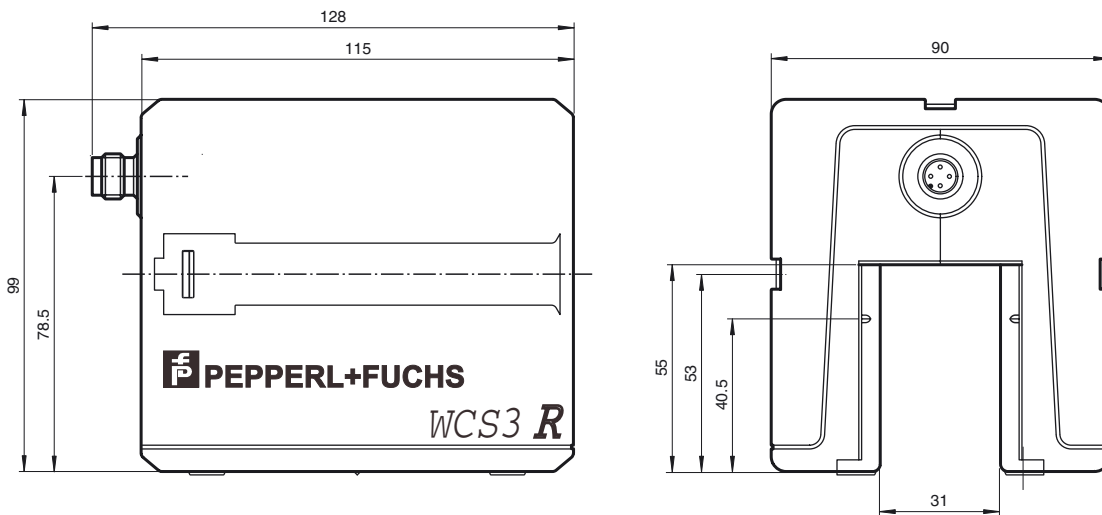

Mounting plate

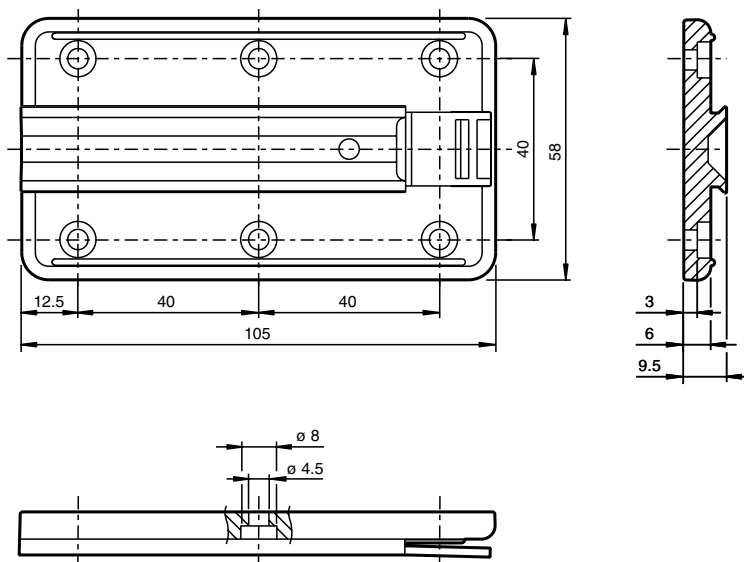

Date of edition 2012-01-25

Electrical connection

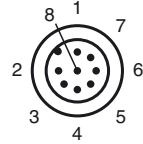
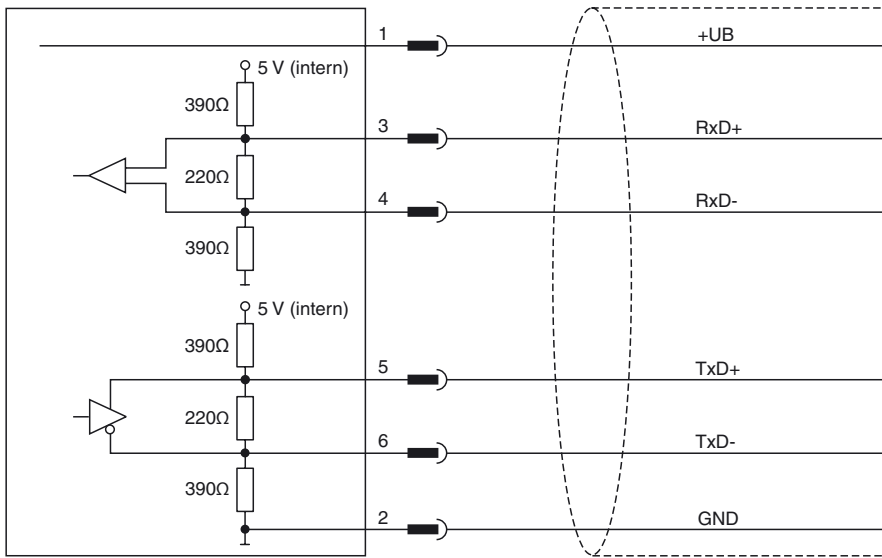

Interface description

Byte format

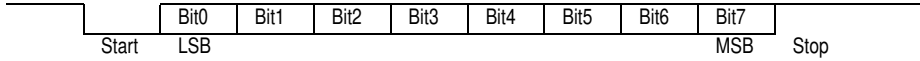

Data protocol

Request bytes

Byte	0	0	0	0	0	0	1	0
	Bit7							Bit0

Cycle time: 10 ms

Answer telegram of the read head

Bit	7	6	5	4	3	2	1	0
Byte1	XP07	XP06	XP05	XP04	XP03	XP02	XP01	XP00
Byte2	XP15	XP14	XP13	XP12	XP11	XP10	XP09	XP08
Byte3	XP23	XP22	XP21	XP20	XP19	XP18	XP17	XP16
Byte4	Out	OutAll	DB	Status	0	Err02	Err01	Err00

Output in increments of 0.25 mm

Out = 1: Read head partly outside of the code rail

OutAll = 1: Read head completely outside of the code rail

DB = 1: Soiled read head optics

Status: 0 = error; 1 = no error

Error: Error number in Err02 ... Err00