

BIC IO-Link unidirectional 500 mA, IP67, 11 bytes User's Guide

 **IO-Link**



Content

1	User instructions	3
1.1.	Validity of the Guide	3
1.2.	Typographical Conventions	3
	Enumerations	3
	Syntax	3
	Cross references	3
1.3.	Symbols	3
1.4.	Abbreviations	3
1.5.	Differing views	3
2	Safety	4
2.1.	Proper Use	4
2.2.	Authorized Personnel	4
2.3.	Obligations of the Operating Company	4
2.4.	Malfunctions	4
2.5.	Meaning of the Warning Notices	4
	4	
2.6.	Certification	4
3	Construction and Function	5
3.1.	Construction	5
3.2.	Function	5
3.3.	Features, Advantages	5
3.4.	Indicators	5
4	Function indicator and diagnosis	6
4.1.	Base indicators	6
4.2.	Remote indicators	6
5	Installation and Connection	7
5.1.	Mutual Interference	7
5.2.	Installation in Metal	7
5.3.	Angular offset	7
5.4.	connection	8
5.5.	Series connection	8
6	Technical Data Base	9
6.1.	Dimension	9
6.2.	Mechanical data	9
6.3.	Operating conditions	9
6.4.	Electrical data	9
6.5.	Electrical connection	9
7	Technical Data Remote	10
7.1.	Dimension	10
7.2.	Mechanical data	10
7.3.	Operating conditions	10
7.4.	Electrical data	10
7.5.	Electrical connections M12, 5-pin, socket	10
8	IO-Link communication	11
8.1.	Process data	11
8	IO-Link-communication	12
8.2.	Parameters	12
8.3.	Events	12
	Event 1	12
	Event 2	12
9	Accessories	13
9.1.	Connectors	13
9.2.	Installation accessories	13
9.3.	Active components	13

Balluff Network Interface

10	Type Designation Code	14
10.1.	Type Code	14
10.2.	Order code	14

1 User instructions

1.1. Validity of the Guide

This manual describes the structure, function and installation of the Balluff Uni IO-Link inductive coupler. It is valid for types:
Base BIC 1I0-IAA50-M30MI3-SM4A4A and
Remote BIC 2I0-IAA50-M30MI3-SM4A5A
Remote BIC 2I0-IAA50-M30MI3-BPX04-002-M45A (see type code)

The guide is intended for qualified technical personnel. Read the guide before you install and operate the devices.

1.2. Typographical Conventions

The following typographical conventions are used in this guide.

Enumerations

Enumerations are shown as a list with bullet points.

- Entry 1,
- Entry 2.

Syntax

Numbers

- Decimal numbers are shown without additional indicators (e.g. 123),
- Hexadecimal numbers are shown with the additional indicator hex (e.g. 00hex).

Cross references

Cross-references indicate where further information on the topic can be found

1.3. Symbols



Attention!

This symbol indicates a security notice which must be observed.



Note

This symbol indicates general notes.



IO-Link

This device is IO-Link-capable.

1.4. Abbreviations

BIC	Balluff Inductive Coupler
EMC	Electromagnetic Compatibility
FE	Function Ground

1.5. Differing views

Product views and images in this manual may differ from the product described. They are intended to serve only as illustrations.

Balluff Inductive Coupler

Base BIC 1I0-IAA50-M30MI3-SM4A4A and

Remote BIC 2I0-IAA50-M30MI3-SM4A5A

Remote BIC 2I0-IAA50-M30MI3-BPX04-002-M45A

2 Safety

Important!

Before commissioning, carefully read the operating manual.

2.1. Proper Use

The device is designed to replace a plug connection in order to ensure contact-free data transmission.

The system must not be used in applications in which the safety of persons is dependent on the function of the device.

Warranty and liability claims against the manufacturer are rendered void by:

- Unauthorized tampering
- Improper use
- Use, installation or handling contrary to the instructions provided in this operating manual

2.2. Authorized Personnel

Installation and commissioning may only be performed by trained specialist personnel.

2.3. Obligations of the Operating Company

The operating company must ensure that the locally applicable safety regulations are observed.

The device corresponds to EMC Class A and can cause radio interference. The operating company must take appropriate precautions to prevent radio interference.

The device may only be used with an approved power supply. (see "Technical Data"). Only approved cables may be used.

2.4. Malfunctions

In the event of defects and device malfunctions that cannot be rectified, the device must be taken out of operation and protected against unauthorized use.

2.5. Meaning of the Warning Notices

The warning notices in this guide and the measures described for avoiding dangers must be observed. The warning notices contain the following signal words that indicate the severity of the danger:

- **Danger:**
Indicates an immediate danger that will result in a severe injury or death of persons if not observed.
- **Warning:**
Indicates a potential danger that may result in a severe injury or death of persons if not observed.
- **Caution:**
Indicates a potential danger that may result in light injury to persons or damage to property if not avoided.
- **Attention:**
Indicates a situation that may result in property damage if not avoided.

When working with this product, the following warning notices apply:



Caution!

Risk of burning on hot surfaces!

The active surface heats up even under normal operating conditions.

Keep away hands and objects from the active surface.

Avoid contact of metal objects on the active surface. Fire hazard

2.6. Certification



With the CE marking, we confirm that our products meet the requirements of EC directives 2004/108/EC (EMC) and the EMC law.

In our EMC laboratory, which is accredited by DATech for testing electromagnetic compatibility, evidence has been provided that the Balluff products satisfy the EMC requirements of the generic standards:

EN 61000-6-4 (Interference emission) and

EN 61000-6-2 (Immunity to interference)

3 Construction and Function

3.1. Construction

The BIC components are designed for applications in an IO-Link system. They are connected to the host master module via the IO-Link protocol. The system consists of the following two components:

- Base (master side)
- Remote (device)

The components are enclosed in a brass housing protected acc. to IP 67

Master

The master is connected to the base.

Devices

The remote is connected to the device.

When IO-Link devices are connected, observe the following:

- Make certain that the total power consumption is not greater than that of the base.
- Use only devices with inputs

3.2. Function

This set transfers power from the base to the remote via an air bridge; the base then receives IO-Link data back from the remote. The base and remote must match one another with respect to size.

The IO-Link device is wired to the remote. The remote is only inductively coupled to the base, however. The base transmits the energy for the IO-Link device to the remote. The IO-Link communication of the IO-Link device is transmitted from the remote to the base. The energy available for the IO-Link device is dependent on the distance and on the offset between base and remote and is, therefore, limited. For this reason, the total current consumption of the connected IO-Link device must not exceed the maximum power output of the remote.

3.3. Features, Advantages

- The cable length between the remote and IO-Link device can be a maximum of 20 meters.
- LED indicator on the remote and base for operational readiness and operating voltage
- An angular offset is possible between base and remote
- Simple wiring of e.g. rotary tables, replaceable punch heads etc.
- M12 plug connection on the systems
- Control of capacitive loads
- More power in the same structural shape
- Large operating voltage range

3.4. Indicators

If the supply voltage is applied correctly, the green LEDs on the base and remote illuminate. If the IO-Link communication is active, the green LED on the base flashes inversely. The base's red LED illuminates as soon as an error has been detected in the system. As soon as the remote moves out of the secured working range, the red LEDs on the base begin to flash. If the red LED illuminates and stays on, there is an error in the IO-Link communication. If no device is connected to the remote but the remote is within range of the base, the green LEDs flash.

Balluff Inductive Coupler
Base BIC 1I0-IAA50-M30MI3-SM4A4A and
Remote BIC 2I0-IAA50-M30MI3-SM4A5A
Remote BIC 2I0-IAA50-M30MI3-BPX04-002-M45A

4 Function indicator and diagnosis

4.1. Base indicators

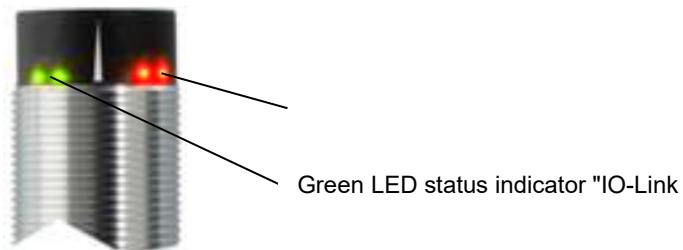

Signaling	Function
Green, static	Supply voltage OK No IO-Link communication
Green, flashing inversely	IO-Link communication between master and base is OK
Red, flashing	No remote detected
Red off	Remote present, IO-Link communication OK
Red, static	Remote present, no IO-Link communication to connected device

4.2. Remote indicators

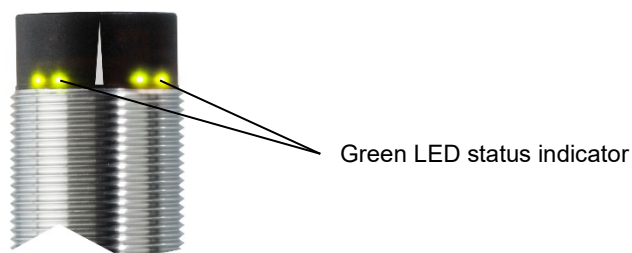

Signaling	Function
Green – static	The remote is located within the working range of a base, communication between the remote and IO-Link device is OK
Green, flashing	No IO-Link device present

5 Installation and Connection

5.1. Mutual Interference



Attention!

Improper mounting may affect the function of the system and lead to damage. The spacings specified for installation must be adhered to.

To prevent mutual interference with adjacent bases or remotes, the specified minimum distances must be adhered to:

Type	A (mm)
BIC 110-IAA50-M30MI3-SM4A4A	100
BIC 210-IAA50-M30MI3-SM4A5A	100
BIC 210-IAA50-M30MI3-BPX04-002-M45A	100

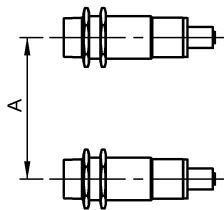

5.2. Installation in Metal



Attention!

Device damage due to induction effects!
Metallic objects on the coil cap cause the objects to be heated.
Install the components so that no metallic objects can collect on the coil cap.
There is a fire hazard!

When installing in metal, the specified minimum distances to the surrounding sides of the metallic object must be maintained. Otherwise, the transmission distance between transmitter and receiver changes.

The transmission distance can also be influenced by the type of metal.

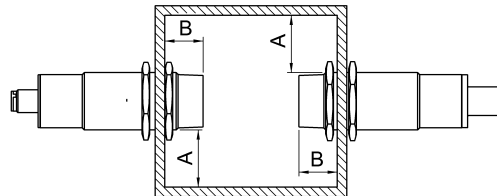

Type	A (mm)	B (mm)
BIC 110-IAA50-M30MI3-SM4A4A	30	20
BIC 210-IAA50-M30MI3-SM4A5A	30	20
BIC 210-IAA50-M30MI3-BPX04-002-M45A	30	20

5.3. Angular offset

The permissible angular offset ensures proper function, even in difficult installation conditions:

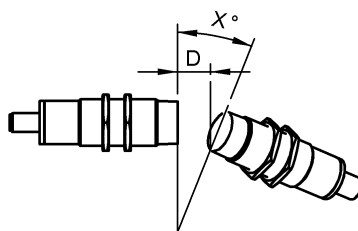

Distance D (mm)	Angle X
1	18°
2	12°
3	10°
4	5°
5	0°

Balluff Inductive Coupler

Base BIC 110-IAA50-M30MI3-SM4A4A and Remote BIC 210-IAA50-M30MI3-SM4A5A

Remote BIC 210-IAA50-M30MI3-BPX04-002-M45A

5 Installation and Connection

5.4. Connection

Attention!
 Device damage due to incorrect voltage supply!
 Malfunctions may occur if the ripple is too high or if the output voltage is not regulated.
 Use only approved, regulated voltage supplies.

Attention!
 The remote (receiver) may be damaged by voltage spikes if cables that are too long are used!
 To satisfy the EMC requirements, the receiver cable must not be longer than 20 m.

5.5. Series connection

Two BIC systems can be connected in series.

Caution!
 This cuts the power in half from 500 mA to 250 mA. The cable length between the individual components in each case must not be larger than 20 m. An angular offset can no longer be guaranteed. For that reason, the systems should be positioned accurately. It is not possible to have an air gap larger than 5mm.

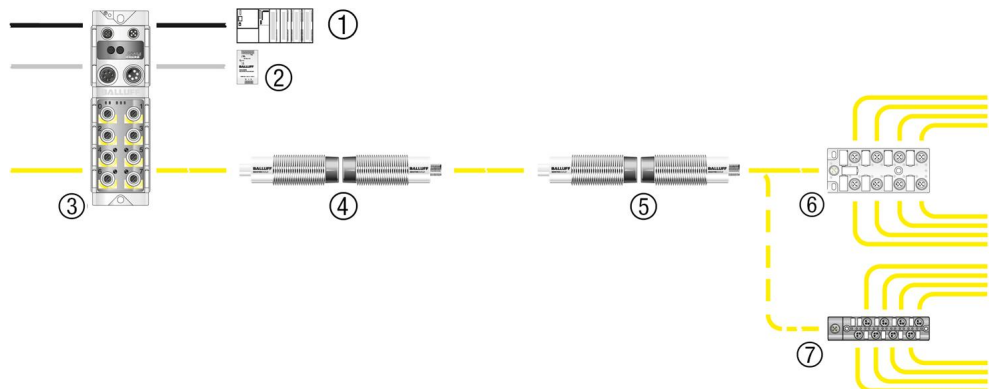

No.	Legend for graphic:	Balluff components
1	Profibus controller	-
2	Balluff power supply	BAE PS-XA-1W-24-050-003
3	Balluff IO-Link master	BNI PBS-502-001-Z001
4+5	BIC IO-Link system	BIC 110-IAA50-M30MI3-SM4A4A BIC 210-IAA50-M30MI3-SM4A5A BIC 210-IAA50-M30MI3-BPX04-002-M45A
6	Balluff sensor hub	BNI IOL-104-000-K006
7	Balluff sensor hub alternative to 6	BNI IOL-104-000-K021

6 Technical Data Base

6.1. Dimension

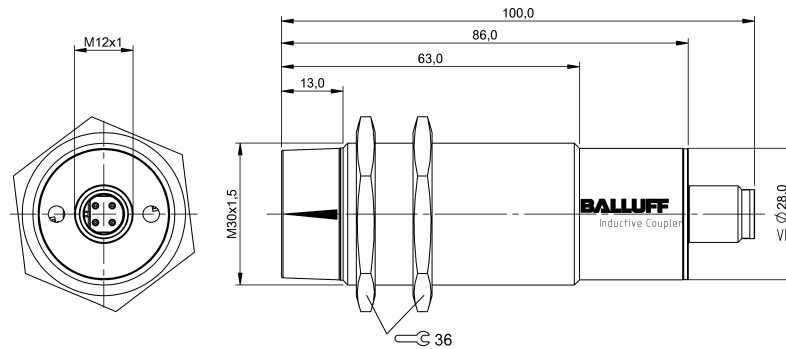

6.2. Mechanical data

Housing material	Brass
Degree of protection as per IEC 60529	IP 67 (only in plugged-in and screwed-down state)
Connection type	M12, A-coded
Dimensions (D x L in mm)	M30 X 100
Weight	Approx. 160 g
Tightening torque	70 Nm

6.3. Operating conditions

Transmission distance	1 to 5 mm
Operating temperature T_a	0 °C to 55 °C
Storage temperature range	-25 °C to 75 °C

6.4. Electrical data

Supply voltage	24 V DC +-10%, acc. to EN 61131-2
Operating current at 24 V	Max. 1 A
Standby current	Max. 100 mA
Overload protection	Yes

6.5. Electrical connection

M12, 4-pin, connector

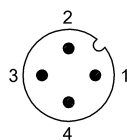

Pin	Signal	Meaning
1	+24 V	Input voltage
2	nc	NC
3	0V	GND,
4	C/Q, IO Link	C/Q, IO Link

Balluff Inductive Coupler

Base BIC 110-IAA50-M30MI3-SM4A4A and

Remote BIC 210-IAA50-M30MI3-SM4A5A

Remote BIC 210-IAA50-M30MI3-BPX04-002-M45A

7 Technical Data Remote

7.1. Dimension

Connector
SM4A5A

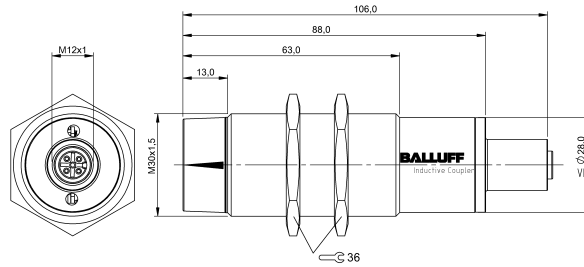

Cable
BPX04-002-M45A

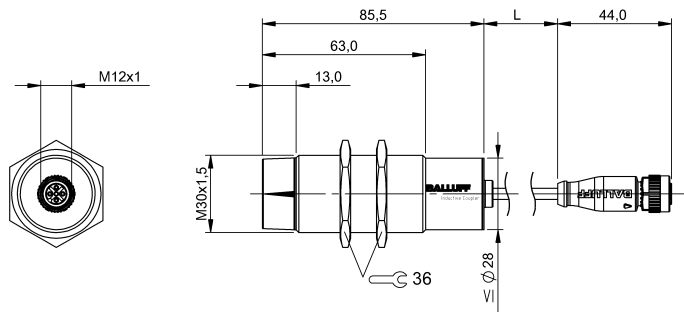

7.2. Mechanical data

Housing material	Brass
Degree of protection as per IEC 60529	IP 67 (only in plugged-in and screwed-down state)
Connection type	M12, A-coded / Cable PUR
Dimensions (D x L in mm)	M30 X 106
Weight	Approx. 160 g
Tightening torque	70 Nm

7.3. Operating conditions

Transmission distance	1 to 5 mm
Operating temperature T_a	0 °C to 55 °C
Storage temperature range	-25 °C to 75 °C

7.4. Electrical data

Supply voltage	24 V DC +5 %
Output current	500 mA
Short-circuit protected	Yes
Output peak current	Max. 800 mA
Operational readiness	< 100 ms

7.5. Electrical connections M12, 5-pin, socket

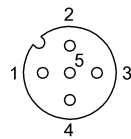

Pin	Signal	Meaning
1	+24 V	Output voltage
2	-	NC
3	0V	GND
4	C/Q, IO Link	C/Q, IO Link
5	nc	NC

8.1. Process data

The "Base" transmits 11 bytes of input via the IO-Link. The first ten represent the data of the IO-Link device connected to the "Remote", while the 11th byte contains status information. If an IO-Link device that outputs less than 10 bytes of input data is connected to the "Remote", the remaining, unused bytes are transmitted with "0".

Bytes 0 to 9							
7	6	5	4	3	2	1	0
Process data of the connected IO-Link devices.							

Byte 10							
7	6	5	4	3	2	1	0
Not used	Not used	Not used	Not used	Status "Supply remote"	Status "Short remote"	Status "Inzone"	Status "Com"

* All unused bits and bytes are output with "0".

Explanation of the status bits

Status	Meaning
"Supply remote"	Voltage at the remote is less than 18V
"Short remote"	Short-circuit at the IO-Link interface of the remote
"Inzone"	No remote detected
"Com"	No IO-Link device detected



Note

Process data update time is max. 200ms

Balluff Inductive Coupler
Base BIC 110-IAA50-M30MI3-SM4A4A and
Remote BIC 210-IAA50-M30MI3-SM4A5A
Remote BIC 210-IAA50-M30MI3-BPX04-002-M45A

8 IO-Link-communication

8.2. Parameters

Various base parameters can be accessed via IO-Link. All parameters are read-only, so they involve information, not configuration options. The "Identification data" can contain texts and information about the base. The Direct Parameter page of the IO-Link device connected to the remote is displayed in the "Parameter data".

	DPP	SPDU		Description	Length	Default value
	Index	Index	Sub Index			
Identification data	0 x 07			Vendor ID	2 bytes	0 x 0378
	0 x 08			Device ID	3 bytes	0 x 050602
	0 x 09					
	0 x 0A					
	0 x 0B					
		0 x 10	0	Vendor name	7 bytes	BALLUFF
		0 x 11	0	Vendor text	15 bytes	www.balluff.com
		0 x 12	0	Product name	37 bytes	BIC 110-IAA50-M30MI3-SM4A4A
		0 x 13	0	Product ID	7 bytes	BIC0053
		0 x 14	0	Product text	34 bytes	BIC IOL Base extended
	0 x 16	0	Hardware revision	3 bytes		
	0 x 17	0	Firmware revision	3 bytes		
Parameterization data		0 x 40 64	0 1 – 16	Direct Parameter page of the IO-Link device on the remote	16 bytes	

8.3. Events



	Event classification			Detailed information			
	Mode	Type	Instance				
Event 1	0 x F3			0 x 5112			
	0 x C0	0 x 30	0 x 03	0 x 5000	0 x 0100	0 x 0010	0 x 0002
	coming	Error	Application	Hardware	Supply	Supply low voltage	U2 = supply + 24 V
	Supply voltage is too low						
Event 2	0 x B3			0 x 5112			
	0 x 80	0 x 30	0 x 03	0 x 5000	0 x 0100	0 x 0010	0 x 0002
	going	Error	Application	Hardware	Supply	Supply low voltage	U2 = supply + 24 V
	Supply voltage is OK again						

9 Accessories





9.1. Connectors

Description	Description	Remarks
PUR for base, open cable end	BCC M415-0000-1A-003-PX0434-xxx	XXX -> cable length
PUR for base and remote as jumper	BCC M415-M414-3A-304-PX0434-xxx	XXX -> cable length
PUR for remote, open cable end	BCC M415-0000-1A-003-PX0434-xxx	XXX -> cable length

9.2. Installation accessories

Description	Description	Fig.
	BES 30.0-BS-1	
	BES 30-HW-1	

9.3. Active components

Description	Description	Fig.
Profibus connection for base	BNI PBS-507-001-Z011	
Profibus connection for base	BNI PBS-502-001-Z001	
Profibus connection for base	BNI PBS-504-001-K008	
Profinet connection for base	BNI PNT-502-105-Z015	

Balluff Inductive Coupler
Base BIC 1I0-IAA50-M30MI3-SM4A4A and
Remote BIC 2I0-IAA50-M30MI3-SM4A5A
Remote BIC 2I0-IAA50-M30MI3-BPX04-002-M45A

10 Type Designation Code

10.1. Type Code

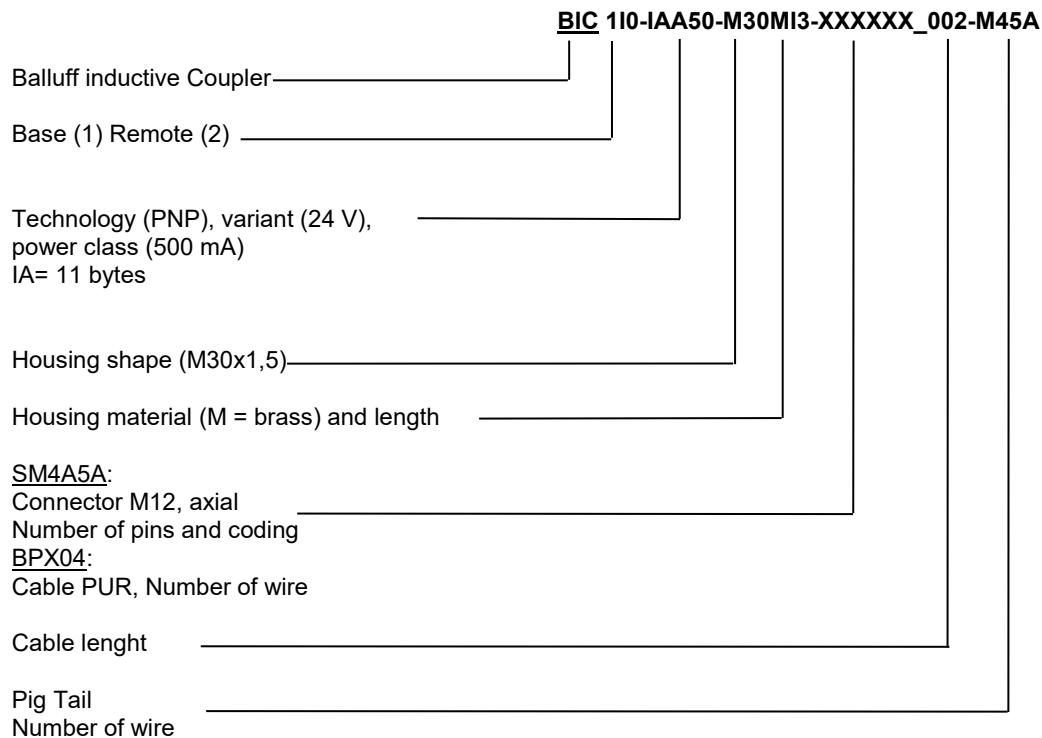

10.2. Order code

Description	Order code
BIC 1I0-IAA50-M30MI3-SM4A4A	BIC0053
BIC 2I0-IAA50-M30MI3-SM4A5A	BIC0054
BIC 2I0-IAA50-M30MI3-BPX04-002-M45A	BIC005H

www.balluff.com

Balluff GmbH
Schurwaldstrasse 9
73765 Neuhausen a.d.F.
Deutschland
Tel.: 07158 173-0
Fax: 07158 5010
balluff@balluff.de

BALLUFF

Nr. 885425-726 E • 04.127519 • Edition L 18 • Replaces Edition 1203 • Subject to modification.