

ifm electronic

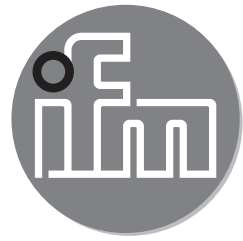

Operating instructions  
Pressure sensor

**efector500<sup>®</sup>**

**PY9920**

**UK**

06/2016

706036/00

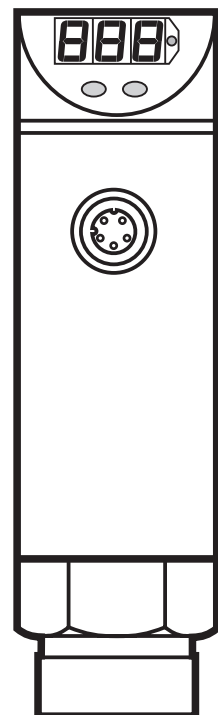

# Contents

1 Safety instructions .....	3
2 Conditions for application .....	3
3 Function and features .....	4
4 Function.....	5
4.1 Switching function.....	5
4 Installation .....	5
6 Electrical connection.....	6
7 Operating and display elements .....	7
8 Menu.....	8
8.1 Menu structure.....	8
8.2 Menu explanation .....	8
9 Parameter setting .....	9
9.1 Parameter setting general .....	9
9.2 Setting the output signal .....	11
9.3 User settings (optional).....	11
9.4 Service functions .....	12
10 Operation.....	13
10.1 Operation indication.....	13
10.2 Read the set parameter values .....	13
10.3 Fault indication .....	13
11 Scale drawing .....	14
12 Technical data.....	15
12.1 Setting ranges .....	16
13 Factory setting.....	16

## Preliminary note

- In these instructions the operating elements are represented as follows:  
[Mode/Enter] = “Mode/Enter” button
- The indications are represented as follows:  
[OU1] = parameter “OU1”, [Hno] = parameter value “Hno”
- An instruction on how to act is indicated by “▶”.  
Example: ▶ Check the reliable functioning of the unit.
- A reaction to the action is indicated by “>”.  
Example: > LED is lit.

UK

## 1 Safety instructions

- **Please read the product description prior to installing the unit.**
- **Ensure that the product is suitable for your application without any restrictions.**
- **If the operating instructions or the technical data are not adhered to, personal injury and/or damage to property may occur.**
- **Please check for all applications that the product materials (see Technical data) are compatible with the media to be measured.**
- **Protect the units and the cables efficiently against damage.**

## 2 Conditions for application

- The sensor is used in nitrogen dampers in pressing machines. It monitors pressure drops caused by leakage (nitrogen leakage).
- The process transducer of the sensor has ventilation holes with an integrated filtering element. The special seal of the measuring cell is designed for nitrogen applications (inert gas).
- The application is limited to the following operating conditions:
  - Operating pressure : 13 ... 24 MPa for measuring cycles of 1100 ms (about 0.9 Hz).
  - Operating temperature: 40°C, max. 70°C.
  - Speed of the pressing machine: 0.5 m/s.
- The mounting of the sensor into a robust metal housing for additional protection of persons (as used at Aioi Seiki) is part of the application.

Additional claims against ifm electronic gmbh in case of incorrect mounting or operation are excluded, especially in the following cases:

- Personal injuries caused by gas leakage due to destruction of individual components.
- Damage caused by modifications of application conditions.
- Damage caused by missing housing protection.
- Changes in the type of mounting and application conditions (especially use of other gases) have to be checked with the sensor manufacturer

### 3 Function and features

The pressure sensor detects the system pressure.

- It shows the current system pressure on its display.
- It generates 1 output signal according to the set output configuration. OUT1 = switching signal for system pressure.

### Applications

Type of pressure: relative pressure

Order no.	Measuring range		Permissible overload pressure		Bursting pressure	
	bar	PSI <sup>1)</sup>	bar	PSI	bar	PSI
PY9920	0...400	0...5 800	600	8 700	1 000	14 500

<sup>1)</sup> For Uni = PSI 1/10 of the PSI value is displayed.

The displayed value must be multiplied by factor 10.

Example: displayed value = 15; real value = 15 \* 10 = 150 PSI.

MPa = bar ÷ 10 / kPa = bar × 100



Static and dynamic overpressures exceeding the indicated overload pressure are to be avoided by taking appropriate measures.

The indicated bursting pressure must not be exceeded. Even if the bursting pressure is exceeded only for a short time, the unit can be destroyed.

NOTE: Risk of injury!

Indication of the current system pressure as from 1% of the value of the measuring range. Display „0“ does not mean that the system is free of pressure!

# 4 Function

## 4.1 Switching function

OUT1 changes its switching state when the set switching limits have not been reached or have been exceeded (SP1, rP1). The following switching functions can be selected:

- hysteresis function / normally open: [OU1] = [Hno] (→ fig. 1).
- hysteresis function / normally closed: [OU1] = [Hnc] (→ fig. 1).

First the set point (SP1) is set, then the reset point (rP1) with the requested difference.

- window function / normally open: [OU1] = [Fno] (→ fig. 2).
- window function / normally closed: [OU1] = [Fnc] (→ fig. 2).

The width of the window can be set by means of the difference between SP2 and rP2. SP2 = upper value, rP2 = lower value.

UK

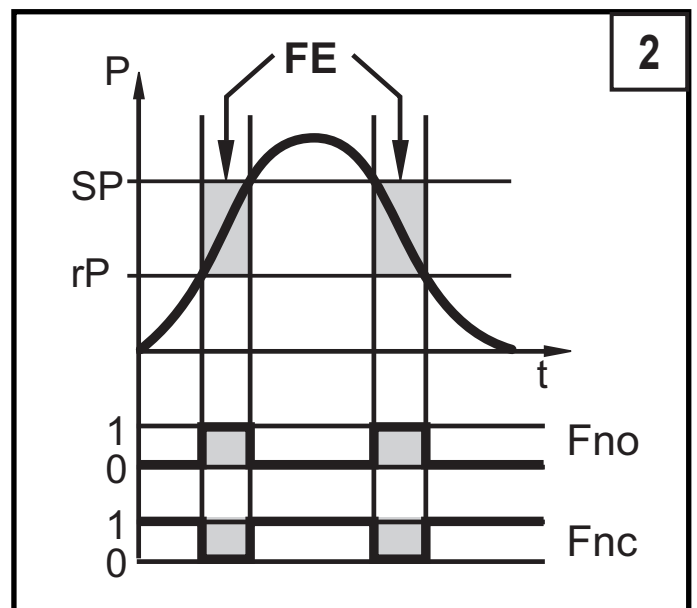
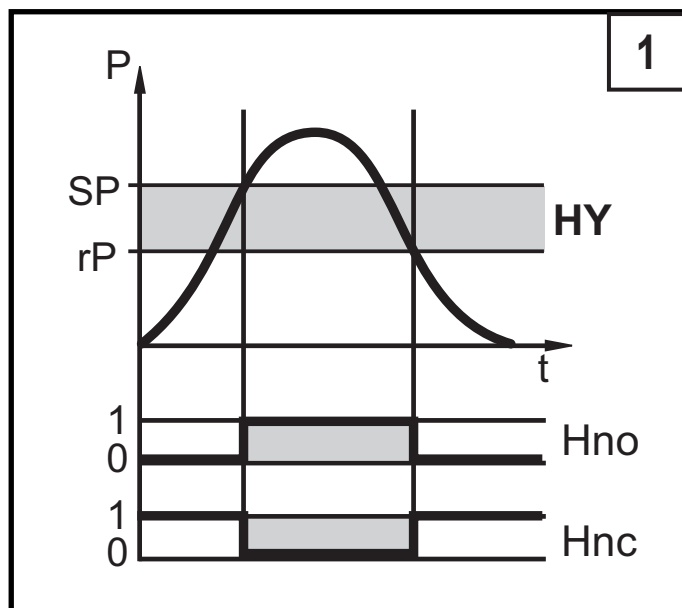

P = system pressure; HY = hysteresis; FE = window (acceptable range)

## 4 Installation



Before mounting and removing the sensor, make sure that no pressure is applied to the system.

- ▶ Insert the unit in a G $\frac{1}{4}$  process connection.
- ▶ Tighten firmly.

## 6 Electrical connection



The unit must only be connected by an electrician.

The national and international regulations for the installation of electrical equipment must be observed.

Caution: For the output circuit the same protective measures as for the supply circuit must be taken.

Insert a miniature fuse according to IEC60127-2 Sheet 1 ( $\leq 5$  A fast acting).

The permissible potential difference between supply and output circuit is max. 300 V.

- ▶ Disconnect power.
- ▶ Connect the unit as follows:

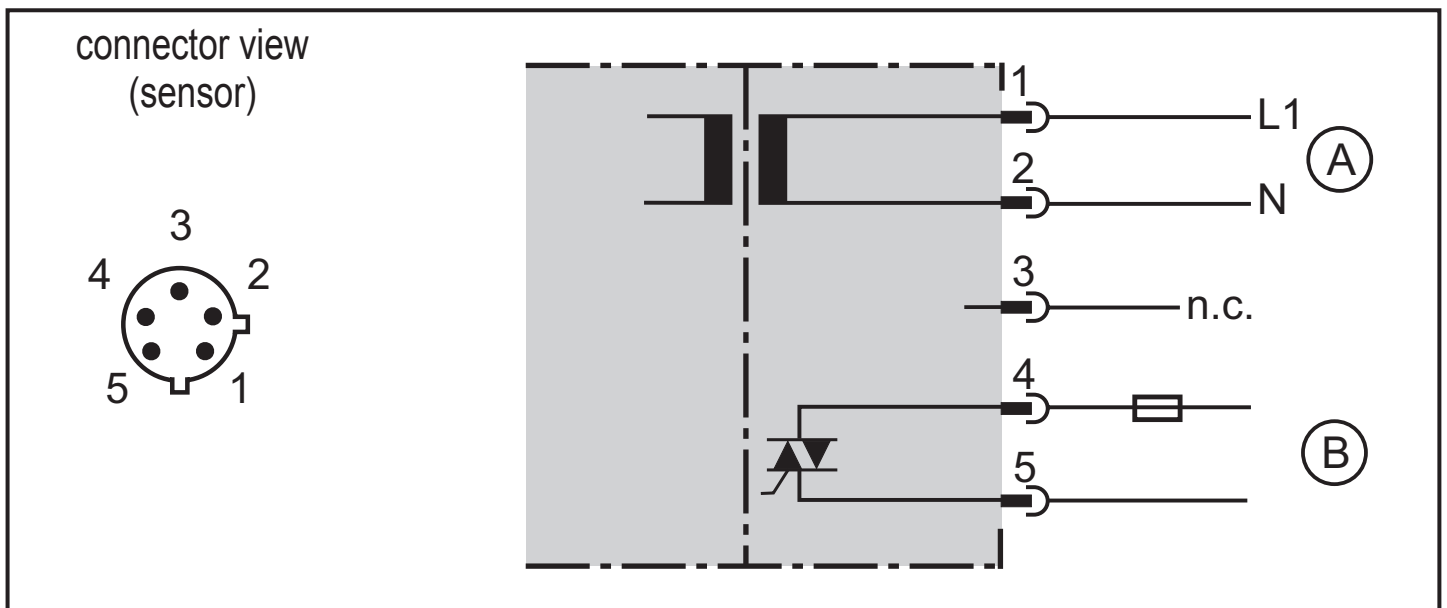

A: supply circuit

B: output circuit

— · — · — · — : safe separation

## 7 Operating and display elements

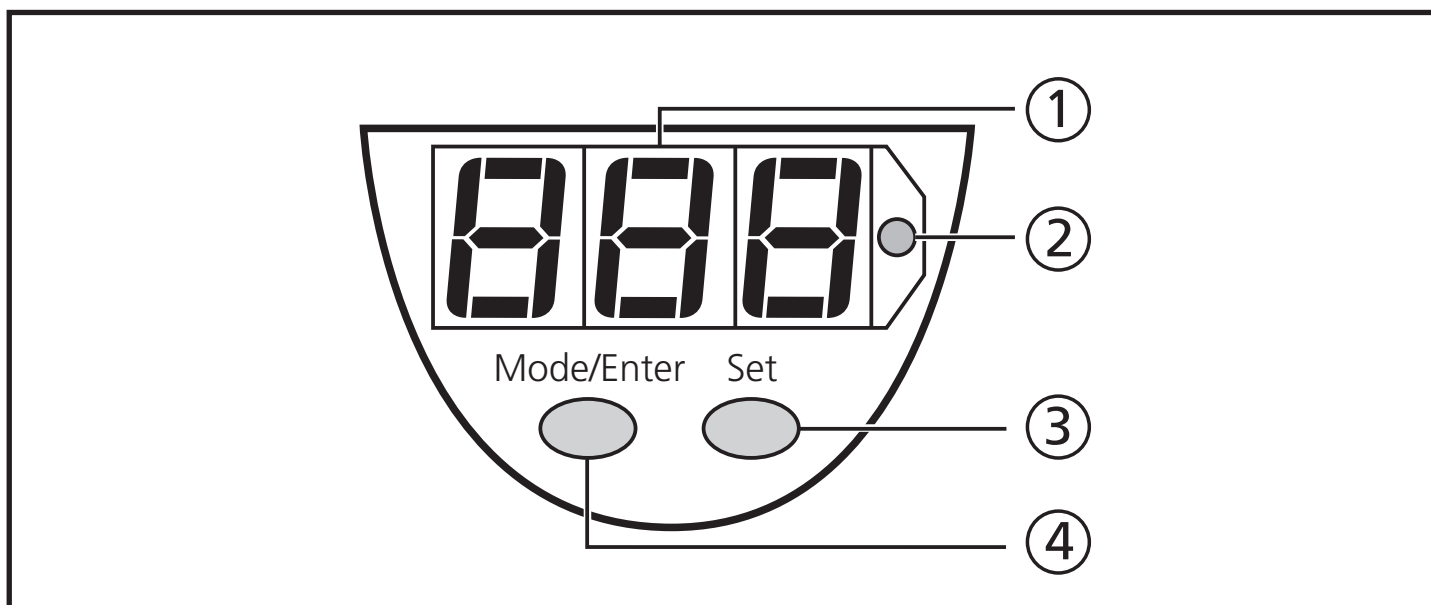

UK

### 1: LED display

- Display of the system pressure<sup>1)</sup>.
- Display of parameters and parameter values.

### 2: LED red

Indication of the switching status; lights if the output has switched.

### 3: Set pushbutton

- Setting of the parameter values (scrolling by holding pressed, incremental by pressing briefly).

### 4: Mode/Enter pushbutton

- Selection of the parameters and acknowledgement of the parameter values.

<sup>1)</sup> PSI value = displayed value × 10

# 8 Menu

## 8.1 Menu structure

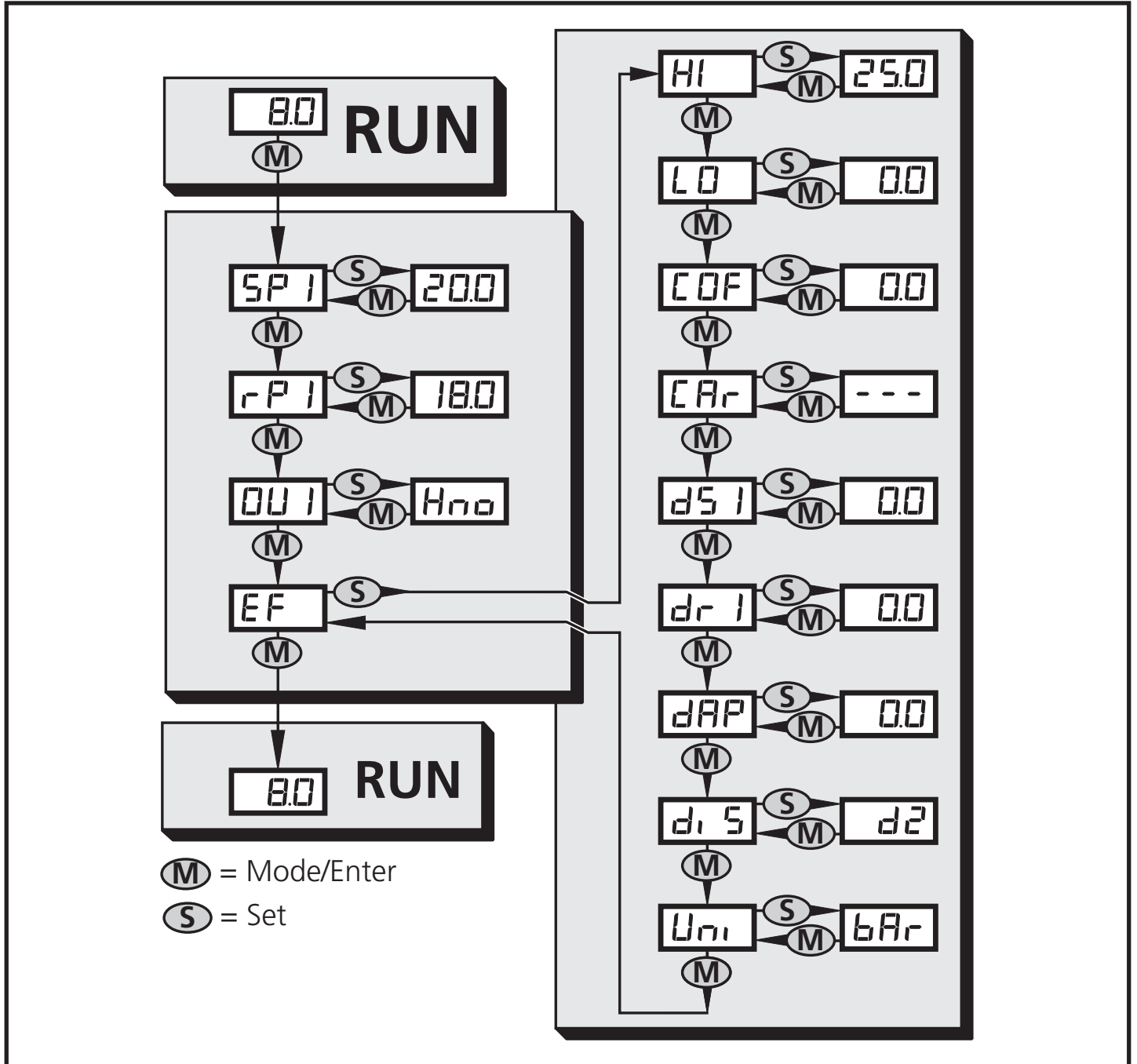

## 8.2 Menu explanation

SP1/rP1	Upper / lower limit value for the system pressure at which output 1 changes its switching status.
OU1	Output function for OUT1: <ul style="list-style-type: none"> <li>Switching signal for the limit values: hysteresis function [H ..] or window function [F ..], normally open [. no] or normally closed [. nc] each.</li> </ul>
EF	Extended functions / Opening menu level 2.
HI / LO	Maximum / minimum value memory for the system pressure.
COF	Zero point calibration.



CAr	Calibration reset.
dS1 / dr1	Switch-on delay / reset delay for für OUT1.
dAP	Damping for OUT1.
diS	Update rate and orientation of the display.
Uni	Standard unit of measurement for the system pressure.

## 9 Parameter setting

During the parameter setting process the unit remains in the operating mode. It continues its monitoring function with the existing parameters until parameter setting has been terminated.

UK

### 9.1 Parameter setting general

Each parameter setting requires 3 steps:

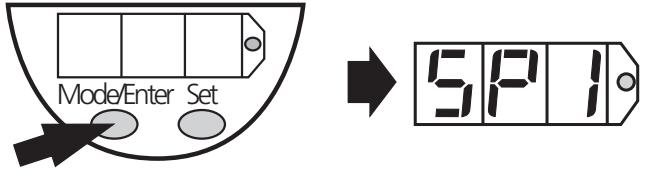
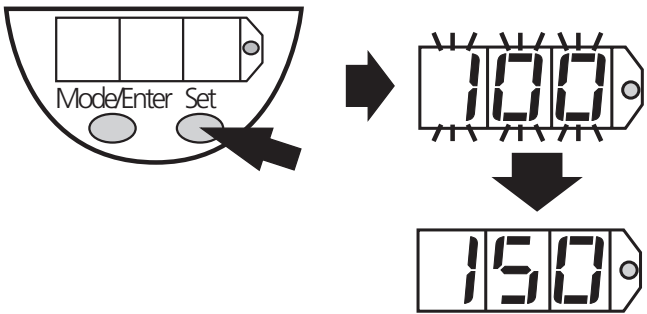
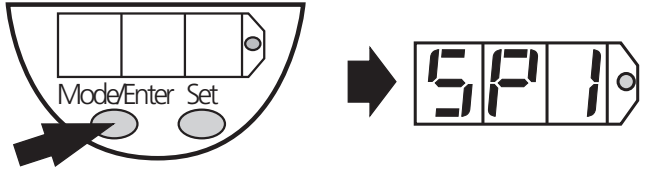
<b>1</b>	<p><b>Selecting parameter</b></p> <ul style="list-style-type: none"> <li>▶ Press [Mode/Enter] until the requested parameter is displayed</li> </ul>	
<b>2</b>	<p><b>Setting the parameter value</b></p> <ul style="list-style-type: none"> <li>▶ Press [Set] and keep the button pressed.</li> <li>&gt; Current setting value of the parameter bit flashes for 5 s.</li> <li>&gt; After 5 s: Setting value is changed: incremental by pressing briefly or scrolling by holding pressed.</li> </ul>	
<p>The numerical values are incremented continuously. If the value is to be reduced: Let the display move to the maximum setting value. Then the cycle starts again at the minimum setting value.</p>		
<b>3</b>	<p><b>Acknowledge parameter value</b></p> <ul style="list-style-type: none"> <li>▶ Press [Mode/Enter] briefly.</li> <li>&gt; The parameter is displayed again. The new setting value is stored.</li> </ul>	
<p><b>Set more parameters:</b></p> <ul style="list-style-type: none"> <li>▶ Start again with step 1.</li> </ul>		
<p><b>Finishing parameter setting:</b></p> <ul style="list-style-type: none"> <li>▶ Press [Mode/Enter] several times until the current measured value is displayed or wait for 15 s. The unit returns to the operating mode if no button is pressed for over 15 s after acknowledgement of the new parameter value.</li> </ul>		

- Changing from menu level 1 to menu level 2:

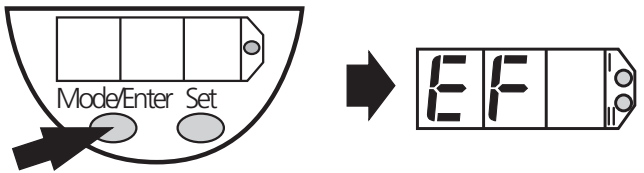
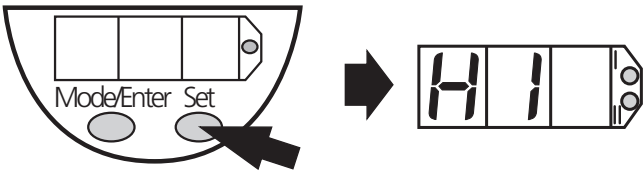
<ul style="list-style-type: none"> <li>▶ Press [Mode/Enter] until [EF] is displayed.</li> </ul>	
<ul style="list-style-type: none"> <li>▶ Press [Set] briefly.</li> <li>&gt; The first parameter of the submenu is displayed (here: [HI]).</li> </ul>	

- Locking / unlocking

The unit can be locked electronically to prevent unintentional wrong settings.

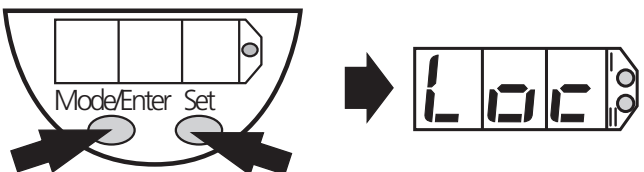
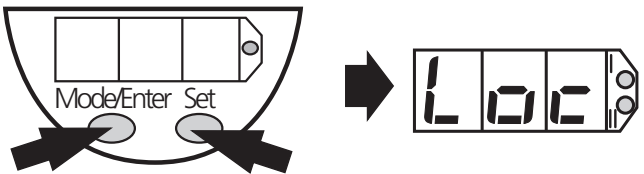
<ul style="list-style-type: none"> <li>▶ Ensure that the unit is in the normal operating mode.</li> <li>▶ Press [Mode/Enter] + [Set] for 10 s.</li> <li>&gt; [Loc] is displayed.</li> </ul>	
<p>During operation: &gt; [Loc] is displayed briefly when you try to change parameter values.</p>	
<p>For unlocking:</p> <ul style="list-style-type: none"> <li>▶ Press [Mode/Enter] + [Set] for 10 s.</li> <li>&gt; [Loc] is displayed.</li> </ul>	

On delivery: Unlocked.

- Timeout:

If no button is pressed for 15 s while the parameters are being set, the unit returns to the operating mode with unchanged values.

## 9.2 Setting the output signal

<b>9.2.1 Setting the switching limits</b>	
▶ Select [SP1] and set the value at which the output switches.	SP1
▶ Select [rP1] and set the value at which the output switches back. rP1 is always lower than SP1. The unit only accepts values which are lower than SP1.	rP1
<b>9.2.2 Setting the output function</b>	
▶ Select [OU1] and set the switching function: [Hno] = hysteresis function / normally open, [Hnc] = hysteresis function / normally closed, [Fno] = window function / normally open, [Fnc] = window function / normally closed.	OU1

UK

## 9.3 User settings (optional)

<b>9.3.1 Setting the unit of measurement for the system pressure</b>	
▶ Select [Uni] and set the unit of measurement: [bAr] (= bar), [PA] (= MPa) or [PSI]. For Uni = PSI 1/10 of the PSI value is displayed. The displayed value must be multiplied by factor 10. Example: displayed value = 15; real value = 15 * 10 = 150 PSI. Labels for the different units of display are enclosed with the unit. Stick the respective label on the sensor or fill in the blank label.	Uni
<b>9.3.2 Configuring the display</b>	
▶ Select [diS] and set update rate and orientation of the display: [d1]: Update of the measured value every 50 ms. [d2]: Update of the measured value every 200 ms. [d3]: Update of the measured value every 600 ms. [Ph]: Display of the measured peak value remains for a short time (peak hold). [rd1], [rd2], [rd3], [Ph]: Display like d1, d2, d3, Ph; rotated by 180°. [OFF]: The display is deactivated in the operating mode.	diS

<b>9.3.3 Zero-point calibration</b>	
<ul style="list-style-type: none"> <li>▶ Select [COF] and set a value between -5% and 5% of the final value of the measuring range. The internal measured value "0" is shifted by this amount.</li> </ul>	COF
<p>Resets the calibration set by COF to the value set at the factory.</p> <ul style="list-style-type: none"> <li>▶ Press [Mode/Enter] until [CAr] is displayed.</li> <li>▶ Press [Set] and keep it pressed until [---] is displayed.</li> <li>▶ Press [Mode/Enter] briefly.</li> </ul>	CAr
<b>9.3.4 Setting the delay time for OUT1</b>	
<p>[dS1] = switch-on delay for OUT1. [dr1] = switch-off delay for OUT1.</p> <ul style="list-style-type: none"> <li>▶ Select [dS1] or [dr1], set value between 0.1 und 50 s (at 0.0 the delay time is not active).</li> </ul>	dS1 dr1
<b>9.3.5 Setting the damping for OUT1</b>	
<ul style="list-style-type: none"> <li>▶ Select [dAP], set value between 0.01 ... 4.00 s; (at 0.00 [dAP] time is not active).</li> </ul> <p>dAP-value = response time between pressure change and change of the switching status in seconds (s). Correlation between switching frequency and [dAP]: <math>f_{\max} = 1 \div 2dAP</math>.</p>	dAP

## 9.4 Service functions

<b>9.4.1 Reading the min./max. values for the system pressure</b>	
<ul style="list-style-type: none"> <li>▶ Select [HI] or [LO], press [Set] briefly. [HI] = maximum value, [LO] = minimum value.</li> </ul> <p>Delete memory:</p> <ul style="list-style-type: none"> <li>▶ Select [HI] or [LO].</li> <li>▶ Press [Set] until [---] is displayed.</li> <li>▶ Press [Mode/Enter] briefly.</li> </ul>	HI LO

## 10 Operation

After power on of the supply voltage the unit is in the Run mode (= normal operation). It carries out its measurement and evaluation functions and generates output signals according to the set parameters.

### 10.1 Operation indication

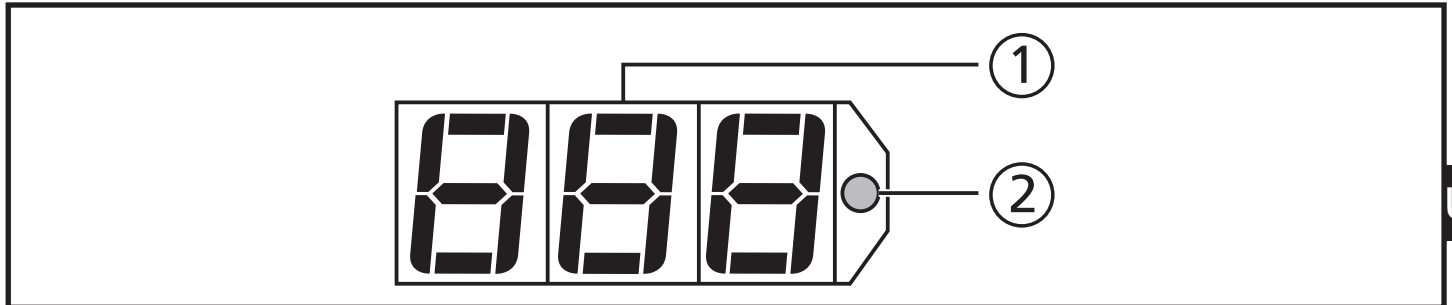

UK

1	Current system pressure in bar, MPa, PSI. PSI value = displayed value × 10.
2	Switching status of OUT1.

### 10.2 Read the set parameter values

- ▶ Press [Mode/Enter] briefly to scroll the parameters.
- ▶ Press [Set] briefly to indicate the corresponding parameter value for 15 s. After another 15 s the unit returns to the Run mode.

### 10.3 Fault indication

[OL]	overload pressure (measuring range exceeded)
[UL]	underpressure range (measuring range below the minimum value)

# 11 Scale drawing

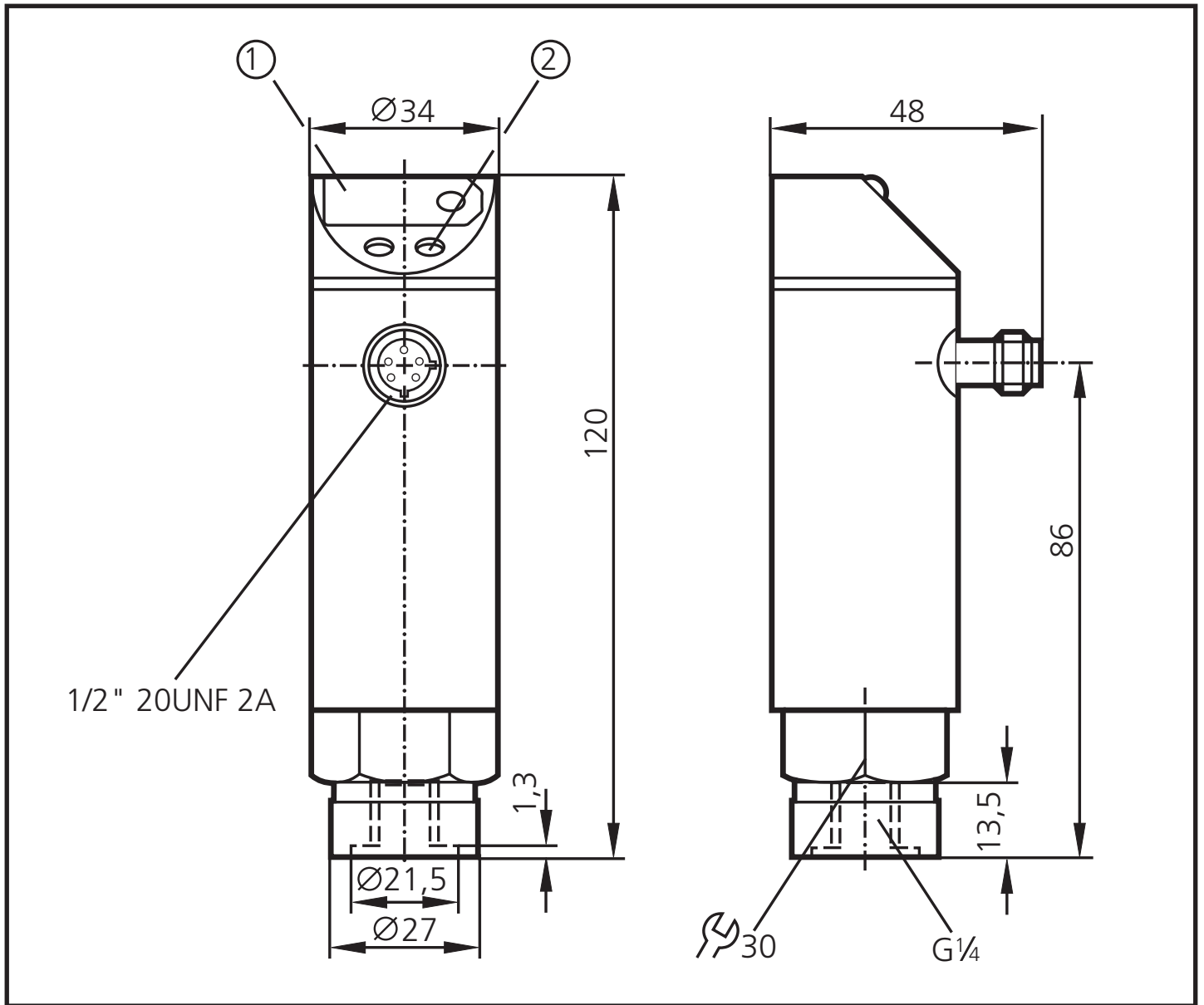

1: Display; 2: programming button

## 12 Technical data

Nominal voltage [V] .....	90 ... 240 AC (45...65 Hz)
Voltage tolerance [%].....	-5 / +10
Operating voltage [V].....	85 ... 265 AC
Current rating [A] .....	2.5 (20°C), 1.5 (45°C), 1 (60°C), 0.25 (70°C) shortly (< 200 ms) 15 A (+20°C); 6 A (+60°C)
Integrated Watchdog	
Voltage drop [V] .....	< 2
Current consumption [mA] .....	< 10
Power-on delay time [s] .....	0.2
Accuracy / deviations (in% of the span)	
- switch point .....	< ± 1.0
- linearity .....	< ± 0.5
- hysteresis .....	< ± 0.1
- repeatability (with temperature fluctuations < 10K).....	< ± 0.1
Long-time stability (in% of the span per year).....	< ± 0.1
Temperature coefficients (TEMPCO) in the compensated temperature range 0 ... +80°C (in% of the span per 10 K)	
- greatest TEMPCO of the zero point / of the span .....	< ± 0.2 / < ± 0.3
Materials (wetted parts) .....	stainless steel (303S22); ceramics; FKM
Housing material .....	stainless steel (304S15); PC (Macrolon); PBT (Pocan); PA; FPM (Viton); EPDM/X (Santoprene)
Protection / Protection class .....	IP 67 II (PN4220- PN4222)
Insulation resistance [MΩ].....	> 100 (500 V DC)
Shock resistance [g] .....	50 (DIN / IEC 68-2-27, 11ms)
Vibration resistance [g] .....	20 (DIN / IEC 68-2-6, 10 - 2000 Hz)
Switching cycles min. ....	100 million
Operating temperature [°C] .....	-25 ... +80
Medium temperature [°C] .....	-25 ... +80
Storage temperature [°C].....	-40 ... +100
EMC EN 61000-4-2 ESD: .....	4 / 8 KV
EN 61000-4-3 HF radiated: .....	10 V/m
EN 61000-4-4 Burst: .....	2 KV
EN 61000-4-6 HF conducted: .....	10 V

Information to cULus approval:

- enclosure type 1
- ambient temperature 0...40°C
- for use in Pollution Degree 2 Environment

UK

## 12.1 Setting ranges

		SP1		rP1		$\Delta P$
		min	max	min	max	
<b>PY9920</b>	bar	4	400	2	398	1
	PSI * 10	6	580	3	577	1
	MPa	0.4	40.0	0.2	39.8	0.1

$\Delta P$  = increments

## 13 Factory setting

	Factory setting	User setting
<b>SP1</b>	<b>25% VMR</b>	
<b>rP1</b>	<b>23% VMR</b>	
<b>OU1</b>	<b>Hno</b>	
<b>COF</b>	<b>0.0</b>	
<b>dS1</b>	<b>0.0</b>	
<b>dr1</b>	<b>0.0</b>	
<b>dAP</b>	<b>0.06</b>	
<b>diS</b>	<b>d2</b>	
<b>Uni</b>	<b>bAr</b>	

VMR = final value of the measuring range

More information at [www.ifm.com](http://www.ifm.com)



