



CE

Operating instructions
Pressure sensor
PQ08xx

UK

06 / 2019

11450561 / 00

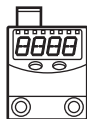

Contents

| | | |
|-------|---|----|
| 1 | Preliminary note..... | 3 |
| 1.1 | Symbols used..... | 3 |
| 2 | Safety instructions..... | 3 |
| 3 | Functions and features..... | 4 |
| 4 | Function..... | 5 |
| 4.1 | Processing of the measured signals..... | 5 |
| 4.2 | Switching function..... | 5 |
| 4.3 | Diagnostic function..... | 6 |
| 5 | Mounting..... | 6 |
| 5.1 | Mounting accessories..... | 6 |
| 5.2 | DIN rail mounting..... | 7 |
| 5.3 | Rear panel mounting..... | 7 |
| 6 | Electrical connection..... | 8 |
| 7 | Operating and display elements..... | 9 |
| 8 | Menu..... | 10 |
| 8.1 | Menu structure..... | 10 |
| 8.2 | Explanation of the menu..... | 11 |
| 9 | Parameter setting..... | 12 |
| 9.1 | General parameter setting..... | 12 |
| 9.2 | Setting of the output signals..... | 14 |
| 9.2.1 | Setting of the unit of measurement for system pressure..... | 14 |
| 9.2.2 | Setting of the output function..... | 14 |
| 9.2.3 | Setting of the switching limits (hysteresis function)..... | 14 |
| 9.2.4 | Setting of the switching limits (window function)..... | 14 |
| 9.3 | User settings (optional)..... | 15 |
| 9.3.1 | Setting of a time delay for the switching signals..... | 15 |
| 9.3.2 | Setting of the damping for the switching outputs..... | 15 |
| 9.3.3 | Configuration of the display..... | 15 |
| 9.3.4 | Zero point calibration..... | 16 |
| 9.4 | Service functions..... | 16 |
| 9.4.1 | Reading of the min/max values for system pressure..... | 16 |
| 9.4.2 | Reset of all parameters to factory setting..... | 16 |

| | |
|--|----|
| 10 Operation..... | 17 |
| 10.1 Reading of the set parameters | 17 |
| 10.2 Fault indication | 17 |
| 10.3 Setting ranges | 17 |
| 11 Werkseinstellung..... | 18 |

1 Preliminary note

1.1 Symbols used

- ▶ Instruction
- > Reaction, result
- [...] Designation of pushbuttons, buttons or indications
- Cross-reference



Important note:

Non-compliance can result in malfunctions or interference.

2 Safety instructions

- The device described is a subcomponent for integration into a system.
 - The manufacturer of the system is responsible for the safety of the system.
 - The system manufacturer undertakes to perform a risk assessment and to create a documentation in accordance with legal and normative requirements to be provided to the operator and user of the system. This documentation must contain all necessary information and safety instructions for the operator, the user and, if applicable, for any service personnel authorised by the manufacturer of the system.
- Read this document before setting up the product and keep it during the entire service life.
- The product must be suitable for the corresponding applications and environmental conditions without any restrictions.
- Only use the product for its intended purpose (→ Functions and features).
- Only use the product for permissible media (→ Technical data).
- If the operating instructions or the technical data are not adhered to, personal injury and/or damage to property may occur.

- The manufacturer assumes no liability or warranty for any consequences caused by tampering with the product or incorrect use by the operator.
- Installation, electrical connection, set-up, operation and maintenance of the unit must be carried out by qualified personnel authorised by the machine operator.
- Protect units and cables against damage.

For the scope of validity cULus:

The device shall be supplied from an isolating transformer having a secondary Listed fuse rated either

- max 5 amps for voltages 0~20 Vrms (0~28.3 Vp) or
- 100/Vp for voltages of 20~30 Vrms (28.3~42.4 Vp).

The Sensor shall be connected only by using any R/C (CYJV2) cord, having suitable ratings.

3 Functions and features

The unit monitors the system pressure in pneumatic and compressed air networks of machines and plants.

Applications

Compressed air (other media on request)

Type of pressure: relative pressure

| Order no. | Measuring range | | Permissible overpressure | | Bursting pressure | |
|-----------|-----------------|--------------|--------------------------|-----|-------------------|-----|
| | bar | PSI | bar | PSI | bar | PSI |
| PQ0809 | -1...1 | -14.6...14.5 | 20 | 290 | 30 | 435 |
| PQ0834 | -1...10 | -15...145 | 20 | 290 | 30 | 435 |

$$\text{MPa} = \text{bar} \div 10 \quad / \quad \text{kPa} = \text{bar} \times 100$$



Avoid static and dynamic overpressure exceeding the given overload pressure by taking appropriate measures.

The indicated bursting pressure must not be exceeded.

Even if the bursting pressure is exceeded only for a short time, the unit may be destroyed. NOTE: Risk of injury!

4 Function

4.1 Processing of the measured signals

- The unit displays the current system pressure.
- It generates 2 output signals according to the parameter setting.

| | |
|-------------|--|
| OUT1 | • Switching signal for system pressure limit value. |
| OUT2 | 2 options • Switching signal for system pressure limit value. • Diagnostic signal (output 1 is inactive in case of a fault). |

4.2 Switching function

OUTx changes its switching state if it is above or below the set switching limits (SPx, rPx). The following switching functions can be selected:

- Hysteresis function / normally open: [oux] = [Hno] (→ fig. 1).
- Hysteresis function / normally closed: [oux] = [Hnc] (→ fig. 1).

First the set point (SPx) is set, then the reset point (rPx) with the requested difference.

- Window function / normally open: [oux] = [Fno] (→ fig. 2).
- Window function / normally closed: [oux] = [Fnc] (→ fig. 2).

The width of the window can be set by means of the difference between FHx and FLx. FHx = upper value, FLx = lower value.

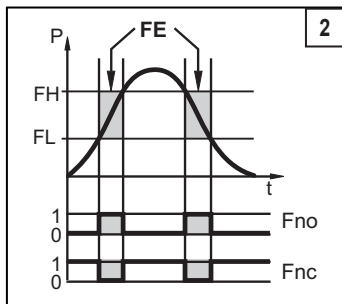
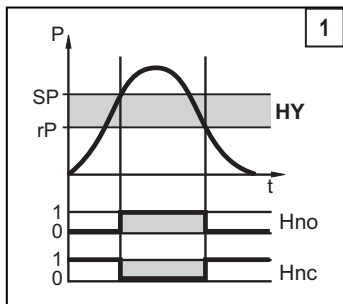

P = system pressure; HY = hysteresis; FE = window

4.3 Diagnostic function

Output 2 is used as diagnostic output based on the DESINA specification if [ou2] = [diA].

- If there is no fault, the output is switched and carries U_b .
- In case of malfunctions in the following areas, the output is inactive:
 - short circuit in output 1.
 - EPROM function.
 - RAM function.
 - parameter setting.
 - processor function.

5 Mounting



Before installing and removing the unit: make sure that no pressure is applied to the system.

- ▶ Screw the pressure connection or adapter $G\frac{1}{8}$ to the main pressure connection (1) and tighten.

Maximum tightening torque: 8 Nm.

Maximum thread length: 7.5 mm.

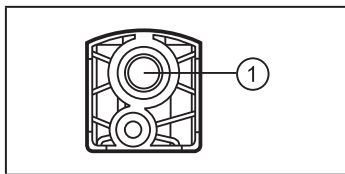

5.1 Mounting accessories

The following components are available as accessories:

| | Order no. |
|---|-----------|
| Mounting set for DIN rail mounting (DIN rail TH 35-7.5 to EN 60715) | E37340 |
| Thread extension 1/8" for flange mounting | E30075 |
| Push-in air fitting for tube \varnothing 6 mm | E30076 |
| Push-in air fitting for tube \varnothing 8 mm | E30077 |

5.2 DIN rail mounting

DIN rail TH 35-7.5 to EN 60715

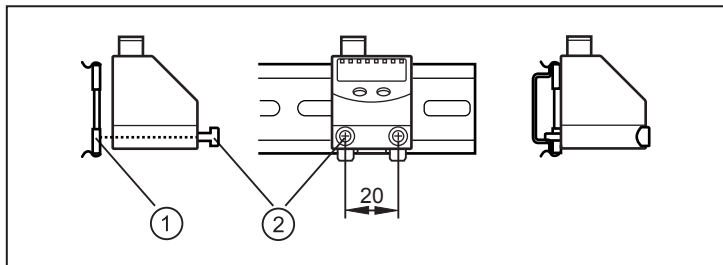

- ▶ Fix the mounting clip (1) with the screws M4 x 35 (2) to the flange. Maximum tightening torque: 0.5 Nm.
- ▶ Hook the unit into the DIN rail and clip it into place.

Removal:

- ▶ Lever out the mounting clip with a screwdriver at the top or at the bottom and remove the unit.

5.3 Rear panel mounting

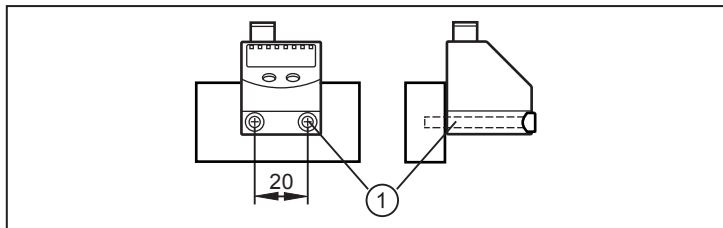

- ▶ Fix the unit with 2 screws M4 x 35 (1) (not included) to the rear panel. Maximum tightening torque: 0,5 Nm.

6 Electrical connection



The unit must be connected by a qualified electrician.

The national and international regulations for the installation of electrical equipment must be adhered to.

Voltage supply to SELV, PELV.

- ▶ Disconnect power.
- ▶ Connect the unit as follows:

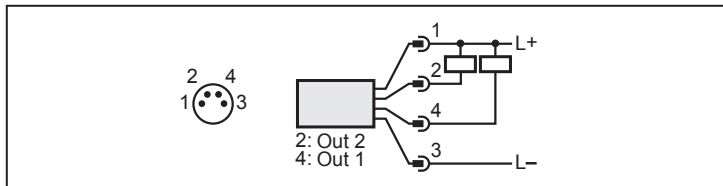

| | |
|---------------------|---|
| Pin 1 | Ub+ |
| Pin 3 | Ub- |
| Pin 4 (OUT1) | • binary switching output pressure monitoring |
| Pin 2 (OUT2) | • binary switching output if [ou2] = [Hno], [Hnc], [Fno] or [Fnc] • diagnostic output if [ou2] = [diA] |

7 Operating and display elements

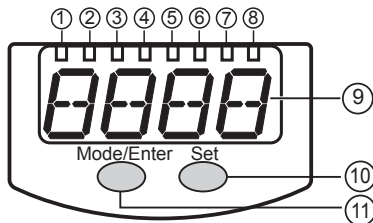

1 to 8: Indicator LEDs

- LED 1 to LED 4 = system pressure in the unit of measurement which is indicated on the label.
- LEDs 5 to 6: not used,
- LED 7, LED 8 = switching state of the corresponding output.

9: Alphanumeric display, 4 digits

- Indication of the current system pressure.
- Indication of the parameters and parameter values.

10: Set button

- Setting of the parameter values (scrolling by holding pressed; incrementally by pressing once).

11: Mode/Enter button

- Selection of the parameters and acknowledgement of the parameter values

8 Menu

8.1 Menu structure

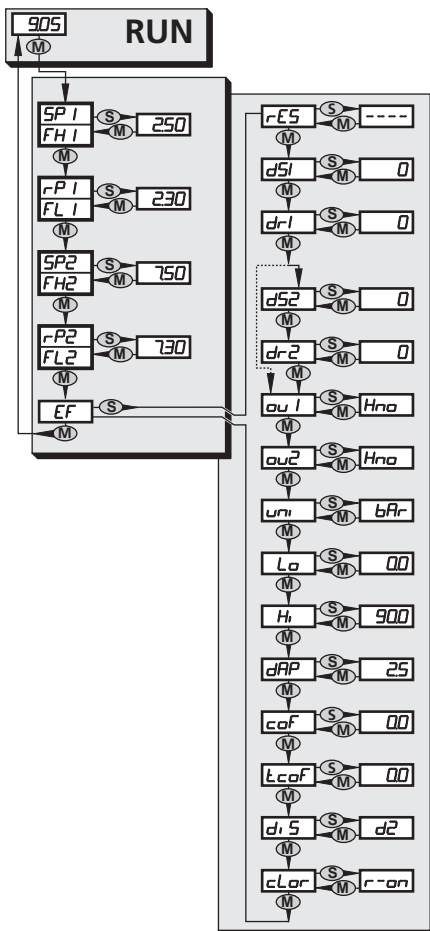

8.2 Explanation of the menu

| | |
|---------|--|
| SP1/rP1 | Upper / lower limit value for system pressure at which OUT1 switches. |
| FH1/FL1 | Upper / lower limit for the acceptable range (monitored by OUT1). |
| SP2/rP2 | Upper / lower limit value for system pressure at which OUT2 switches. |
| FH2/FL2 | Upper / lower limit for the acceptable range (monitored by OUT2). |
| EF | Extended functions / opening of menu level 2. |
| rES | Restore factory settings. |
| dS1 | Time delay for SP1 / FH1. |
| dS2 | Time delay for SP2 / FH2. |
| dr1 | Time delay for rP1 / FL1. |
| dr2 | Time delay for rP2 / FL2. |
| ou1 | Output function for OUT1: <ul style="list-style-type: none"> Switching signal for the pressure limit values: hysteresis function [H ..] or window function [F ..], either normally open [. no] or normally closed [. nc]. |
| ou2 | Output function for OUT2: <ul style="list-style-type: none"> Switching signal for the pressure limit values: hysteresis function [H ..] or window function [F ..], either normally open [. no] or normally closed [. nc]. Diagnostic signal [ou2] = diA. |
| uni | Standard unit of measurement for system pressure. |
| Lo | Maximum value memory for system pressure. |
| Hi | Minimum value memory for system pressure. |
| dAP | Damping for the switching outputs. |
| coF | Manually enter the zero point calibration. |
| tcoF | Teach zero-point calibration. |
| diS | Update rate and orientation of the display. |
| cLor | Colour of the digital display (permanent or alternating with switching status OUT1). |



UK

9 Parameter setting

During parameter setting the unit remains in the operating mode. It continues its monitoring function with the existing parameters until the parameter setting has been completed.

9.1 General parameter setting

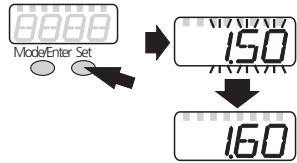
3 steps must be taken for each parameter setting:

| | | |
|--|---|---|
| 1 | Parameter selection ▶ Press [Mode/Enter] until the requested parameter is displayed. |  |
| 2 | Setting of the parameter value ▶ Press [Set] and keep it pressed. > Current setting value of the parameter flashes for 5 s. > After 5 s: setting value is changed: incrementally by pressing the button once or continuously by keeping the button pressed. |  |
| Numerical values are incremented continuously. To reduce the value: let the display move to the maximum setting value. Then the cycle starts again at the minimum setting value. | | |
| 3 | Acknowledgement of the parameter value ▶ Press [Mode/Enter] briefly. > The parameter is displayed again. The new setting value is stored. |  |
| Setting of other parameters: ▶ Start again with step 1. | | |
| Finishing the parameter setting: ▶ Press [Mode/Enter] several times until the current measured value is displayed or wait for 15 s. > The unit returns to the operating mode. | | |

- Change from menu level 1 to menu level 2:

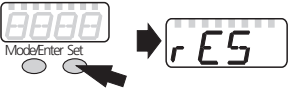
| | |
|---|---|
| <p>▶ Press [Mode/Enter] until [EF] is displayed.</p> <p>If the submenu is protected with an access code, "Cod1" flashes in the display.</p> <p>▶ Press [Set] and keep it pressed until the valid code no. is displayed.</p> <p>▶ Press [Mode/Enter] briefly.</p> <p>On delivery by ifm electronic: no access restriction.</p> |  |
| <p>▶ Press [Set] briefly.</p> <p>> The first parameter of the sub-menu is displayed (here: [uni]).</p> |  |

UK

- Locking / unlocking

The unit can be locked electronically to prevent unintentional settings.

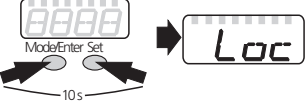
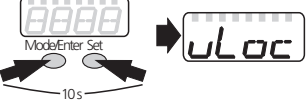
| | |
|---|---|
| <p>▶ Make sure that the unit is in the normal operating mode.</p> <p>▶ Press [Mode/Enter] + [Set] for 10 s.</p> <p>> [Loc] is displayed.</p> |  |
| <p>During operation: [Loc] is briefly displayed if you try to change parameter values.</p> | |
| <p>For unlocking:</p> <p>▶ Press [Mode/Enter] + [Set] for 10 s.</p> <p>> [uLoc] is displayed.</p> |  |

On delivery: unlocked.

- Timeout:

If no button is pressed for 15 s during parameter setting, the unit returns to the operating mode with unchanged values.

9.2 Setting of the output signals

9.2.1 Setting of the unit of measurement for system pressure

| | |
|---|------------|
| ▶ Select [uni] and set the unit of measurement: [bAr], [kPa], [PSI], [inHg]. | <i>uni</i> |
|---|------------|

9.2.2 Setting of the output function

| | |
|--|-------------|
| ▶ Select [ou1] and set the function: - [Hno] = hysteresis function / normally open - [Hnc] = hysteresis function / normally closed, - [Fno] = window function / normally open, - [Fnc] = window function / normally closed. | <i>ou 1</i> |
| ▶ Select [ou2] and set the function: - [Hno] = hysteresis function / normally open, - [Hnc] = hysteresis function / normally closed, - [Fno] = window function / normally open, - [Fnc] = window function / normally closed, - [diA] = output 2 is used as a diagnostic output. | <i>ou2</i> |

9.2.3 Setting of the switching limits (hysteresis function)

| | |
|--|----------------------------|
| ▶ Make sure that the function [Hno] or [Hnc] is set for [ou1] or [ou2]. ▶ Select [SP1] / [SP2] and set the value at which the output switches. | <i>SP 1</i> <i>SP 2</i> |
| ▶ Select [rP1] / [rP2] and set the value at which the output switches off. rPx is always smaller than SPx. The unit only accepts values which are lower than the value for SPx. | <i>rP 1</i> <i>rP 2</i> |

9.2.4 Setting of the switching limits (window function)

| | |
|---|----------------------------|
| ▶ Make sure that the function [Fno] or [Fnc] is set for [ou1] or [ou2]. ▶ Select [FH1] / [FH2] and set the upper limit of the acceptable range. | <i>FH 1</i> <i>FH 2</i> |
| ▶ Select [FL1] / [FL2] and set the lower limit of the acceptable range. FLx is always lower than FHx. The unit only accepts values which are lower than FHx. | <i>FL 1</i> <i>FL 2</i> |

9.3 User settings (optional)

9.3.1 Setting of a time delay for the switching signals

- [dS1] / [dS2] = time delay for SP1 / SP2 / FH1 / FH2. If the system pressure exceeds SPx or if the system pressure enters the acceptable range (window), the output changes the switching status when the time dSx has elapsed.
 - [dr1] / [dr2] = time delay for rP1 / rP2 / FL1 / FL2. If the system pressure falls below rPx or if the system pressure leaves the acceptable range (window), the output changes the switching status when the time drx has elapsed.
- ▶ Select [dS1], [dS2], [dr1] or [dr2] and set the value between 0 and 5000 ms in steps of 2 ms (at 0 the time delay is not active).

dS1
dS2
dr1
dr2

UK

9.3.2 Setting of the damping for the switching outputs

- ▶ Select [dAP] and set a value.
dAP value = response time between pressure change and change of the switching status in milliseconds.
The following fix values can be set; they define the switching frequency (f) of the output:

| | | | | | | | | | | |
|-----|-----|-----|----|----|----|-----|-----|-----|------|------|
| dAP | 2.5 | 5 | 10 | 30 | 60 | 100 | 250 | 500 | 1000 | 2000 |
| f | 200 | 100 | 50 | 16 | 8 | 5 | 2 | 1 | 0.5 | 0.25 |

dAP

9.3.3 Configuration of the display

- ▶ Select [diS] and set the update rate and orientation of the display:
- [d1]: update of the measured values every 50 ms.
 - [d2]: update of the measured values every 200 ms.
 - [d3]: update of the measured values every 600 ms.
 - [Ph]: Display of the measured peak value remains for a short time (peak hold).
 - [rd1], [rd2], [rd3], [rPH]: display as for d1, d2, d3; rotated by 180°.
 - [OFF]: the display is switched off in the operating mode.

d1 5

- ▶ Select [cLor] and define the colour of the digital display.
- [r-on]: display = red if output 1 is switched; display = green if output 1 is not switched.
 - [G-on]: display = green if output 1 is switched; display = red if output 1 is not switched.
 - [red]: the colour of the display is red / does not change.
 - [Gren]: the colour of the display is green / does not change.

cLor

9.3.4 Zero point calibration

| | |
|---|-------------|
| <ul style="list-style-type: none">▶ Select [coF] and set a value between -5 % and 5 % of the measuring span. The internal measured value "0" is shifted by this value. | <i>coF</i> |
| <p>As an alternative: automatic adjustment of the offset in the range 0 bar ± 5 % of the measuring span.</p> <ul style="list-style-type: none">▶ Make sure that the differential pressure is 0 bar or as close as possible to the 0 bar mark.▶ Press [Mode/Enter] until [tcoF] appears.▶ Press [Set] and keep it pressed. <p>> The current offset value (in %) briefly flashes.</p> <ul style="list-style-type: none">▶ Release [SET].▶ Press [Mode/Enter] briefly (= to confirm the new offset value). <p>Reset of the teached value:</p> <ul style="list-style-type: none">▶ Select [coF] and set the value [0]. | <i>tcoF</i> |

9.4 Service functions

9.4.1 Reading of the min/max values for system pressure

| | |
|---|------------------|
| <ul style="list-style-type: none">▶ Select [Hi] or [Lo], briefly press [Set]. [Hi] = maximum value, [Lo] = minimum value. <p>Delete memory:</p> <ul style="list-style-type: none">▶ Select [Hi] or [Lo].▶ Press [Set] and keep it pressed until [----] is displayed.▶ Press [Mode/Enter] briefly. | <i>Hi Lo</i> |
|---|------------------|

9.4.2 Reset of all parameters to factory setting

| | |
|---|------------|
| <ul style="list-style-type: none">▶ Select [rES].▶ Press [Set] and keep it pressed until [----] is displayed.▶ Press [Mode/Enter] briefly. <p>We recommend taking down your own settings in the table before carrying out a reset (→ 13 Factory setting).</p> | <i>rES</i> |
|---|------------|

10 Operation

After power on, the unit is in the Run mode (= normal operating mode). It carries out its measurement and evaluation functions and provides output signals according to the set parameters.

Operating indications → chapter 7 Operating and display elements.

10.1 Reading of the set parameters

- ▶ Press [Mode/Enter] until the requested parameter is displayed.
- ▶ Press [Set] briefly.
- > The unit displays the corresponding parameter value for about 15 s. After another 15 s the unit returns to the Run mode.

UK

10.2 Fault indication

| | |
|-------|--|
| [OL] | Overload pressure (measuring range exceeded) |
| [UL] | Underload pressure (below measuring range) |
| [SC1] | Short circuit in OUT1* |
| [SC2] | Short circuit in OUT2* |
| [SC] | Short circuit in both outputs* |
| [Err] | Flashing: internal fault |

*The output concerned is switched off as long as the short circuit exists.

The messages SC1, SC2, SC, and Err are shown even if the display is switched off.

10.3 Setting ranges

| | | SPx / FHx | | rPx / FLx | | ΔP |
|--------|------|-----------|-------|-----------|------|------|
| | | min | max | min | max | |
| PQ0809 | bar | -0.98 | 1.00 | -0.99 | 0.99 | 0.01 |
| | kPa | -98 | 100 | -99 | 99 | 1 |
| | PSI | -14.2 | 14.6 | -14.4 | 14.4 | 0.2 |
| | inHG | -28.8 | 29.7 | -29.1 | 29.4 | 0.3 |
| PQ0834 | bar | -0.90 | 10.00 | -0.95 | 9.95 | 0.05 |
| | kPa | -90 | 1000 | -95 | 995 | 5 |
| | PSI | -13 | 145 | -14 | 144 | 1 |
| | inHG | -26 | 296 | -28 | 294 | 2 |

ΔP = step increment

11 Werkseinstellung

| | Factory setting | User setting |
|---------|-----------------|--------------|
| SP1/FH1 | 25% VMR* | |
| rP1/FL1 | 23% VMR* | |
| ou1 | Hno | |
| ou2 | Hno | |
| SP2/FH2 | 75% VMR* | |
| rP2/FL2 | 73% VMR* | |
| coF | 0.0 | |
| dS1 | 0 | |
| dr1 | 0 | |
| dS2 | 0 | |
| dr2 | 0 | |
| dAP | 2.5 | |
| diS | d2 | |
| uni | bAr | |
| cLor | r-on | |

* = the indicated percentage of the final value of the measuring range (VMR) of the corresponding sensor in bar is set

More information at www.ifm.com