

CE

Operating instructions  
Contrast sensor

UK

**O5K500**

11470792 / 00 11 / 2016

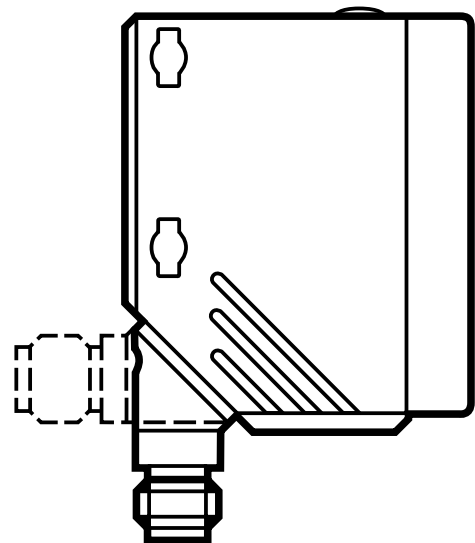

# Contents

1 Preliminary note.....	3
1.1 Symbols used.....	3
2 Functions and features.....	3
3 Installation.....	4
3.1 Installation conditions.....	4
4 Operating and display elements.....	5
5 Electrical connection.....	5
6 Settings.....	6
6.1 The sensor is to switch when the print mark is detected.....	6
6.2 The sensor is not to switch when the print mark is detected.....	6
6.2.1 Setting unsuccessful.....	7
6.3 Setting of maximum sensitivity.....	7
6.4 Electronic lock.....	7
7 Set-up / operation.....	8
8 Maintenance, repair and disposal.....	8
9 Scale drawing.....	9

# 1 Preliminary note

## 1.1 Symbols used

- ▶ Instruction
- > Reaction, result
- [...] Designation of pushbuttons, buttons or indications
- Cross-reference



Important note:

Non-compliance can result in malfunctions or interference.



Information

Supplementary note.

UK

## 2 Functions and features

The contrast sensor detects print marks on objects and materials without contact and indicates them by a switching signal. It evaluates differences in luminosity (= grey scale values and colours).

For the range see the type label.

### 3 Installation

- ▶ Secure the unit to a bracket.
- ▶ Align the sensor to the object to be detected by means of the light spot.

#### 3.1 Installation conditions

- ▶ For the specified operating distance (D) refer to the imprint on the unit or the technical data sheet.

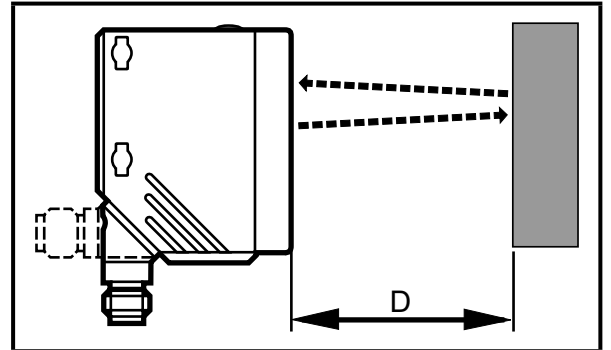

The objects to be detected are to move transversely to the lens of the sensor.

- ▶ If movement is in a different direction, safe switching must be verified.

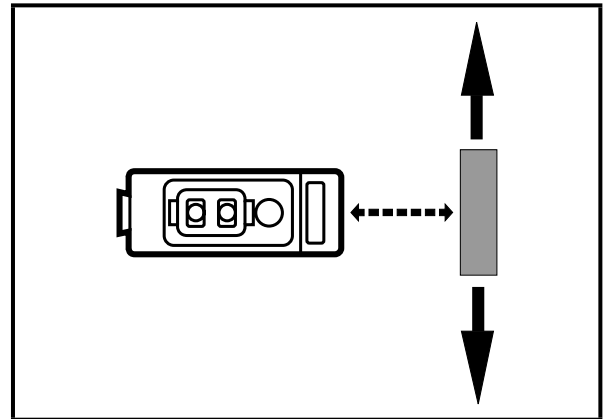

- ▶ Align the sensor so that the light spot hits the mark vertically.

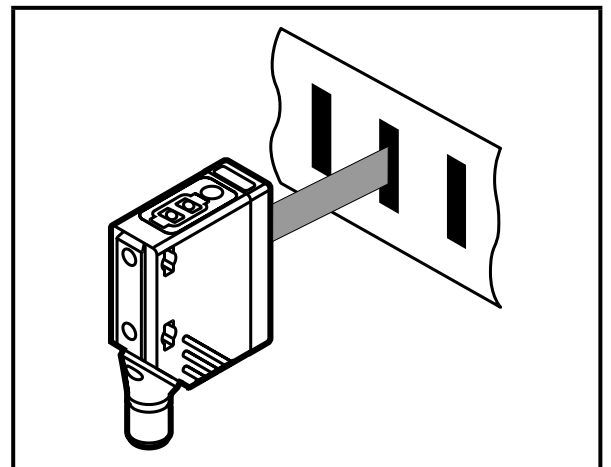

- ▶ To detect highly reflective materials incline the sensor by approx. 15° horizontally to the optical axis.

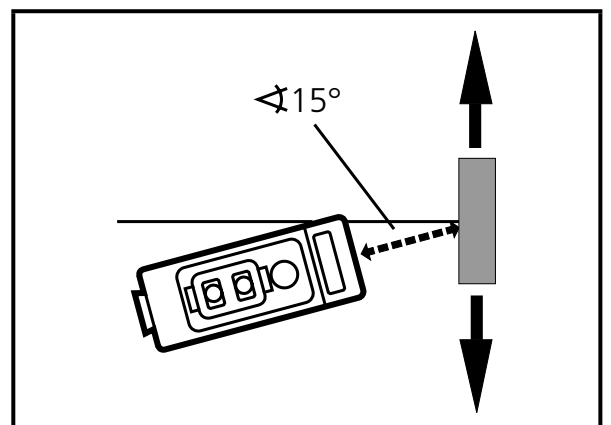

## 4 Operating and display elements

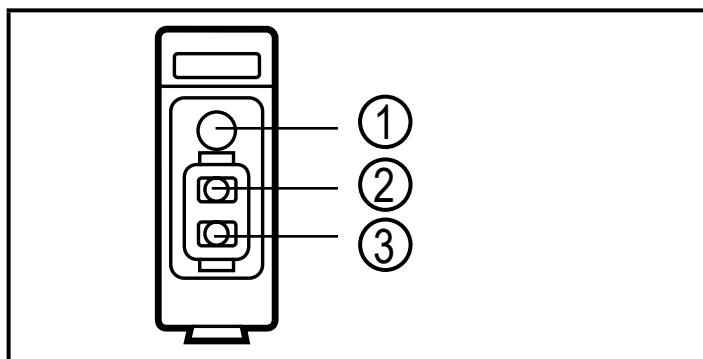

- 1: LED yellow
- 2: OUT on button
- 3: OUT off button

## 5 Electrical connection



The unit must be connected by a qualified electrician.

- ▶ The national and international regulations for the installation of electrical equipment must be adhered to.
  - ▶ Ensure voltage supply to EN 50178.
- ▶ Disconnect power.
- ▶ Connect the unit as follows:

### DC PNP

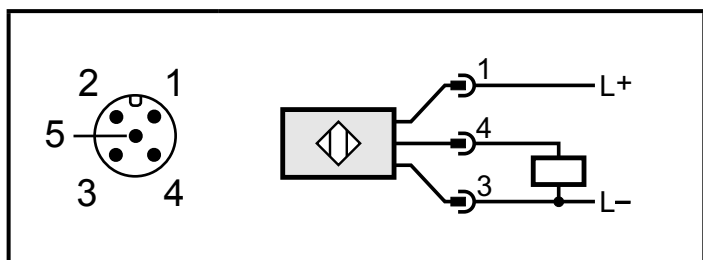

- pin 1 = L+
- pin 3 = L-
- pin 4 = load
- (pin 2 = not connected)
- (pin 5 = not connected)

### DC NPN

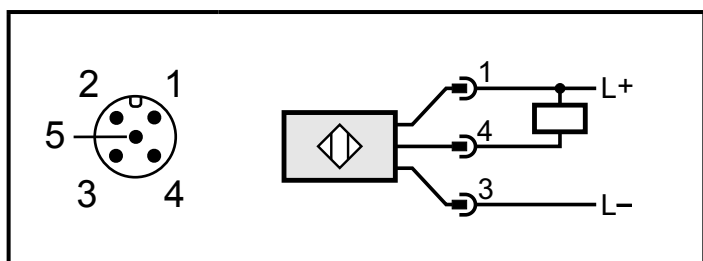

- pin 1 = L+
- pin 3 = L-
- pin 4 = load
- (pin 2 = not connected)
- (pin 5 = not connected)

## 6 Settings

During setting in the application, the sensor automatically selects the colour from the 3 transmitter colours (RGB) with which there is the greatest contrast.

### 6.1 The sensor is to switch when the print mark is detected

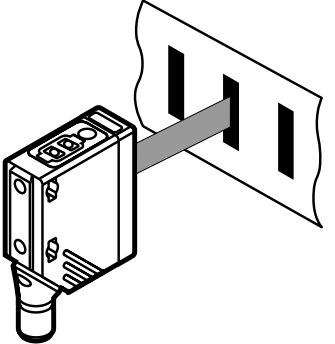
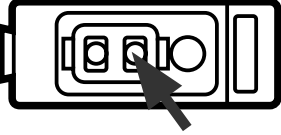
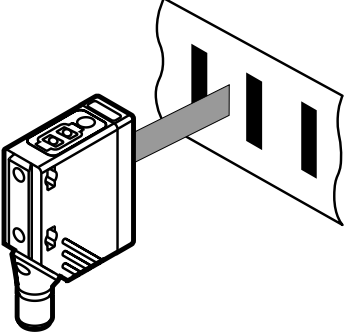
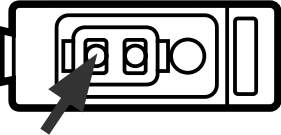
1	▶ Position the light spot on the contrast surface.	
2	▶ Press [OUT on] for 2 s. > LED flashes. ▶ Release [OUT on]. > LED goes out. Measurement of the signal of the print mark with the transmitter colours (RGB). > After 1 s the LED flashes 2 x.	
3	▶ Position the light spot on the background.	
4	▶ Press [OUT off] and release it. > LED goes out. Measurement of the background signal with the transmitter colours (RGB). After 1 s the setting is completed.	

### 6.2 The sensor is not to switch when the print mark is detected

- ▶ Position the light spot on the mark (see figure 1) and press [OUT off] for 2 s.
  - ▶ Position the light spot on the background (see figure 3) and press [OUT on].
- Both settings can also be carried out first with the background (step 3) and then with the mark (step 1).

## 6.2.1 Setting unsuccessful

- > The yellow LED flashes quickly, 8 Hz.
- > The sensor returns to the normal operating mode with unchanged values.

### Possible causes

- Insufficient difference in measurements.
- Max. programming time of 15 min. exceeded.

## 6.3 Setting of maximum sensitivity

- ▶ Align the sensor so that no light is reflected.

### The sensor is to switch when the contrast mark is detected

- ▶ First press [OUT on] and then [OUT off].

### The sensor is to switch when the contrast mark is not detected

- ▶ First press [OUT off], then [OUT on].

After setting the maximum sensitivity, the transmitter colour corresponds to the factory setting (red).



This procedure applies if the signal from the mark is greater than the background signal. If the signal from the mark is lower than the background signal, the buttons need to be pressed in reverse order.

## 6.4 Electronic lock

The unit can be locked electronically to prevent unintentional settings. On delivery the unit is not locked.

- ▶ Press [OUT on] and [OUT off] simultaneously for 10 s.
- > Acknowledgement is indicated by a change of the LED status.
- ▶ To unlock repeat this step.

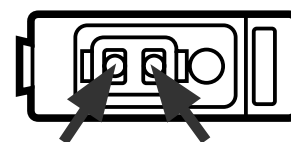

## 7 Set-up / operation

- ▶ Check whether the unit operates correctly.
- > Display by LEDs.

Display	Cause
LED lit	Switching output OUT switched.
LED flashes at 2 Hz	Internal fault.
LED flashes at 8 Hz	Programming unsuccessful.

## 8 Maintenance, repair and disposal

- ▶ Keep the lens of the sensor free from soiling.
- ▶ For cleaning do not use any solvents or cleaning agents which could damage the plastic parts.
- ▶ After use dispose of the unit in an environmentally friendly way in accordance with the applicable national regulations.

Faulty sensors must only be repaired by the manufacturer.



## 9 Scale drawing

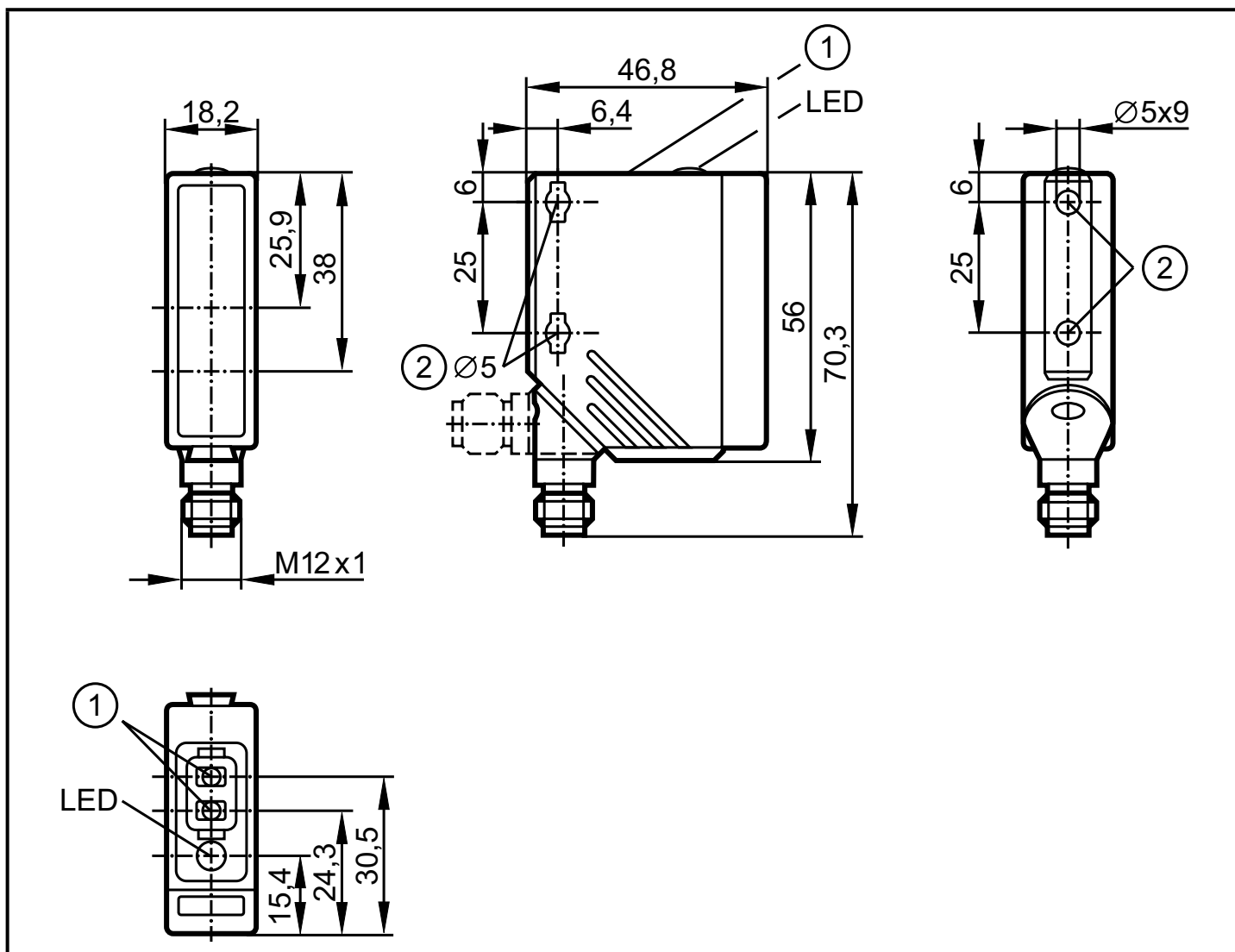

Dimensions in mm

1: Programming buttons

2: When an M5 mounting screw is used the max. tightening torque is 2 Nm.

Technical data and further information at  
[www.ifm.com](http://www.ifm.com) → Select your country → Data sheet direct: