

Original operating instructions  
Fail-safe inductive sensor  
**GG714S**

**UK**

11491852 / 00 11 / 2022

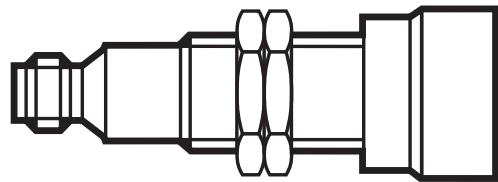

# Contents

1	Preliminary note.....	3
1.1	Symbols used .....	3
1.2	Warning signs used .....	3
2	Safety instructions .....	4
2.1	Safety-related requirements regarding the application.....	4
3	Items supplied.....	5
4	Functions and features .....	5
5	Function .....	6
5.1	Enable zone.....	6
6	Installation.....	7
6.1	Protection against simple defeating.....	7
7	Electrical connection.....	8
8	Operation .....	8
8.1	Switching state of the outputs.....	8
8.1.1	The safe state .....	8
8.1.2	The switched state.....	8
8.1.3	Output characteristics.....	8
8.1.4	Cross fault / short circuit .....	9
8.2	Response times .....	9
9	Technical data.....	10
10	Troubleshooting .....	12
11	Maintenance, repair and disposal .....	12
12	Terms and abbreviations.....	13

# 1 Preliminary note

The instructions are part of the unit. They are intended for authorised persons according to the EMC, Low Voltage and Machinery Directives and safety regulations.

The instructions contain information about the correct handling of the product. Read the instructions before use to familiarise yourself with operating conditions, installation and operation.

Follow the safety instructions.

## 1.1 Symbols used

► Instructions

→ Cross-reference



Important note

Non-compliance can result in malfunction or interference.



Information

Supplementary note.

## 1.2 Warning signs used

### **WARNING**

Warning of serious personal injury.

Death or serious irreversible injuries may result.

## 2 Safety instructions

- Follow the operating instructions.
- Improper use may result in malfunctions of the unit. This can lead to personal injury and/or damage to property during operation of the machine. For this reason note all remarks on installation and handling given in this document. Also adhere to the safety instructions for the operation of the whole installation.
- In case of non-observance of notes or standards, especially when tampering with and/or modifying the unit, any liability and warranty is excluded.
- If the sensor is damaged, the safety function cannot be guaranteed.
- Errors caused by damage cannot be detected by the sensor.
- The unit must be installed, connected and put into operation by a qualified electrician trained in safety technology.
- The applicable technical standards for the corresponding application must be complied with.
- For installation the requirements according to EN 60204 must be observed.
- In case of malfunction of the unit please contact the manufacturer. Tampering with the unit is not allowed.
- Disconnect the unit externally before handling it. Also disconnect any independently supplied relay load circuits.
- After installation, maintenance or repair of the system perform a complete function check.
- Use the unit only in specified environmental conditions (→ 9 Technical data). In case of special operating conditions please contact the manufacturer.
- Use only as described below (→ 4).

### 2.1 Safety-related requirements regarding the application

It must be ensured that the safety requirements of the respective application correspond to the requirements stated in these instructions.

## **! WARNING**

### Failure of the safety function

When used outside of the defined environmental conditions, the safety-related function of the sensor cannot be guaranteed.

- ▶ Use only in accordance with the defined environmental conditions (→ 9 Technical data).

Use of the sensor in the vicinity of ionising radiation is not permitted.

Observe the following requirements:

- ▶ Take measures to avoid metallic objects being placed on the sensing face unintentionally.
- ▶ Adhere to EN 14119 for interlocking devices associated with guards.
- ▶ Adhere to the principle of normally closed operation for all external safety circuits connected to the system.
- ▶ In case of faults within the fail-safe sensor which result in the defined safe state: take measures to maintain the safe state when the complete control system continues to be operated.
- ▶ Replace damaged units.

## **3 Items supplied**

1 fail-safe sensor GG714S with 2 M18 fixing nuts,  
1 original operating instructions GG714S, ident no. 11491852.

If one of the above-mentioned components is missing or damaged, please contact one of the ifm branch offices.

## **4 Functions and features**

The fail-safe inductive sensor GG714S detects metal without contact.

Safety function SF: the safe state (output stage switched off; logic "0") is achieved when undamping greater than or equal to the safe switch-off distance  $s_{ar}$  (→ 9 Technical data).

Also observe the notes on installation of the sensor (→ 6 Installation).

The fail-safe inductive sensor is a proximity device with defined behaviour under fault conditions (PDDb) to IEC 60947-5-3.

The fail-safe sensor conforms to Performance Level d according to EN ISO 13849-1 as well as to the requirements SIL 2 to IEC 61508 and meets SILcl 2 to IEC 62061.

The unit corresponds to the classification I2A18SP2 to IEC 60947-5-2 for non-flush installation (→ 6 Installation).

The fail-safe inductive sensor has been certified by TÜVNord.

## 5 Function

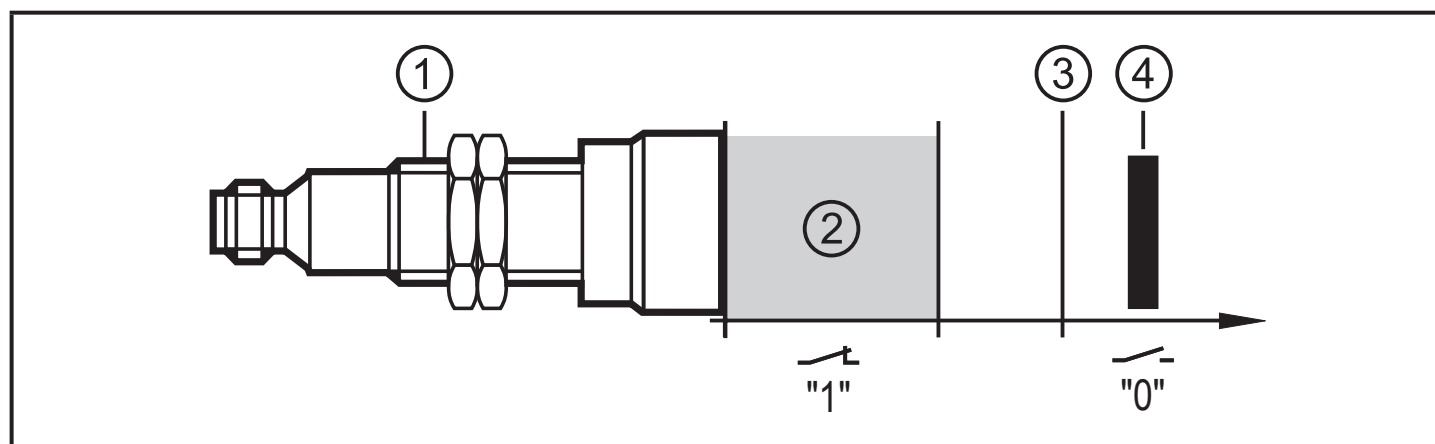

- 1: fail-safe sensor
- 2: enable zone
- 3: safe switch-off distance  $s_{ar}$
- 4: target

### 5.1 Enable zone

The outputs (OSSD) are only enabled when a damping target is present in the enable zone. Outside this enable zone the outputs remain switched off.

The safe switch-off distance  $s_{ar}$  is  $> 11$  mm.

 The enable zone is different if damping elements which deviate from the standard target plate in terms of material, form and size are used.

Enable zone for selected materials\*:

Material	Enable zone
FE360 (= mild steel)	0...6,5 mm
Stainless steel	0...4,1 mm
AlMg3G22	0...1,7 mm
CuZn37	0...1,7 mm
Copper	0...0,9 mm

\* Typical values for damping with a reference target of 24 x 24 x 1 mm and non-flush installation to IEC 60947-5-2 at an ambient temperature of 20 °C.

## 6 Installation

The unit is **non-flush** mountable according to IEC 60947-5-2, type I2A18SP2.

- ▶ Ensure the unit cannot work loose (tightening torque  $\leq 25$  Nm).
- ▶ Adhere to the installation conditions in accordance with the figures 1 to 3:

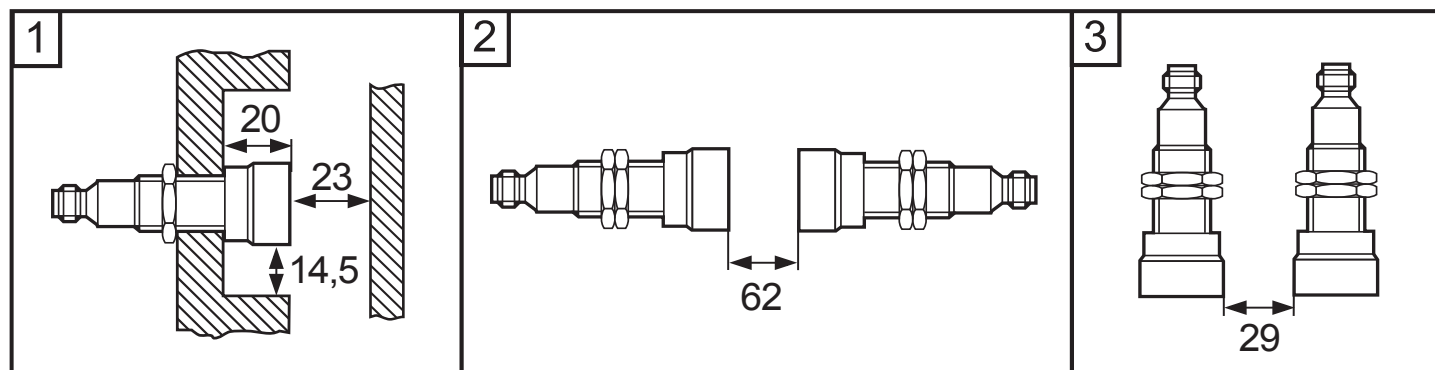

- ▶ Tighten the socket according to the manufacturer's indications. Observe the tightening torque for the ifm socket (e.g. EVxxxx: 0.6...1.5 Nm).

 Flush installation of the fail-safe sensor is not permitted since this can result in an increase of the sensing range up to enabling of the outputs (OSSDs).

### 6.1 Protection against simple defeating

The fail-safe sensor reacts to metal objects, e.g. the frame of a safety door. Other metal objects that are not intended to enable the sensor must not be allowed to enable the fail-safe sensor unintentionally.

-  ▶ Take measures to prevent metal objects, except the designated target, from being placed on the sensing face or in the enable zone unintentionally.

## 7 Electrical connection

- ▶ Disconnect power. Also disconnect any independently supplied relay load circuits.
- ▶ Supply voltage: connect L+ to pin 1 and L- to pin 3 of the connector.

 The nominal voltage is 24 V DC. This voltage may vary between 19.2 V and 30 V incl. 5 % residual ripple to EN 61131-2.

 In case of a single fault the supply voltage must not exceed a maximum of 40 V DC. (This requires the safe separation between power supply and transformer.)

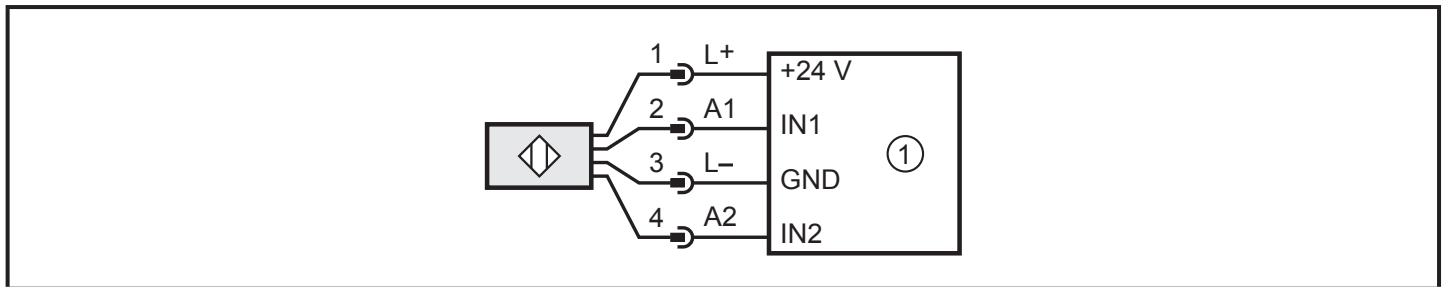

1: safety-related logic unit \*

## 8 Operation

### 8.1 Switching state of the outputs

#### 8.1.1 The safe state

The safe state is when at least one of the outputs A1 or A2 (OSSDs) is switched off (zero-current state: logic "0").

If one of the outputs A1 or A2 is switched off, the subsequent safety-related logic unit must bring the complete system into the state defined as safe.

#### 8.1.2 The switched state

If the damping element is in the enable zone and if there is no sensor error, both outputs A1 and A2 (OSSDs) are enabled (logic "1").

#### 8.1.3 Output characteristics

The output characteristics are compatible with the input characteristics to EN 61131-2 type 1 or 2:

Logic "1"	$\geq 15 \text{ V}$	2...15 mA
	$\geq 11 \text{ V}$	15...30 mA
Logic "0"	$\leq 5 \text{ V}$	leakage current 0.2 mA



The interface corresponds to interface type C class 1 according to the ZVEI position paper "Klassifizierung binärer 24-V-Schnittstellen mit Testung im Bereich der Funktionalen Sicherheit" (Classification of binary 24V interfaces tested with regard to functional safety).

### 8.1.4 Cross fault / short circuit

- A cross fault between both outputs (A1 and A2) is detected by the fail-safe sensor and results in the outputs (OSSD) being switched off at the next safety request. The outputs A1 and A2 remain switched off until the error has been removed or a voltage reset has been carried out.
- A cross fault (short circuit) between output A2 and the supply voltage results in the other output A1 being switched off in case of a safety request.
- When there is no current flow on the output stage, back feeding > 3.5 V will lead to malfunction.
- The device carries out self-tests for the switch-off capability on A2.

UK

## 8.2 Response times

Response time on safety request (removal from the enable zone)	$\leq 1 \text{ ms}$						
Response time when approaching the enable zone (enable time)	$\leq 1 \text{ ms}$						
Risk time / response time for safety-related faults	$\leq 20 \text{ ms}$						
Simultaneity of switching on and off of the outputs in case of a safety request	$\leq 1 \text{ ms}$						
Test pulse duration $t_{i\_max}$ on A2 (1)	$\leq 1 \text{ ms}$						
Test pulse interval T on A2 (2)	<table style="border: none;"> <tr> <td><math>T_{typ}</math></td> <td>180 ms</td> </tr> <tr> <td><math>T_{max}</math></td> <td>300 ms</td> </tr> <tr> <td><math>T_{min}</math></td> <td>100 ms</td> </tr> </table>	$T_{typ}$	180 ms	$T_{max}$	300 ms	$T_{min}$	100 ms
$T_{typ}$	180 ms						
$T_{max}$	300 ms						
$T_{min}$	100 ms						

1: Test pulse duration  
2: Test pulse interval T

## 9 Technical data

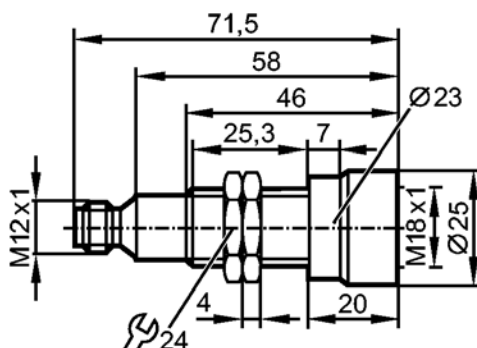

### Product characteristics

Fail-safe inductive sensor

Metal thread M18 x 1

M12 connector

Enable zone 0...6.5 mm; [nf] non-flush mountable

Complies with the requirements:

EN ISO 13849-1: 2015 category 2 PL d

IEC 61508: SIL 2

IEC 62061: SILcl 2

### Application

Type of operation

continuous operation (maintenance-free)

### Electrical data

Electrical design

DC PNP

Operating voltage [V]

24 DC (19.2...30 DC)

Rated insulation voltage [V]

30

Current consumption [mA]

< 30

Protection class

III

Reverse polarity protection

yes

### Outputs

Output function

2 x OSSD (A1 and A2)

Output data

Interface type C class 1

Output voltage at 24 V

compatible with EN 61131-2 inputs type 1, 2

Voltage drop [V]

< 2.5; (30 mA)

Current rating [mA]

100

Short-circuit protection

yes

Max. capacitive load CL\_max [nF]

20

### Range

Enable zone [mm]

0...6.5

Safe switching off distance s(ar) [mm]

11

### Reaction times

Power-on delay time [s]

1

Response time to safety request [ms]	≤ 1
Response time when approaching the enable zone (enable time) [ms]	≤ 1
Risk time (response time for safety -related faults) [ms]	≤ 20

### Environment

Ambient temperature [°C]	-40...70
Rate of temperature change [K/min]	0.5
Max. relative air humidity [%]	5...95, briefly 5...70, permanently
Air pressure [kPa]	80...106
Height above sea level [m]	≤ 2000
UV radiation	DIN ISO 4892-1, DIN ISO 4892-2
Chemical media	<p>Test according to ISO 16750-5</p> <p>The following media were tested at 75 °C for 22 hours:</p> <ul style="list-style-type: none"> <li>- Liebherr Hydraulik 37</li> <li>- Liebherr Hydraulik Gear ATF</li> <li>- Liebherr Hydraulik Plus Arctic <ul style="list-style-type: none"> <li>- diesel</li> <li>- biodiesel</li> <li>- brake fluid</li> <li>- urea</li> </ul> </li> </ul> <p>The following media were tested at 25 °C for 22 hours:</p> <ul style="list-style-type: none"> <li>- battery acid</li> <li>- cold cleaner</li> <li>- ammonia-based cleaner</li> </ul> <p>The following media were tested at 25 °C for 2 hours:</p> <ul style="list-style-type: none"> <li>- wheel cleaner</li> </ul>
Salt spray	IEC 60068-2-52
Protection	IP 65 / IP 67 / IP 69K; with ifm socket duly screwed on

UK

### Tests / approvals

EMC	IEC 60947-5-2	
	IEC 60947-5-3	
	EN 60947-5-2	
	EN 61000-4-2 ESD:	6 kV CD / 8 kV AD
	EN 61000-4-3 HF radiated:	20 V/m
	EN 61000-4-4 Burst:	2 kV
	EN 61000-4-6 HF conducted:	10 V
	EN 61000-4-8:	30 A/m
	EN 55011:	class B
Shock resistance	IEC 60947-5-2	
Vibration resistance	IEC 60947-5-2	

### Safety classification

Mission time TM [h]	≤ 87600, (10 years)
Safety-related reliability PFHd [1/h]	1.0E-07

### Mechanical data

Mounting	non-flush mountable
Housing materials	housing: stainless steel 316Ti / 1.4571; cover: PBT; connector: Tecatron GF40
Weight [kg]	0.116

### Electrical connection

Connection	M12 connector; Gold-plated contacts
------------	-------------------------------------

### Wiring

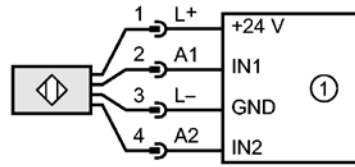

1: Safety-related logic unit

### Accessories

Accessories (included)

2 lock nuts

### Remarks

Remarks

Unless stated otherwise, all data refer to the 24x24x1 mm reference target plate to IEC 60947-5-2 (FE360 = mild steel) over the whole temperature range.

Pack quantity

[piece]

1

ifm electronic gmbh • Friedrichstraße 1 • 45128 Essen — We reserve the right to make technical alterations without prior notice. — GB — GG714S-02 — 19.05.2016

## 10 Troubleshooting

Problem	Possible cause	Troubleshooting
Sensor does not switch, not even after undamping and redamping	Sensor was brought into the safe state (logic "0"). Cause: <ul style="list-style-type: none"> <li>• cross fault between both outputs A1 and A2</li> <li>• cross fault between output A2 and the supply voltage</li> <li>• error in the sensor detected</li> </ul>	<ul style="list-style-type: none"> <li>• Remove the cross fault</li> <li>• Replace the unit</li> </ul>
No close zone	Due to its characteristics (material, form, size), the damping element displaces the enable zone until directly in front of the sensing face	If possible, change the material, form or size of the damping element (→ 5.1 Enable zone)

## 11 Maintenance, repair and disposal

If used correctly, no maintenance and repair measures are necessary.

Only the manufacturer is allowed to repair the unit.

After use dispose of the unit in an environmentally friendly way in accordance with the applicable national regulations.

## 12 Terms and abbreviations

OSSD	Output Signal Switch Device	
PDDDB	Proximity devices with defined behaviour under fault conditions	
PFH (PFH <sub>D</sub> )	Probability of (dangerous) Failure per Hour	
PL	Performance Level	PL to EN ISO 13849-1
SIL	Safety Integrity Level	SIL 1-4 to IEC 61508. The higher the SIL, the lower the probability that a safety function will fail.
SIL <sub>cl</sub>	Safety Integrity Level <sub>claim limit</sub>	According to IEC 62061
T <sub>M</sub>	Mission time	Lifetime to EN 60947-5-3 (= max. service life)

UK