

Operating instructions
Flow monitors

SI0551
SI5004

UK

11458757 / 00 04 / 2021

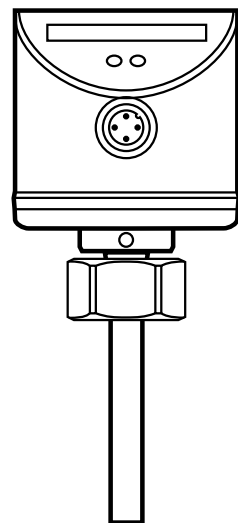

Contents

1 Safety instructions	3
2 Functions and features	4
2.1 Application area	4
2.2 Operating principle flow monitoring	4
3 Installation	5
3.1 Installation location	5
3.2 Sources of interference in the pipe system	6
3.3. Mounting operation.....	6
4 Electrical connection.....	7
5 Operating and display elements	7
6 Set-up and settings for water.....	8
6.1 High flow adjustment (optional)	8
7 Additional settings (optional).....	9
7.1 Low flow adjustment.....	9
7.2 Restore the factory setting (reset)	9
7.3 Lock / unlock the unit.....	9
8 Error during adjustment.....	10
9 Operation.....	10
10 Maintenance	11

Preliminary note

- An instruction is indicated by “▶”:
Example: ▶ Check whether the unit operates correctly.
- A reaction to the action is indicated by ">":
Example: > LED 9 lights.

1 Safety instructions

- Please read the product description prior to set-up of the unit. Ensure that the product is suitable for your application without any restrictions.
- The unit conforms to the relevant regulations and EC directives.
- Improper or non-intended use may lead to malfunctions of the unit or to unwanted effects in your application.
- That is why installation, electrical connection, set-up, operation and maintenance of the unit must only be carried out by qualified personnel authorised by the machine operator.

For the scope of validity cULus:

The device shall be supplied from an isolating transformer having a secondary Listed fuse rated as noted in the following table.

Overcurrent protection		
Control-circuit wire size		Maximum protective device rating Ampere
AWG	(mm ²)	
26	(0.13)	1
24	(0.20)	2
22	(0.32)	3
20	(0.52)	5
18	(0.82)	7
16	(1.3)	10

2 Functions and features

2.1 Application area

The unit monitors the flow of liquid media.

2.2 Operating principle flow monitoring

- The unit detects the flow speed to the calorimetric measuring principle and converts it into an analog output signal (4...20 mA).

The output signal corresponds to the characteristic curve of the sensor. Like the row of LEDs it indicates the relative flow velocity within the detection range set.

In case of excess flow (flow velocity exceeds the detection range) the output signal increases to 20...22 mA.

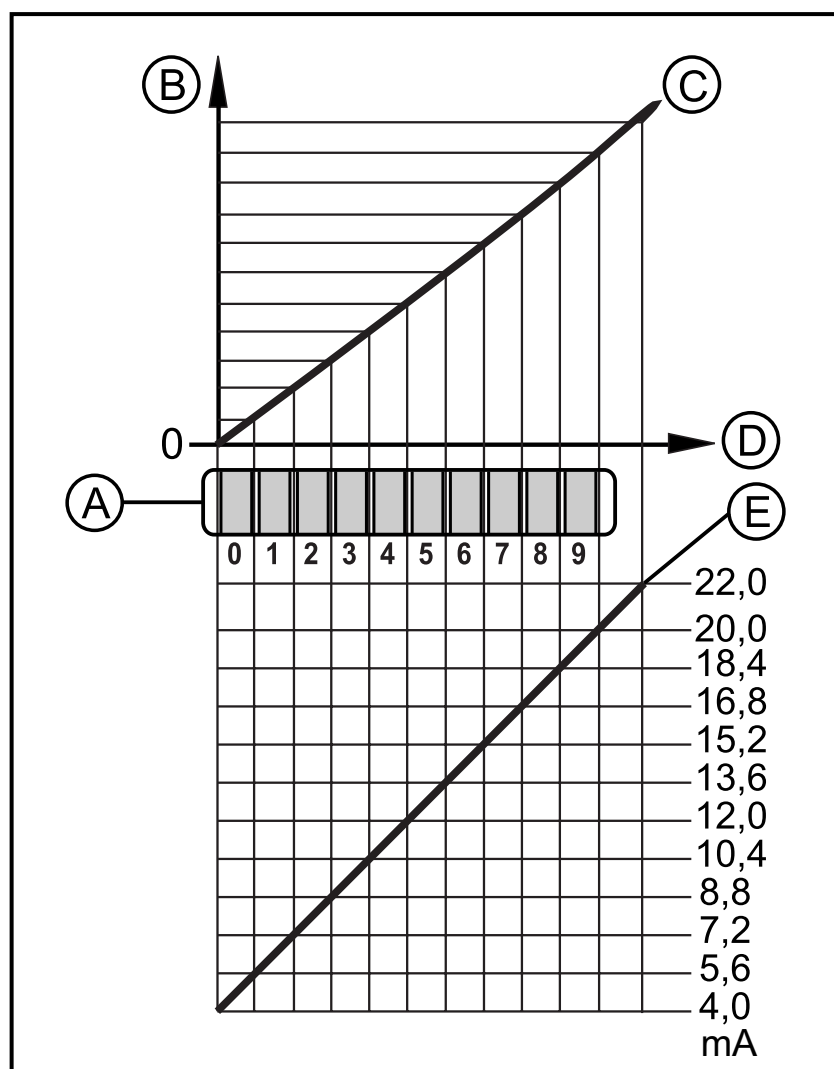

A: operation display (row of LEDs)
B: flow velocity
C: characteristic curve
D: sensor signal
E: output signal in mA

The unit is delivered with the following factory setting: monitoring range = 5...100 cm/s in water.

The typical response time of the unit is 1...10 s.

3 Installation

Using process adapters the unit can be adapted to different process connections.

- Adapters have to be ordered separately as accessories.
A correct fit of the unit and ingress resistance of the connection are only ensured using ifm adapters.
- For small flow rates ifm adapter blocks are available.

3.1 Installation location

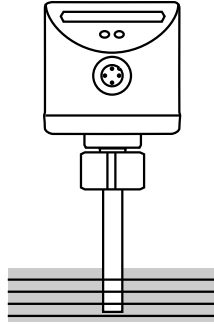
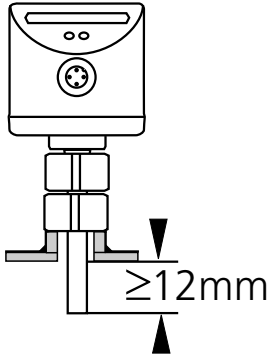
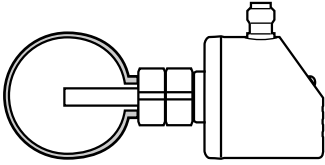
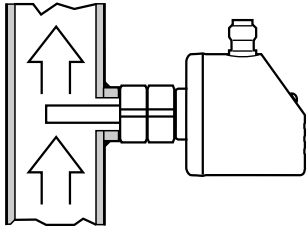
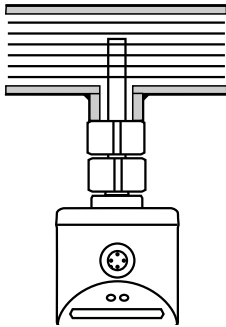
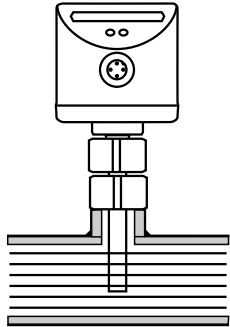
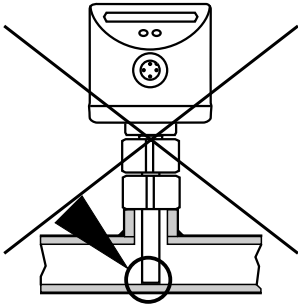
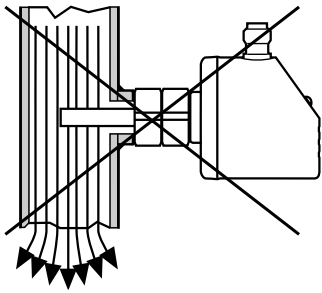
<p>General</p> <ul style="list-style-type: none"> • The sensor tip is to be completely surrounded by the medium. • Insertion depth of the sensor: minimum 12 mm. 		
<p>Recommended</p> <ul style="list-style-type: none"> • For horizontal pipes: mounting from the side. • For vertical pipes: mounting in the rising pipe. 		
<p>Conditional</p> <ul style="list-style-type: none"> • Horizontal pipe /mounting from the bottom: if the pipe is free from build-up. • Horizontal pipe /mounting from the top: if the pipe is completely filled with medium. 		
<p>To avoid</p> <ul style="list-style-type: none"> • The sensor tip must not be in contact with the pipe wall. • Do not mount in downpipes that are open at the bottom! 		

3.2 Sources of interference in the pipe system

Components integrated in the pipes, bends, valves, reductions, etc. lead to turbulence of the medium. This affects the function of the unit.

Recommendation: Adhere to the distances between sensor and sources of interference:

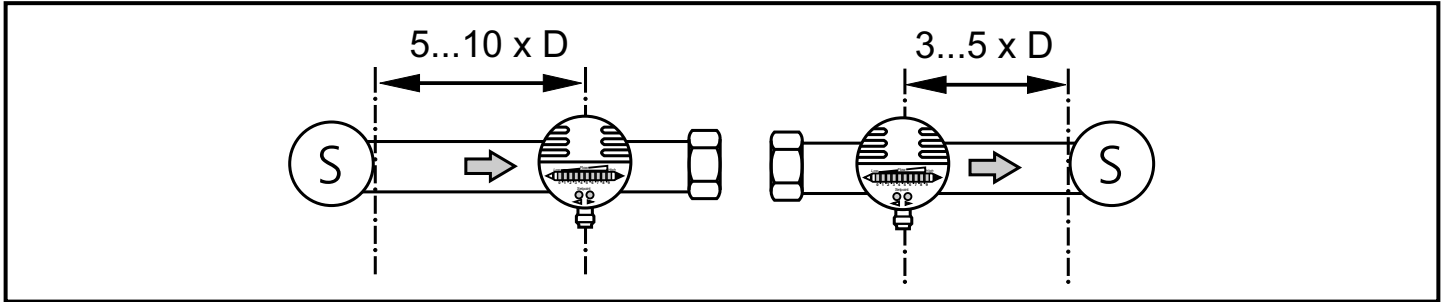

D = pipe diameter; S = sources of interference

3.3. Mounting operation



- ▶ Ensure that the system is free of pressure during installation.
- ▶ Ensure that no media can leak at the mounting location during installation.

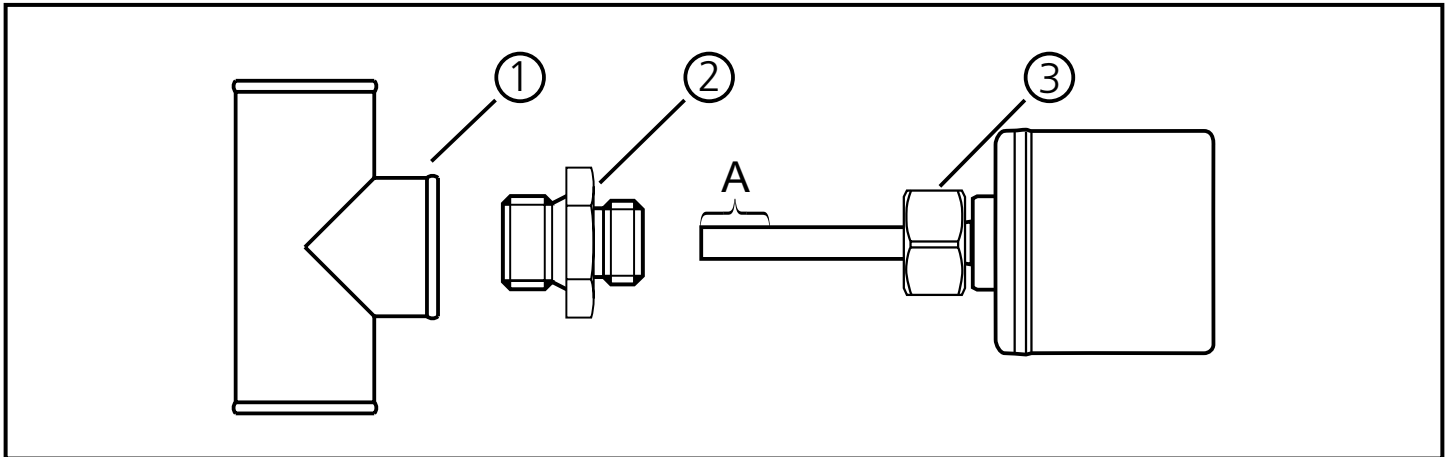

- ▶ Grease the threads of the process connection (1), adapter (2) and nut (3).
Note: The sensor tip (A) must not be in contact with grease.
- ▶ Screw the suitable adapter into the process connection.
- ▶ Place the flow monitor onto the adapter and tighten the nut. Tightening torque 25 Nm. Ensure that the unit is correctly oriented.

4 Electrical connection



The unit must be connected by a qualified electrician.

The national and international regulations for the installation of electrical equipment must be adhered to.

Voltage supply to EN 50178, SELV, PELV.

- ▶ Disconnect power.
- ▶ Connect the unit as follows:

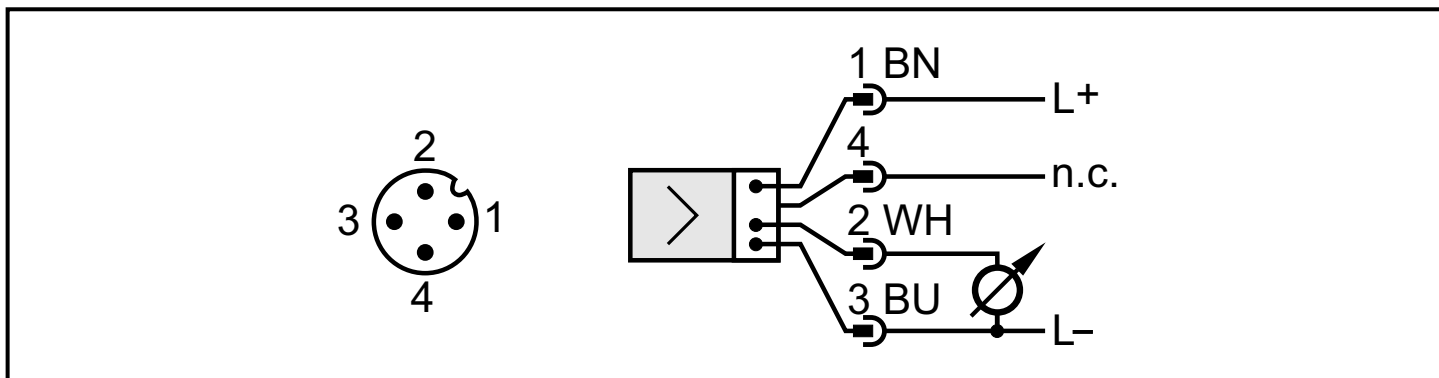

Core colours of ifm sockets:

1 = BN (brown), 2 = WH (white), 3 = BU (blue)

n.c. = not connected

5 Operating and display elements

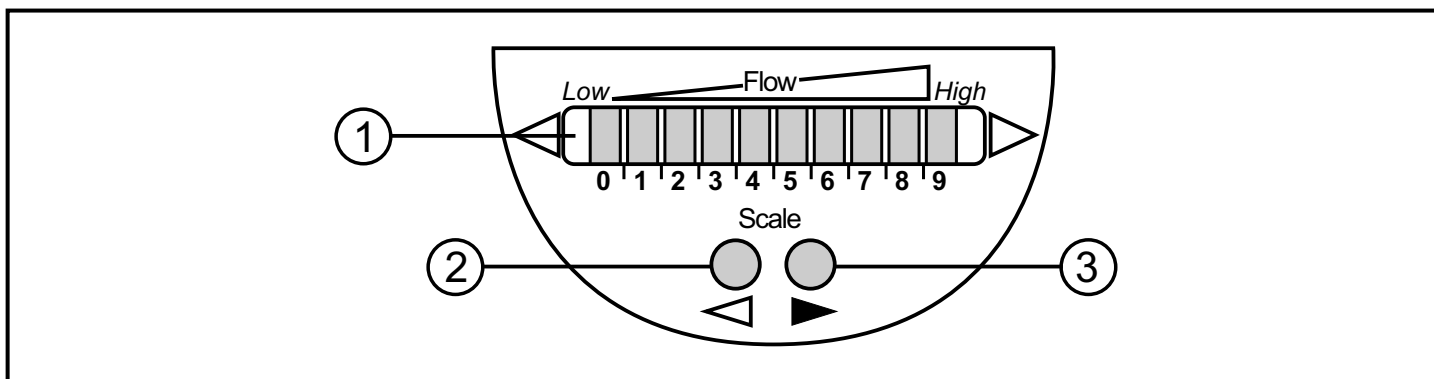

1: Operation display

- The green LEDs indicate the current flow (the LEDs 0 to 9 represent the range between no flow and maximum flow).

2, 3: Setting buttons for adjustment

6 Set-up and settings for water

(For media other than water → 7.1: Low flow adjustment).

- ▶ Switch on the supply voltage.
- > All LEDs light and go out again step by step. The unit is in the operating mode.
- ▶ Let the normal flow circulate in the installation.
- ▶ Check the display and determine further actions.

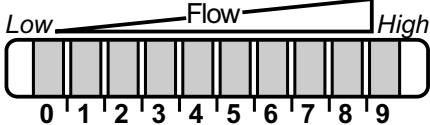
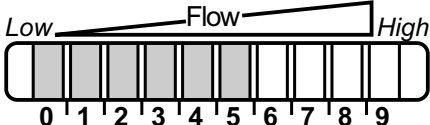
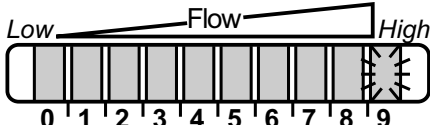
1		The factory setting is suitable for the application. ▶ No further settings are required.
2		Your normal flow is below the representation range of the display. ▶ Carry out high flow adjustment (→ 6.1).
3		Your normal flow exceeds the representation range of the display (LED 9 flashes). ▶ Carry out high flow adjustment (→ 6.1).

You can restore the factory setting any time. (→ 7.2).

6.1 High flow adjustment (optional)

The unit determines the existing flow as normal flow and adapts the display representation (all LEDs light green).

Proceed as follows:

- ▶ Let the normal flow circulate in the installation.
- ▶ Press the pushbutton  and keep it pressed.
- > LED 9 lights, after approx. 5 s it flashes.
- ▶ Release the pushbutton.

The unit is now adapted to your flow conditions. It passes into the operating mode, the display should now show example 1.

7 Additional settings (optional)

7.1 Low flow adjustment

If the unit is used in media other than water, you should additionally adapt the unit to the minimum flow.

Note: The following adjustment must only be carried out after the high flow adjustment.

Proceed as follows:

- ▶ Let the minimum flow circulate in the installation or ensure flow standstill.
- ▶ Press the pushbutton  and keep it pressed.
- > LED 0 lights, after approx. 5 s it flashes.
- ▶ Release the pushbutton. The unit adopts the new value and passes into the operating mode.

UK

7.2 Restore the factory setting (reset)

- ▶ Press the pushbutton  for at least 15 s.
- > LED 9 lights, after approx. 5 s it flashes.
- > After approx. 15 s LEDs 0...9 flash orange.
- ▶ Release the pushbutton. All settings are reset to the factory setting:
 - operating area: 5 ...100 cm/s for water
 - unlocked.

7.3 Lock / unlock the unit

The unit can be locked electronically to prevent unintentional settings.

- ▶ Press both setting pushbuttons simultaneously for at least 10 s in the operating mode.
- > The indication goes out, the unit locks or unlocks.

On delivery: unlocked.

8 Error during adjustment

If no adjustment is possible, all LEDs flash red. The unit then passes into the operating mode with unchanged values.



Possible cause /aid:

Error during installation.	► Read chapter 3 Installation. Check whether all requirements have been met.
The difference between maximum flow and minimum flow is too small.	► Increase the flow difference and carry out the adjustment once again.
The sequence high flow /low flow adjustment was not adhered to.	► Carry out the two adjustment operations again in the right sequence.

9 Operation

After every power on all LEDs light and go out again step by step (during this time the output signal is 20 mA). The unit is then ready for operation.

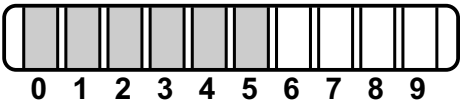
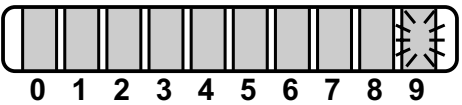
In case of power failure or interruption all settings remain.

Operating indicators	
 <p>0 1 2 3 4 5 6 7 8 9</p>	Green LED bar: current flow within the representation range.
 <p>0 1 2 3 4 5 6 7 8 9</p>	LED 9 flashes: current flow above the representation range.
 <p>0 1 2 3 4 5 6 7 8 9</p>	LED 0 flashes: current flow far below the representation range.
Interference indicators	
Display OFF (no LED lights):	Operating voltage too low (< 19 V) or failed. Ensure a correct voltage supply.

10 Maintenance

Recommended maintenance:

- ▶ Check the sensor tip for build-up from time to time.
- ▶ Clean it using a soft cloth. Stubborn build-up (e.g. lime) can be removed using a common vinegar cleaning agent.

UK

More information at www.ifm.com

