

Operating Instructions
Pressure sensor
PP052x

UK

11450556 / 01 04 / 2023

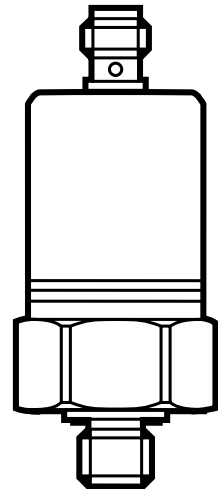

Contents

1 Preliminary note.....	3
1.1 Symbols used	3
2 Safety instructions	3
3 Functions and features	4
3.1 Application area	4
4 Function.....	4
4.1 Communication, parameter setting and evaluation	4
4.2 Operating modes	5
4.3 Pressure monitoring / switching functions	6
4.4 Teach function.....	7
5 Installation.....	8
6 Electrical connection.....	8
7 Parameter setting	9
7.1 Adjustable parameters.....	9
7.2 Menu structure / display in PP2001	10
7.3 General parameter setting.....	11
7.4 Setting for operating mode 1 (2 switching outputs)	11
7.5 Setting for operating mode 2 (switching output + teach input)	12
7.6 Setting for operating mode 3 (switching output + diagnostic output).....	12
7.7 Setting for communication mode	13
7.8 User settings (optional)	13
7.9 Service functions	14
7.10 Teach set point SP2.....	14
8 Operation	16
8.1 Operation indication by LEDs	16
8.2 Fault indication	16
9 Technical data.....	17
9.1 Setting ranges for the set points.....	18
10 Factory setting	19

1 Preliminary note

1.1 Symbols used

► Instructions

> Reaction, result

[...] Designation of keys, buttons or indications

→ Cross-reference



Important note

Non-compliance may result in malfunction or interference.



Information

Supplementary note.

UK

2 Safety instructions

- The device described is a subcomponent for integration into a system.
 - The manufacturer of the system is responsible for the safety of the system.
 - The system manufacturer undertakes to perform a risk assessment and to create a documentation in accordance with legal and normative requirements to be provided to the operator and user of the system. This documentation must contain all necessary information and safety instructions for the operator, the user and, if applicable, for any service personnel authorised by the manufacturer of the system.
- Read this document before setting up the product and keep it during the entire service life.
- The product must be suitable for the corresponding applications and environmental conditions without any restrictions.
- Only use the product for its intended purpose (→ Functions and features).
- Only use the product for permissible media (→ Technical data).
- If the operating instructions or the technical data are not adhered to, personal injury and/or damage to property may occur.
- The manufacturer assumes no liability or warranty for any consequences caused by tampering with the product or incorrect use by the operator.
- Installation, electrical connection, set-up, operation and maintenance of the unit must be carried out by qualified personnel authorised by the machine operator.
- Protect units and cables against damage.

- Use in gases at pressures > 25 bar only after contacting the manufacturer ifm.
- High-pressure units (400 bar) are supplied with a pressure relief mechanism and an integrated damping device to comply with the regulations for UL approval and to avoid any risk of injury in case of bursting when bursting pressure is exceeded.



Any manipulation of the damping device is not permissible.

When the damping device is removed, there is no damping function any more.

ATTENTION: risk of injury!

For units with cULus approval this approval becomes invalid when the damping device is removed.

3 Functions and features

The unit monitors the system pressure in a plant.

3.1 Application area

- The unit is suited for use in mobile vehicles.
- Type of pressure: relative pressure



Avoid static and dynamic overpressure exceeding the given overload pressure by taking appropriate measures.

The indicated bursting pressure must not be exceeded.

Even if the bursting pressure is exceeded only for a short time, the unit may be destroyed. NOTE: Risk of injury!

Use in gases at pressures > 25 bar only after contacting the manufacturer ifm.

4 Function

4.1 Communication, parameter setting and evaluation

- The unit generates output signals according to the parameter settings.
- The unit is laid out for bidirectional communication. So, the following options are possible:
 - Remote display: reading and display of the current system pressure.
 - Remote evaluation: transfer of switching signals (only with PP2001).
 - Remote parameter setting: reading and changing current parameter settings with PP2001 or FDT service program ifm Container.

- Using PP2001 and the FDT service program ifm Container, the current parameter settings can be stored and transferred to other units of the same type.



The program library of the available DTM objects can be found at www.ifm.com.

4.2 Operating modes

1	Pressure sensor with 2 switching outputs	
	2 limit values for pressure can be monitored. Pin 4 = output 1, pin 2 = output 2.	Parameter setting → 7.4
2	Pressure sensor with one switching output and one teach input	
	One limit value for pressure can be monitored. The current system pressure can be set as limit value at any time by a teach signal. Pin 4 = input for teach signal, pin 2 = switching output.	Parameter setting → 7.5 Teach operation → 7.10
3	Pressure sensor with one switching output and one diagnostic output.	
	One limit value for pressure can be monitored. In addition, a fault signal is provided on output 2: in case of a fault, output 2 is inactive. Pin 4 = switching output, pin 2 = output for diagnostic signal.	Parameter setting → 7.6
4	Communication mode	
	There are 2 options for bidirectional communication: <ul style="list-style-type: none"> • Communication with ifm handheld programming unit PP2001. • Communication with PC. For communication with the PC, the FDT service program ifm Container (order no. E30110) is available. For communication mode, no parameter setting is necessary. Using pin 4 (data channel), data can be read in and out at any time. NOTE: voltage supply for communication mode: 18...32 V.	

For the switching functions → 4.3; For the teach function → 4.4.

UK

4.3 Pressure monitoring / switching functions

The unit compares the process value to the set limit values (set points). The NPN transistor output is switched when the limit values are exceeded or not reached.

Each output can be configured separately:

- Hysteresis function / normally open: $[OUx] = [Hno]$ (\rightarrow fig. 1).
- Hysteresis function / normally closed: $[OUx] = [Hnc]$ (\rightarrow fig. 1).
First the set point is set, then the reset point with the requested difference.
- Window function / normally open: $[OUx] = [Fno]$ (\rightarrow fig. 2).
- Window function / normally closed: $[OUx] = [Fnc]$ (\rightarrow fig. 2).
The width of the window can be set by means of the difference between SP and rP. SP = upper value, rP = lower value.

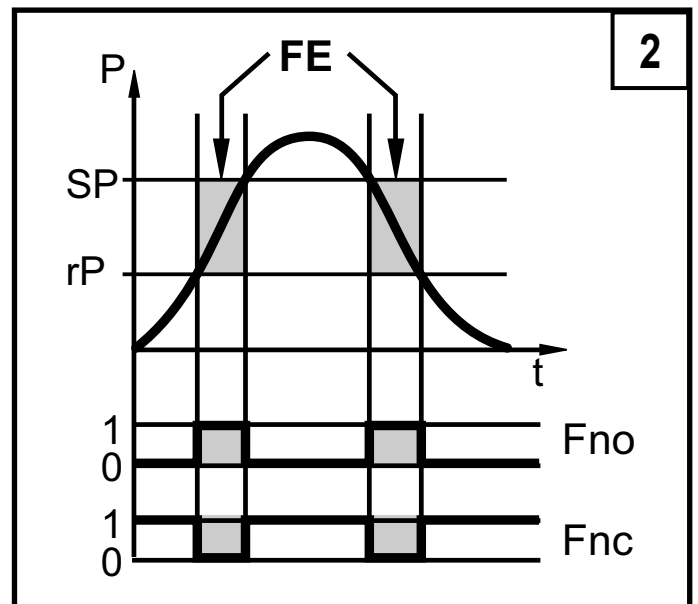
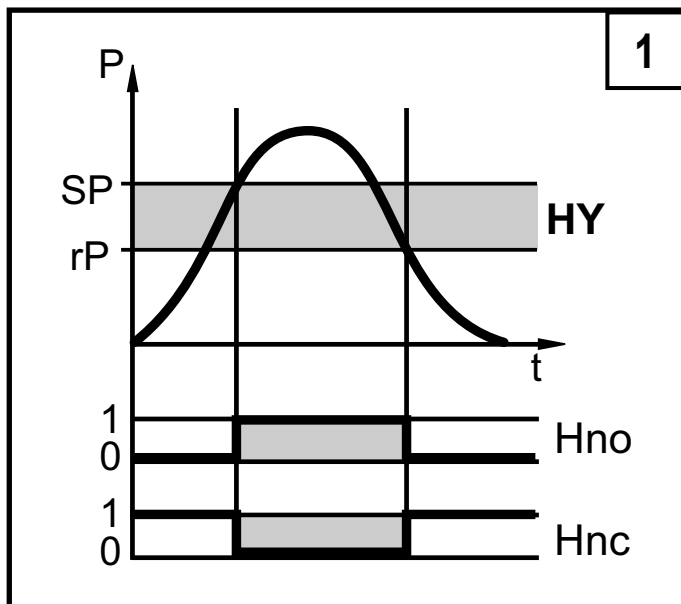

P = system pressure; HY = hysteresis; FE = window

4.4 Teach function

- Teach for hysteresis function:

During the teach operation, the current system pressure is taken as set point. The set hysteresis remains constant: $SP2 = \text{system pressure}$, $rP2 = \text{system pressure} - \text{hysteresis}$. Carry out teach operation \rightarrow 7.10.

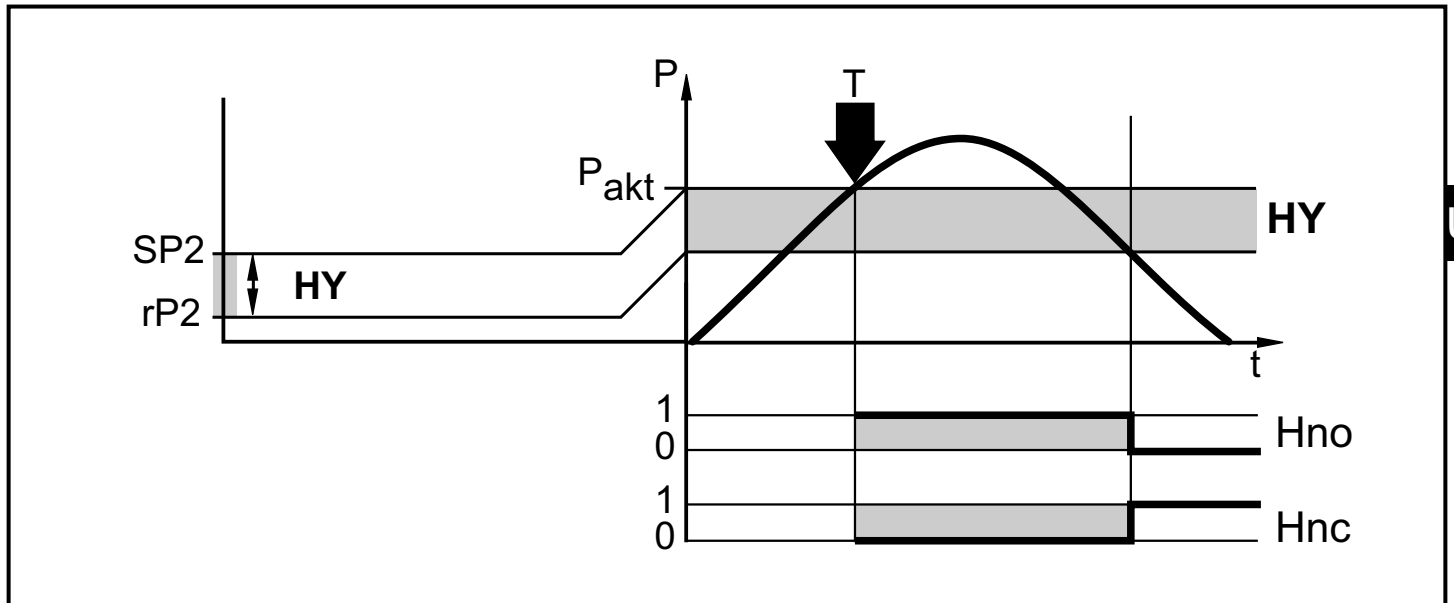

$P = \text{system pressure}$; $P_{akt} = \text{current system pressure}$; $HY = \text{hysteresis}$; $T = \text{time of teach}$

- Teach for window function:

During the teach operation the window is set so that the current system pressure is in the middle of the window: $SP2 = \text{system pressure} + \frac{1}{2} \text{window width}$; $rP2 = \text{system pressure} - \frac{1}{2} \text{window width}$. Carry out teach operation \rightarrow 7.10.

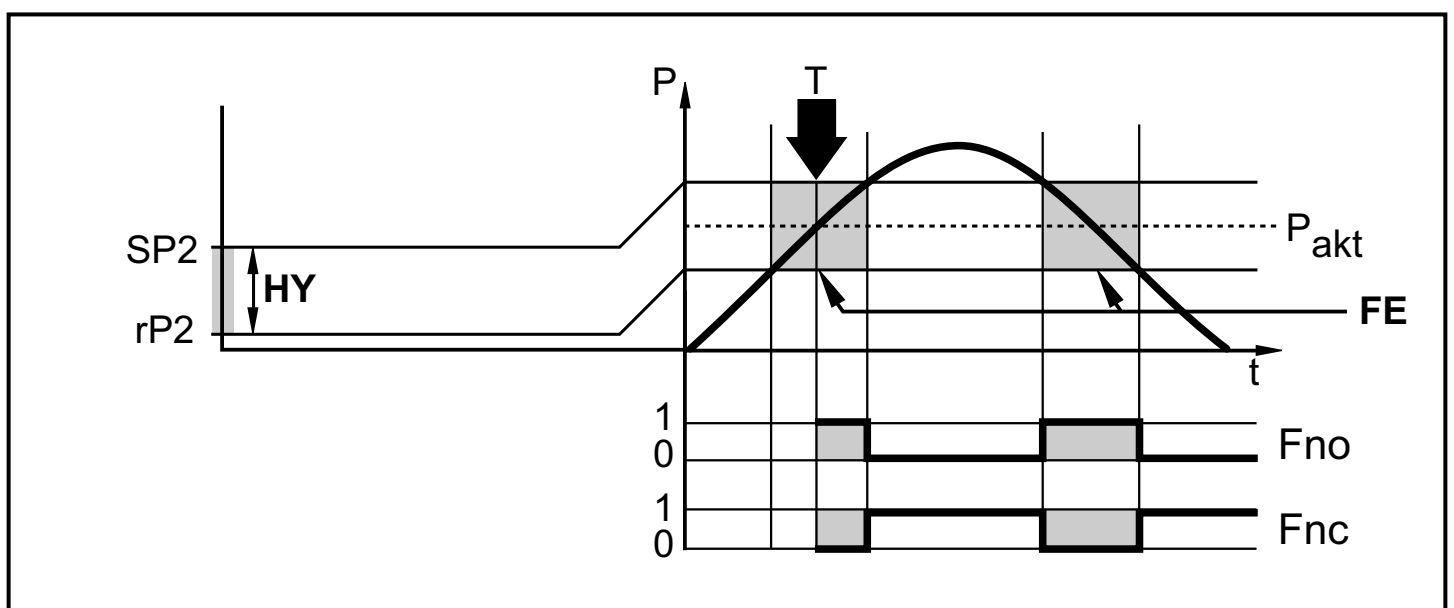

$P = \text{system pressure}$; $P_{akt} = \text{current system pressure}$; $FE = \text{window}$; $T = \text{time of teach}$

5 Installation



Before installing and removing the unit: Make sure that no pressure is applied to the system.

- ▶ Insert the unit in a G $\frac{1}{4}$ process connection.
- ▶ Tighten firmly. Recommended tightening torque: 25 Nm (max. 50 Nm).

6 Electrical connection



The unit must be connected by a qualified electrician.

The national and international regulations for the installation of electrical equipment must be adhered to.

Voltage supply to SELV, PELV.

- ▶ Disconnect power.
- ▶ Connect the unit as follows:

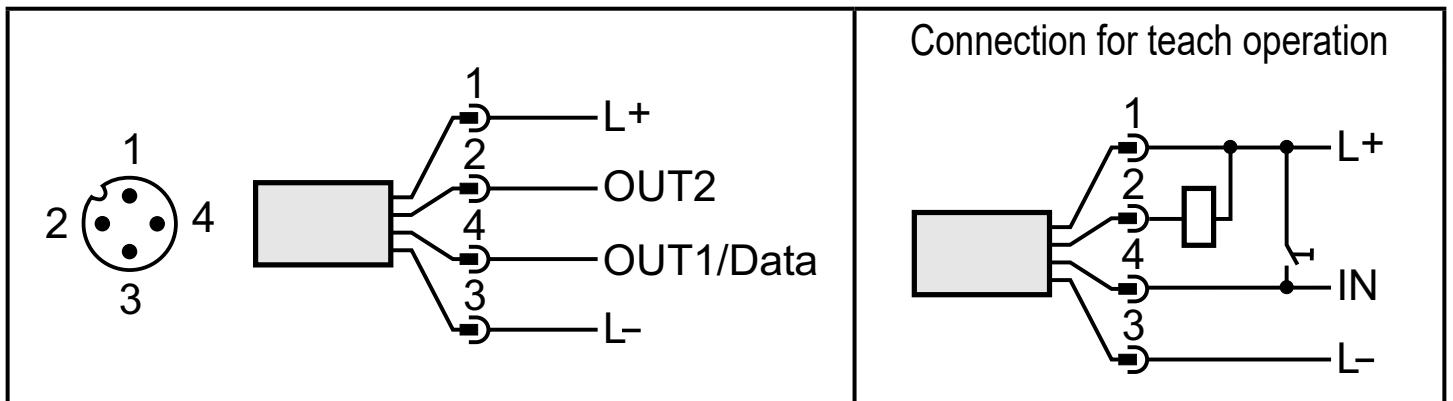

Pin 1	Ub+
Pin 3	Ub-
Pin 2 (OUT2)	<ul style="list-style-type: none"> • npn switching signal: limit values for pressure. • Diagnostic signal.
Pin 4 (OUT1/Data)	<ul style="list-style-type: none"> • npn switching signal: limit values for pressure. • Input for teach signal. • Data channel for bidirectional communication.

7 Parameter setting

Parameters can be set before installation and set-up of the unit or during operation.



If you change parameters during operation, the operating principle of the plant will be influenced.

► Ensure that there will be no malfunctions in your plant.

- Parameter setting with PP2001 → operating instructions enclosed to PP2001.
- Parameter setting with FDT service program ifm Container: The program has an intuitive graphical user interface.
- The program library of the available DTM objects can be found at www.ifm.com.

UK

7.1 Adjustable parameters

SP1/rP1	Upper / lower limit value for system pressure at which OUT1 switches.
SP2/rP2	Upper / lower limit value for system pressure at which OUT2 switches.
OU1	Output function for OUT1: - Switching signal for the limit values: hysteresis function or window function, either normally open or normally closed. - As an alternative: configure pin 4 as input for teach signal: [OU1] = [tch] .
OU2	Output function for OUT2: - Switching signal for the limit values: hysteresis function or window function, either normally open or normally closed. - As an alternative: configure OUT2 as diagnostic output: [OU2] = [dESI].
EF	Extended functions / opening of menu level 2.
Uni	Standard unit of measurement for system pressure.
HI	Maximum value memory for system pressure.
LO	Minimum value memory for system pressure (only for PP0524).
dS1/dS2	Switch-on delay for OUT1 / OUT2.
dr1/dr2	Switch-off delay for OUT1 / OUT2.
dAP	Measured value damping for filtering pressure peaks.
diS	Update rate for the measured value display / orientation of the display of PP2001.
TSP2	Triggers the teach function in the connected sensor.
Fnr	Fault memory (shows the last fault occurred).
rES	Restore factory setting.

7.2 Menu structure / display in PP2001

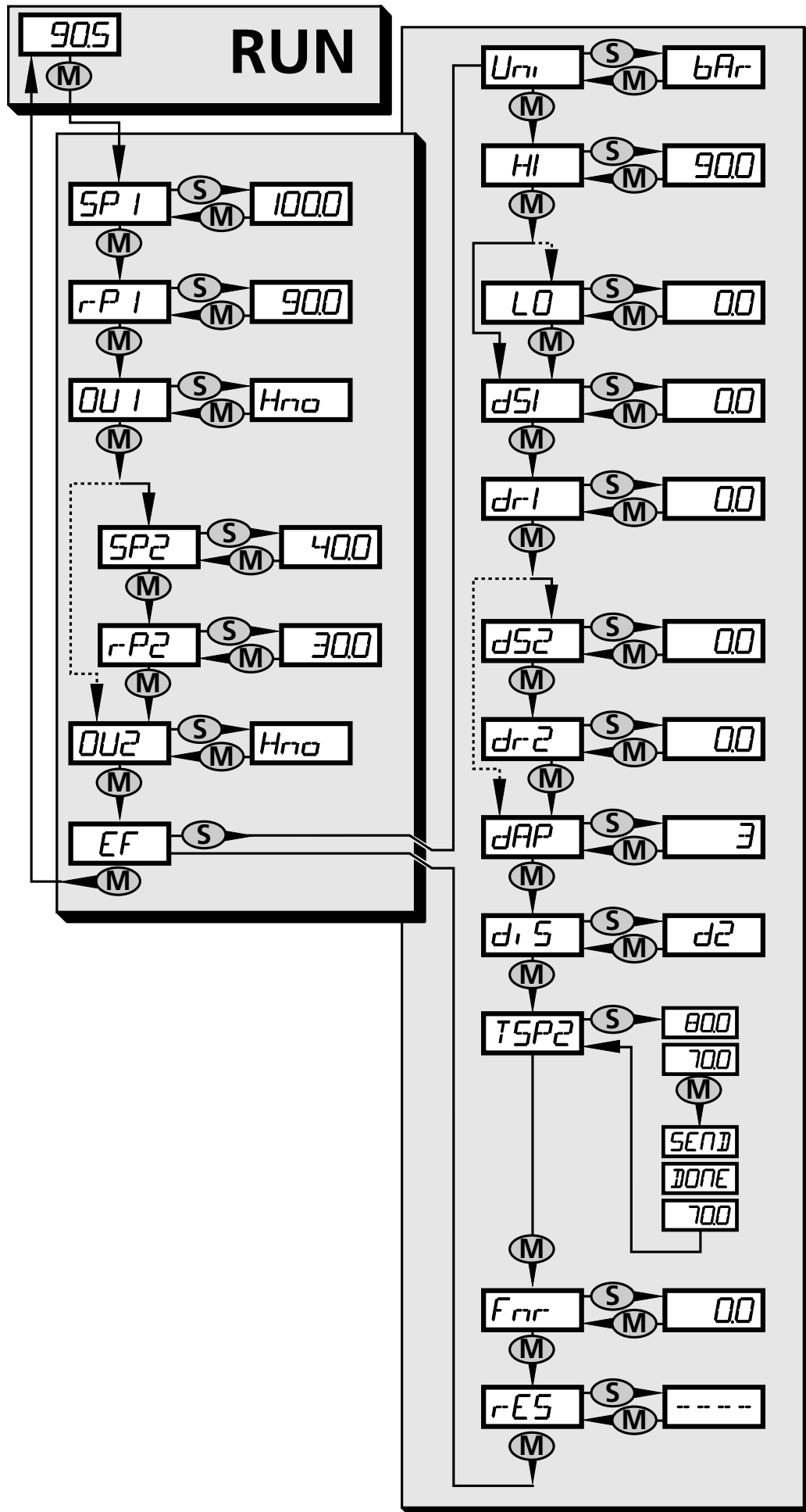



7.3 General parameter setting

- In case of parameter setting with the user interface of the ifm Container program, the values can be directly entered in the specified fields.
- For parameter setting with PP2001: Confirm each entry of a parameter value with [Mode/Enter].

7.3.1 Open menu level 2	
<p>With PP2001:</p> <ul style="list-style-type: none"> ▶ Select [EF]. ▶ Press [Set] briefly. If menu level 2 is protected by an access code, "Cod1" flashes in the display. ▶ Press [Set] and keep it pressed until the valid code no. is displayed. ▶ Press [Mode/Enter] briefly. <p>With the user interface of the program ifm Container:</p> <ul style="list-style-type: none"> ▶ Activate the [EF] button. If menu level 2 is protected by an access code, the input field for the code no. is activated. ▶ Enter valid code no. <p>On delivery by ifm electronic: no access restriction.</p>	

UK

7.4 Setting for operating mode 1 (2 switching outputs)

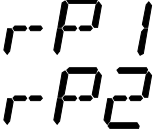
7.4.1 Setting of the output function	
<ul style="list-style-type: none"> ▶ Select [OU1] / [OU2] and set the function: [Hno] = hysteresis function/normally open [Hnc] = hysteresis function/normally closed [Fno] = window function/normally open [Fnc] = window function/normally closed 	
7.4.2 Setting of the switching limits	
<ul style="list-style-type: none"> ▶ Select [SP1] / [SP2] and set the value at which the output switches. 	
<ul style="list-style-type: none"> ▶ Select [rP1] / [rP2] and set the value at which the output switches off. rPx is always smaller than SPx. The unit only accepts values which are lower than the value for SPx. 	

7.5 Setting for operating mode 2 (switching output + teach input)

7.5.1 Configure pin 4 as teach input	
▶ Select [OU1] and set the function [tch].	OU 1
7.5.2 Setting of the output function for the switching output On delivery: [OU2] = [Hno] = hysteresis function/normally open. If necessary, change the output function as follows:	
▶ Select [OU2] and set the function: [Hno] = hysteresis function/normally open [Hnc] = hysteresis function/normally closed [Fno] = window function/normally open [Fnc] = window function/normally closed	OU2
7.5.3 Setting of the hysteresis / width of the window On delivery: hysteresis / window = 2 % of the final value of the measuring range If necessary, change it as follows:	
▶ Select [rP2] and set the smallest possible value (→ 10.1 Setting ranges for the set points / rP2 min). ▶ Select [SP2] and set the following value: rP min plus requested hysteresis / window width.	rP2 SP2

7.6 Setting for operating mode 3 (switching output + diagnostic output)

7.6.1 Setting of the output function for OUT 1	
▶ Select [OU1] and set the function: [Hno] = hysteresis function/normally open [Hnc] = hysteresis function/normally closed [Fno] = window function/normally open [Fnc] = window function/normally closed	OU 1
7.6.2 Setting of the switching limits	
▶ Select [SP1] and set the value at which the output switches.	SP 1
▶ Select [rP1] and set the value at which the output switches off. rPx is always smaller than SPx. The unit only accepts values which are lower than the value for SPx.	rP 1
7.6.3 Configure OUT2 as diagnostic output	
▶ Select [OU2] and set the function [dESI].	OU2

7.7 Setting for communication mode

For communication mode, no parameter setting is necessary. Using pin 4 (data channel), data can be read in and out at any time.



NOTE: voltage supply for communication mode: 18...32 V.

7.8 User settings (optional)

7.8.1 Setting of the unit of measurement for system pressure	
<p>► Select [Uni] and set the unit of measurement: [bAr], [MPa], [kPa] or [PSI]. To avoid rounding errors during internal conversion to other units: set the display unit before setting the values for the parameters SPx, rPX. On delivery: [Uni] = [bAr].</p>	
7.8.2 Setting of the update rate for the display	
<p>► Select [diS] and set the update rate of the display: [d1]: update of the measured values every 50 ms. [d2]: update of the measured values every 200 ms. [d3]: update of the measured values every 600 ms. [rd1], [rd2], [rd3]: display as for d1, d2, d3; rotated by 180°. [OFF]: The measured value display of PP2001 is deactivated in the operating mode.</p>	
7.8.3 Setting the switching delays	
<p>[dS1] / [dS2] = switch-on delay for OUT1 / OUT2. [dr1] / [dr2] = switch-off delay for OUT1 / OUT2. ► Select [dS1], [dS2], [dr1] or [dr2] and set a value between 0.2 and 50 s (at 0.0 the delay time is not active).</p>	
7.8.4 Setting of the damping of the measured value	
<p>► Select [dAP] and enter one of the specified values between 3 and 500 ms. dAP value = response time between pressure change and change of the switching status in seconds. [dAP] influences the switching frequency: $f_{\max} = 1 \div 2dAP$.</p>	

UK

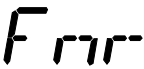
7.9 Service functions

7.9.1 Reading of the min/max values for system pressure	
<ul style="list-style-type: none"> ▶ Select [HI] or [LO], briefly press [Set]. [HI] = maximum value, [LO] = minimum value. <p>Erase the memory with PP2001:</p> <ul style="list-style-type: none"> ▶ Select [HI] or [LO]. ▶ Select [Set] and keep it pressed until [----] is displayed. ▶ Press [Mode/Enter] briefly. 	
7.9.2 Reading of the fault number	
<p>With PP2001:</p> <ul style="list-style-type: none"> ▶ Select [Fnr], briefly press [Set]. > The number of the last fault occurred is displayed. <p>For the fault numbers → 8.2 Fault indication</p> <p>With the user interface of the program ifm Container:</p> <ul style="list-style-type: none"> ▶ Activate the button [Fnr]. 	
7.9.3 Reset of all parameters to factory setting	
<p>With PP2001:</p> <ul style="list-style-type: none"> ▶ Select [rES], then press [Set] and keep it pressed until [----] is displayed. ▶ Press [Mode/Enter] briefly. <p>With the user interface of the program ifm Container:</p> <ul style="list-style-type: none"> ▶ Activate the button [rES]. <p>For the factory settings please refer to the end of these instructions (→ 11 Factory setting). We recommend taking down your own settings in that table before carrying out a reset.</p>	

7.10 Teach set point SP2

7.10.1 Teach with PP2001

- ▶ Establish the normal pressure in the plant (normal pressure = pressure at which the unit is to switch).
- ▶ Select [TSP2].
- ▶ Press [Set] and keep it pressed.
- > The current setting value for SP2 flashes for 5 s.
- > After 5 s, the current system pressure (= new value for SP2) is displayed.
- ▶ Press [Mode/Enter] briefly.
- > [SEND] is briefly displayed, then [DONE] and then the new setting value for SP2.

If the teach operation was not successful, [Err] is displayed after [SEND]. The setting for SP2 remains unchanged, the unit returns to the operating mode.

7 10.2 Teach by input signal on pin 4

- ▶ Establish the normal pressure in the plant (normal pressure = pressure at which the unit is to switch).
- ▶ Apply Ub+ to pin 4 for >2 ... < 5 s (T1).
- > One LED of the sensor flashes 2 Hz (┌┐┌┐).
- > After teaching the LED lights for 2 s (confirmation of successful teach operation).

In addition, the output function can be changed by a teach signal (NO → NC or NC → NO).

- ▶ Apply Ub+ to pin 4 for >5 ... < 10 s.
- > One LED of the sensor flashes 2 Hz (┌┐┌┐), after 5 s with a 1 Hz double flashing (┌┌┐┐).
- > After setting the LED lights for 2 s (confirmation of successful setting operation).

Fault during teach operation

The teach operation is cancelled in case of a fault. LED 1 flashes green/yellow at 8 Hz, the unit returns to the operating mode with unchanged values. Possible faults:

- Time error (teach time too long / too short).
- System pressure outside the measuring range.
- rP below the measuring range; window limit values outside the measuring range.

8 Operation

After power on, the unit is in the Run mode (= normal operating mode). It carries out its measurement and evaluation functions and provides output signals according to the set parameters.

8.1 Operation indication by LEDs

	LED 1	LED 2
Voltage supply	green	green
OUT1 = switched	yellow	green
OUT2 = switched	green	yellow
OUT1 and OUT2 = switched	yellow	yellow

8.2 Fault indication

No.	Type of fault	Display PP2001 FDT	LED indication	Diagnostic output (if activated)	Switching output
00	no fault		green or yellow	ON	according to process value and parameter setting
01	internal fault	[Err]	green 1 and 2 flashing (2 Hz)	switches OFF	switches OFF
02	parameter fault	[Err]	green 1 and 2 flashing (2 Hz)	switches OFF	switches OFF
03	clock error or malfunction in the sensor electronics	[Err]	green 1 and 2 flashing (2 Hz)	switches OFF	switches OFF
04	measuring range exceeded	[OL]	no fault response, green or yellow	ON	according to process value and parameter setting
05	value below measuring range	[UL]	no fault response, green or yellow	ON	according to process value and parameter setting
06	faulty operating voltage	[Err]	LED 1: green or yellow LED 2 passes from yellow to green for one second	OFF for at least 1 second	according to process value and parameter setting

9 Technical data

Operating voltage [V].....	9.6 ... 36 DC
Supply voltage for communication mode [V]	18 ... 32 DC
Current consumption [mA].....	< 45
Current rating [mA]	2 x 250
Short-circuit protection, pulsed, reverse polarity protection, overload protection	
Voltage drop [V].....	< 2
Power-on delay time [s].....	0.3
Min. response time [ms]	3 (for dAP = 0); default value: dAP = 60 ms
Switching frequency [Hz].....	170
Accuracy / deviations (in % of the span)	
- Set point accuracy	< ± 0.5
- Deviation of the characteristics	< ± 0.25 (BFSL) / < ± 0.5 (LS)
- Hysteresis	< ± 0.10
- Repeatability	< ± 0.10
- Long-term stability (in % of the span per year).....	< ± 0.10
- Temperature coefficients (TEMPCO) in the compensated temperature range	
0 ... 80°C (in % of the span / per 10 K)	
Greatest TEMPCO of the zero point / of the span.....	0.2 / 0.2
Materials (wetted parts).....	stainless steel (303), ceramics, FPM (Viton)
Housing materials.....	stainless steel (304); FPM (Viton); EPDM/X (Santoprene); PA
Protection rating	IP 68 *) / IP 69K
Protection class	III (SELV, PELV)
Insulation resistance [MΩ].....	> 100 (500 V DC)
Shock resistance [g].....	1000 (DIN/IEC 60068-2-27, DIN/IEC 60068-2-29) DIN EN 61373 category 3
Vibration resistance [g].....	20 (DIN/IEC 68-2-6, 10 - 2000 Hz) 14 (DIN EN 60068-2-64) DIN EN 61373 category 2
Switching cycles min.	100 million
Operating temperature [°C]	-25 ... 85
Medium temperature [°C]	-25 ... 90
Storage temperature [°C].....	-40 ... 100
Noise immunity to EN 61000-6-2	
EN 61000-4-2 ESD:	4 kV contact discharge / 15 kV air discharge
EN 61000-4-3 HF radiated:	20 V/m (80...1000 MHz)
EN 61000-4-4 Burst:	4 kV coupling clamp
EN 61000-4-5 Surge:	0.5 kV supply / 1 kV signal for DC units
EN 61000-4-6 HF conducted:	10 V (0.15...80 MHz)

*) 7 days / 1 m water depth / 0.1 bar

BFSL = Best Fit Straight Line / LS = Limit Value Setting

UK

9.1 Setting ranges for the set points

		SP1 / SP2		rP1 / rP2		ΔP
		min	max	min	max	
PP0520	bar	4	400	2	398	2
	PSI	60	5790	30	5760	30
	MPa	0.4	40.0	0.2	39.8	0.2
PP0521	bar	2	250	1	249	1
	PSI	40	3620	20	3600	20
	MPa	0,2	25,0	0,1	24,9	0,1
PP0522	bar	1.0	100.0	0.5	99.5	0.5
	PSI	20	1450	10	1440	10
	MPa	0.10	10.00	0.05	9.95	0.05
PP0523	bar	0.2	25.0	0.1	24.9	0.1
	PSI	4	362	2	360	2
	MPa	0.02	2.50	0.01	2.49	0.01
PP0524	bar	-0.90	10.00	-0.95	9.95	0.05
	PSI	-13	145	-14	144	1
	MPa	-0.090	1.000	-0.095	0.995	0.005

ΔP = step increment

10 Factory setting

	Factory setting	User setting
SP1	25% VMR *	
rP1	23% VMR *	
OU1	Hno	
SP2	75% VMR *	
rP2	73% VMR *	
OU2	Hno	
Uni	bAr	
dS1	0.0	
dr1	0.0	
dS2	0.0	
dr2	0.0	
dAP	60	
diS	d2	

* = the indicated percentage of the final value of the measuring range (VMR) of the corresponding sensor in bar is set