

Operating instructions
Diffuse reflection sensor with
background suppression and IO-Link

UK

OGH

80282421 / 00 08 / 2022

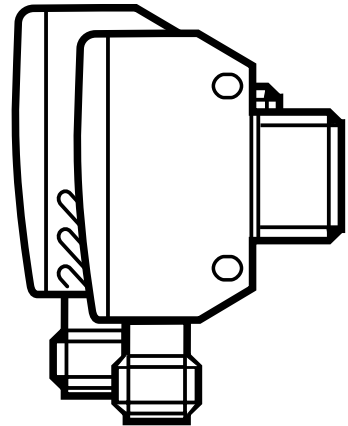

Contents

1 Preliminary note.....	3
1.1 Symbols used	3
2 Safety instructions	3
3 Functions and features	3
4 Installation.....	4
5 Electrical connection.....	4
5.1 PNP	4
5.2 NPN	5
6 Settings.....	5
6.1 Set via the sensor	5
6.1.1 Sensor is to switch when the object is detected	5
6.1.2 Sensor is not to switch when the object is detected	6
6.1.3 Set maximum sensitivity	6
6.1.4 Programming unsuccessful	6
6.1.5 Electronic lock	6
6.2 Set via IO-Link	6
6.2.1 Set range by means of background and object	7
6.2.2 Set range by means of background.....	8
6.2.3 Set maximum range	8
7 Operation.....	9
8 Maintenance, repair, disposal.....	9

1 Preliminary note

1.1 Symbols used

► Instructions

> Reaction, result

[...] Designation of keys, buttons or indications

→ Cross-reference



Information

Supplementary note.



Important note

Non-compliance may result in malfunction or interference.

UK

2 Safety instructions

- Read this document before setting up the product and keep it during the entire service life.
- The product must be suitable for the corresponding applications and environmental conditions without any restrictions.
- Only use the product for its intended purpose (→ 3 Functions and features).
- If the operating instructions or the technical data are not adhered to, personal injury and/or damage to property may occur.
- The manufacturer assumes no liability or warranty for any consequences caused by tampering with the product or incorrect use by the operator.
- Installation, electrical connection, set-up, operation and maintenance of the product must be carried out by qualified personnel authorised by the machine operator.
- Protect units and cables against damage.

3 Functions and features

The diffuse reflection sensor detects objects and materials without contact and indicates their presence by a switching signal.

For the range see the type label (on white paper 200 x 200 mm, 90 % remission).

4 Installation

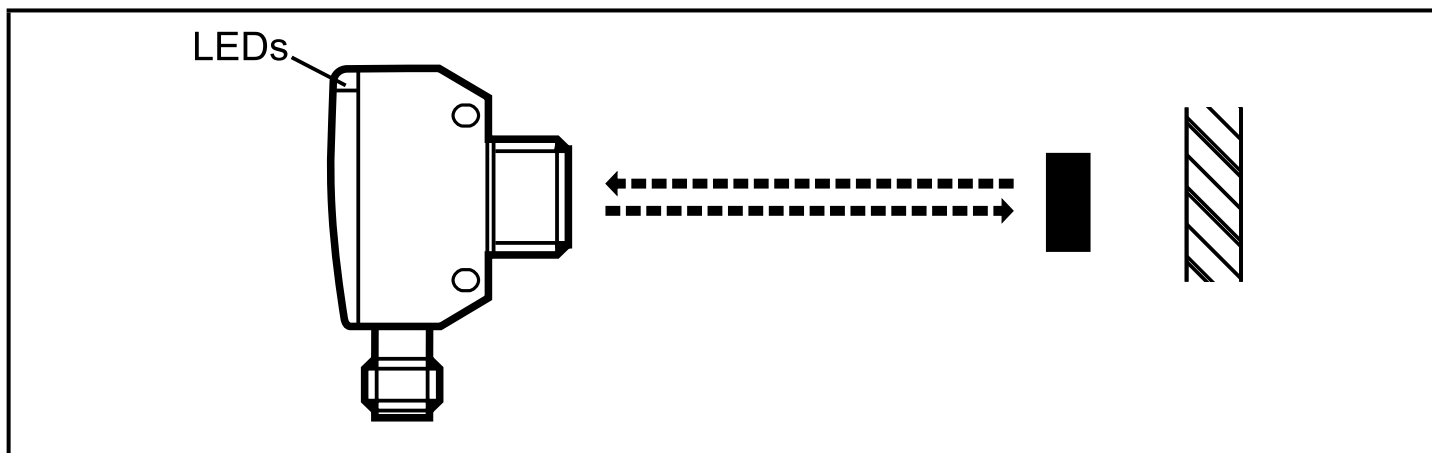

- ▶ Align the diffuse reflection sensor to the object to be detected and secure it to a bracket.

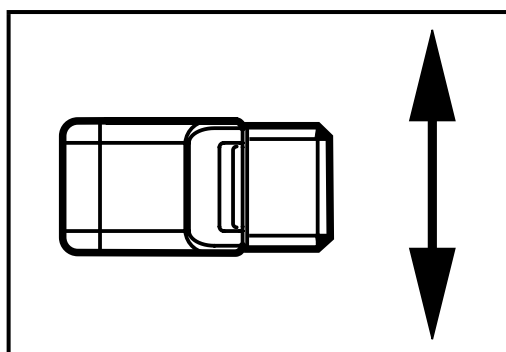

The objects to be detected should move transversely to the lens of the sensor. In case of other directions of movement it should be tested before whether the switching function is guaranteed.

5 Electrical connection



The unit must be connected by a qualified electrician.

- ▶ The national and international regulations for the installation of electrical equipment must be adhered to.
- ▶ Ensure voltage supply to EN 50178.
- ▶ Disconnect power.
- ▶ Connect the unit as follows:

5.1 PNP

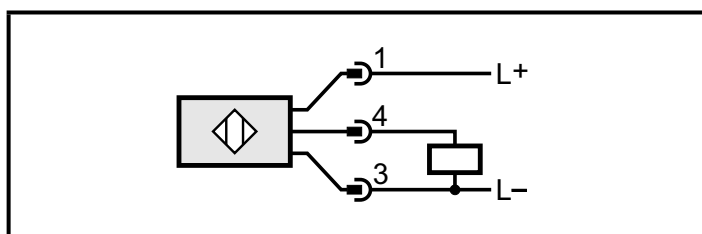

Pin 1 = L+ (10...30 V DC)

Pin 3 = L-

Pin 4 = load (PNP, 200 mA) / IO-Link
(Pin 2 = not connected)

5.2 NPN

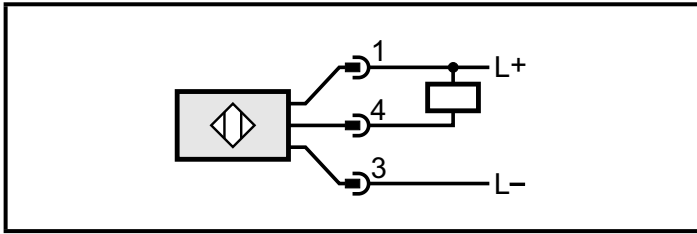

Pin 1 = L+ (10...30 V DC)

Pin 3 = L-

Pin 4 = load (NPN, 200 mA) / IO-Link
(Pin 2 = not connected)

6 Settings

6.1 Set via the sensor

6.1.1 Sensor is to switch when the object is detected

UK

1	<p>► Position the object.</p>
	<p>► Press [OUTon] for 2 s.</p> <p>> The sensitivity is set to the object.</p> <p>> The yellow LED flashes.</p>
2	<p>► Remove the object.</p>
	<p>► Press [OUToff].</p> <p>> The sensitivity is set without object.</p> <p>> The yellow LED goes out. Programming is completed.</p>

6.1.2 Sensor is not to switch when the object is detected

- ▶ Position the object (see fig. 1) and press [OutOff].
- ▶ Remove the object (see fig. 2) and press [OUTon].

The settings can also be carried out first without object and then with object.

6.1.3 Set maximum sensitivity

- ▶ Align the sensor so that no light is reflected.
 - > The sensor is to switch when the object is detected:
 - ▶ First press [OUTon] and then [OUToff].
 - > The sensor is to switch when the object is not detected:
 - ▶ First press [OUToff] and then [OUTon].

6.1.4 Programming unsuccessful

- > The LED flashes quickly, 8 Hz.
 - Measured value difference too small
 - Max. programming time (15 min.) exceeded.

6.1.5 Electronic lock

- ▶ Press [OUTon] and [OUToff] simultaneously for 10 s.
 - > Acknowledgement is indicated by a brief change of the LED status.

6.2 Set via IO-Link

This unit has an IO-Link communication interface which enables direct access to process and diagnostic data. In addition it is possible to set the parameters of the unit while it is in operation. Operation of the unit via the IO-Link interface requires an IO-Link master.

With a PC, suitable IO-Link software and an IO-Link adapter cable communication is possible while the system is not in operation.

The IODDs necessary for the configuration of the unit, detailed information about process data structure, diagnostic information, parameter addresses and the necessary information about the required IO-Link hardware and software can be found at www.ifm.com.

6.2.1 Set range by means of background and object

- ▶ Start the parameter setting software (e.g. moneo configure SA).
- ▶ Select [Parameter] > [Teach].
- ▶ Align the diffuse reflection sensor to the object (fig. 1).
- ▶ Click on the [Teach SP1 TP1] button in the parameter setting software.
- ▶ Align the diffuse reflection sensor to the background (fig. 2).
- ▶ Click on the [Teach SP1 TP2] button in the parameter setting software.
- > The switch point SP1 is between object and background (fig. 3).

UK

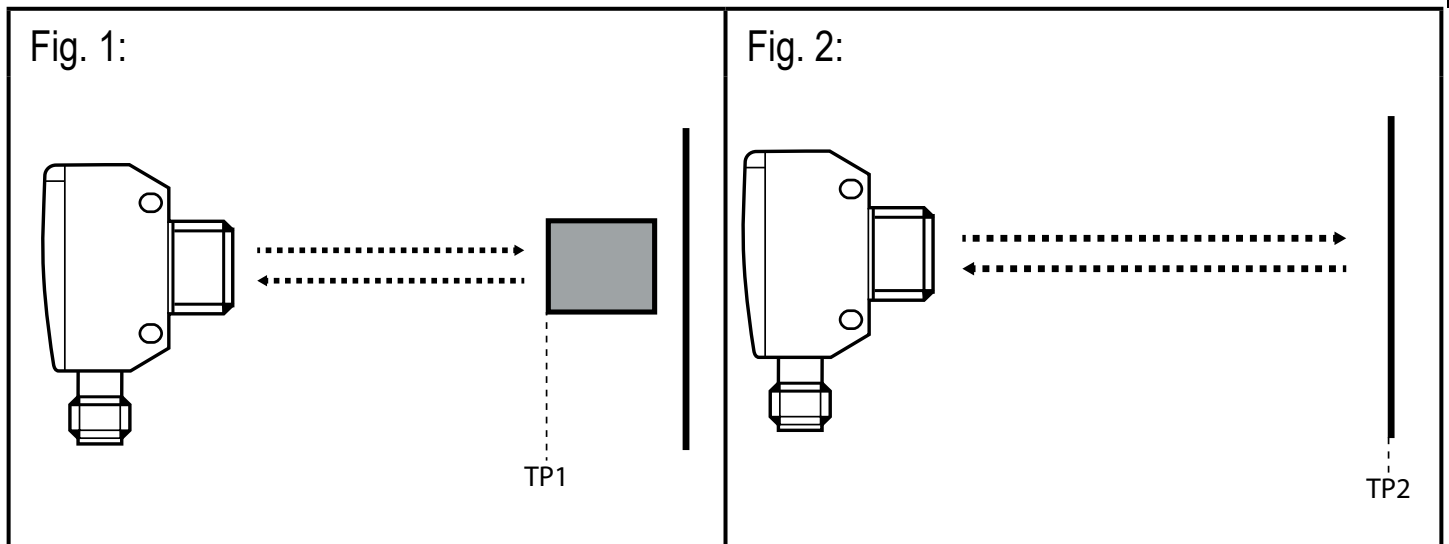

TP1: teach point 1

TP2: teach point 2

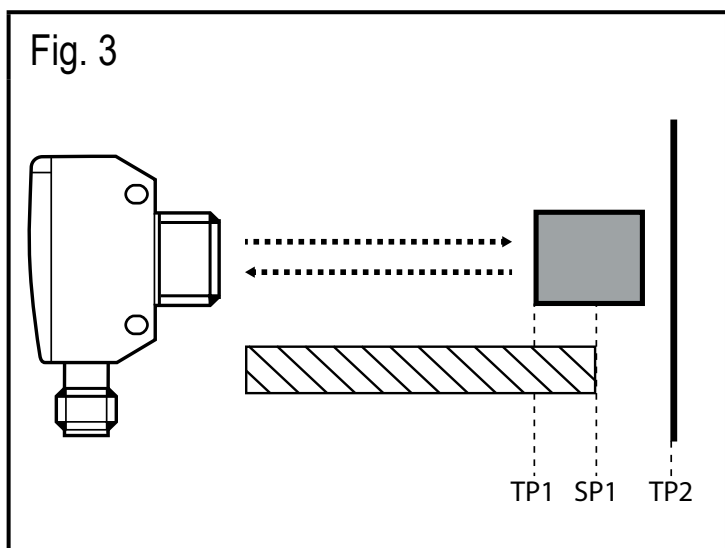

 Zone "object recognised"



Either the object can be set first and then the background, or the other way around.

6.2.2 Set range by means of background

If the object is not available, the range can be set using only the background.



The switching characteristics of the diffuse reflection sensor are most reliable if the range is set using the background and the object (→ 6.2.1).

- ▶ Start the parameter setting software (e.g. moneo configure SA).
- ▶ Click on the [Parameter] > [Teach].
- ▶ Align the diffuse reflection sensor to the background (fig. 4).
- ▶ Click on the [Teach Custom - SP1 without target] button in the parameter setting software.
- > The switch point SP1 is just in front of the background (fig. 5).

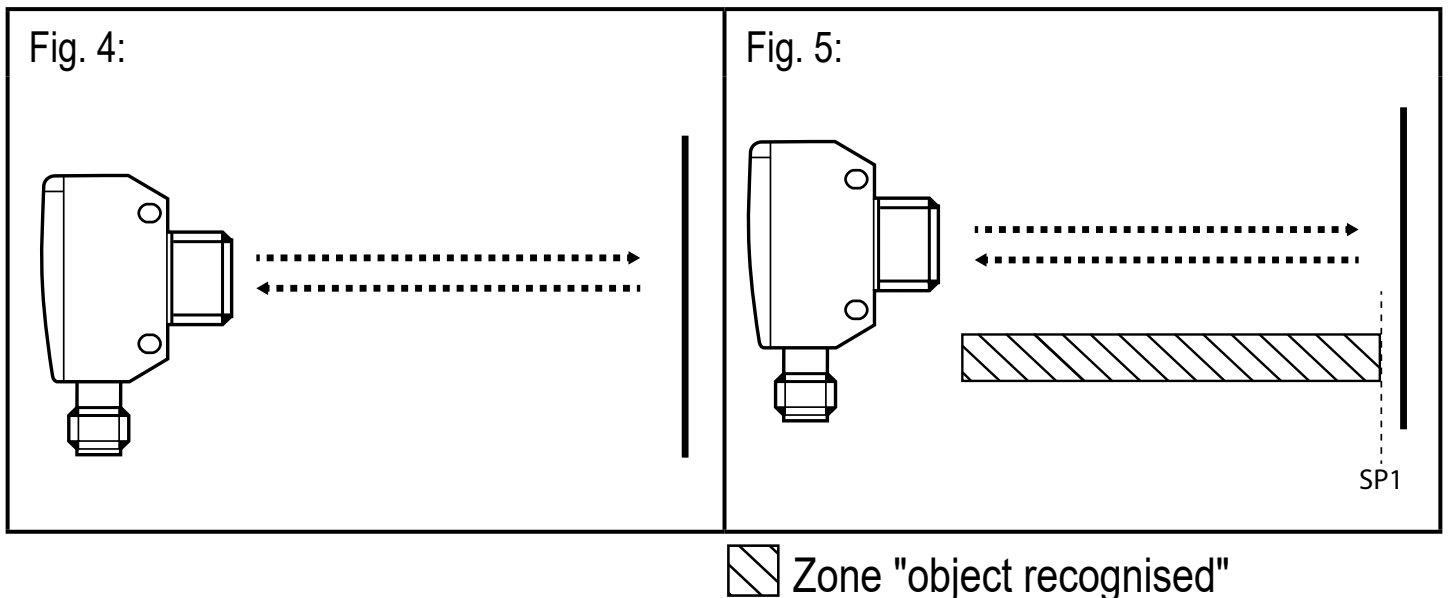

6.2.3 Set maximum range

- ▶ Start the parameter setting software (e.g. moneo configure SA).
- ▶ Select [Parameter] > [Teach].
- ▶ Align the diffuse reflection sensor to an empty area without object or background.
- > The diffuse reflection sensor must not receive any light from the object or the background.
- ▶ Click on the [Teach Custom - SP1 without target] button in the parameter setting software.

7 Operation

- ▶ Check whether the unit operates correctly.
- > The green LED is on when the unit is ready for operation.
- > The yellow LED is on when the switching output is switched.

8 Maintenance, repair, disposal

- ▶ Keep the lens of the sensor free from soiling.
- ▶ For cleaning do not use any solvents or cleaning agents which could damage the plastic parts.
- ▶ After use dispose of the unit in an environmentally friendly way in accordance with the applicable national regulations.

Faulty sensors must only be repaired by the manufacturer.

