

ifm electronic

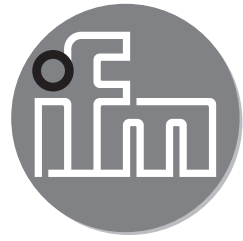

Operating instructions
Capacitive sensors

efectoriso[®]

KQ6

UK

704637 / 02 02 / 2010

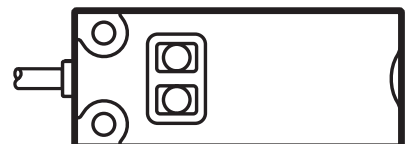

Contents

1 Preliminary note.....	3
1.1 Symbols used	3
2 Safety instructions	3
3 Functions and features	4
3.1 Application examples	4
4 Installation	5
4.1 Use as a level sensor	5
4.1.1 Installation on flat tanks with a mounting adapter	5
4.1.2 Mounting adapter bore hole dimensions	6
4.1.3 Installation on bypass pipes with a mounting adapter.....	6
4.2 Use as proximity sensor	7
4.2.1 Installation and installation remarks	7
4.2.2 Minimum distances	8
4.2.3 Sensor bore hole dimensions.....	8
4.3 Notes on laying of the connection cable	8
5 Electrical connection.....	8
5.1 Wiring.....	9
5.2 Unit versions with auto-detect.....	9
6 Operating and display elements	10
7 Settings.....	10
7.1 Basic teach empty state.....	10
7.2 Adjustment teach full state.....	11
7.3 Modified basic teach empty state	12
7.4 Locking / unlocking	13
8 Operation.....	13
9 Maintenance, repair, disposal.....	13
10 Approvals.....	13
11 Terms	14

1 Preliminary note

1.1 Symbols used

- Operating elements are indicated as follows:
Example: [OUT OFF] = Button “OUT OFF”.
- An instruction is indicated by “▶”.
Example: ▶ Mount the unit as shown.
- A reaction to the action is indicated by “>”.
Example: > Yellow LED on.



Important note

Non-compliance can result in malfunctions or interference.

2 Safety instructions

- Please read the product description prior to set-up of the unit. Ensure that the product is suitable for your application without any restrictions.
- The unit conforms to the relevant regulations and EC directives.
- Improper or non-intended use may lead to malfunctions of the unit or to unwanted effects in your application.
- That is why installation, electrical connection, set-up, operation and maintenance of the unit must only be carried out by qualified personnel authorised by the machine operator.

3 Functions and features

- capacitive sensor used as level or proximity sensor
- detects without contact metals, almost all plastics, glass, ceramics, wood, paper, oils, greases, water and all hydrous materials and indicates their presence by providing a switched signal
- automatic adjustment to the medium to be detected by means of programming buttons
- in level applications the sensor detects the medium through the tank wall (only suitable for non-metallic tanks)

3.1 Application examples

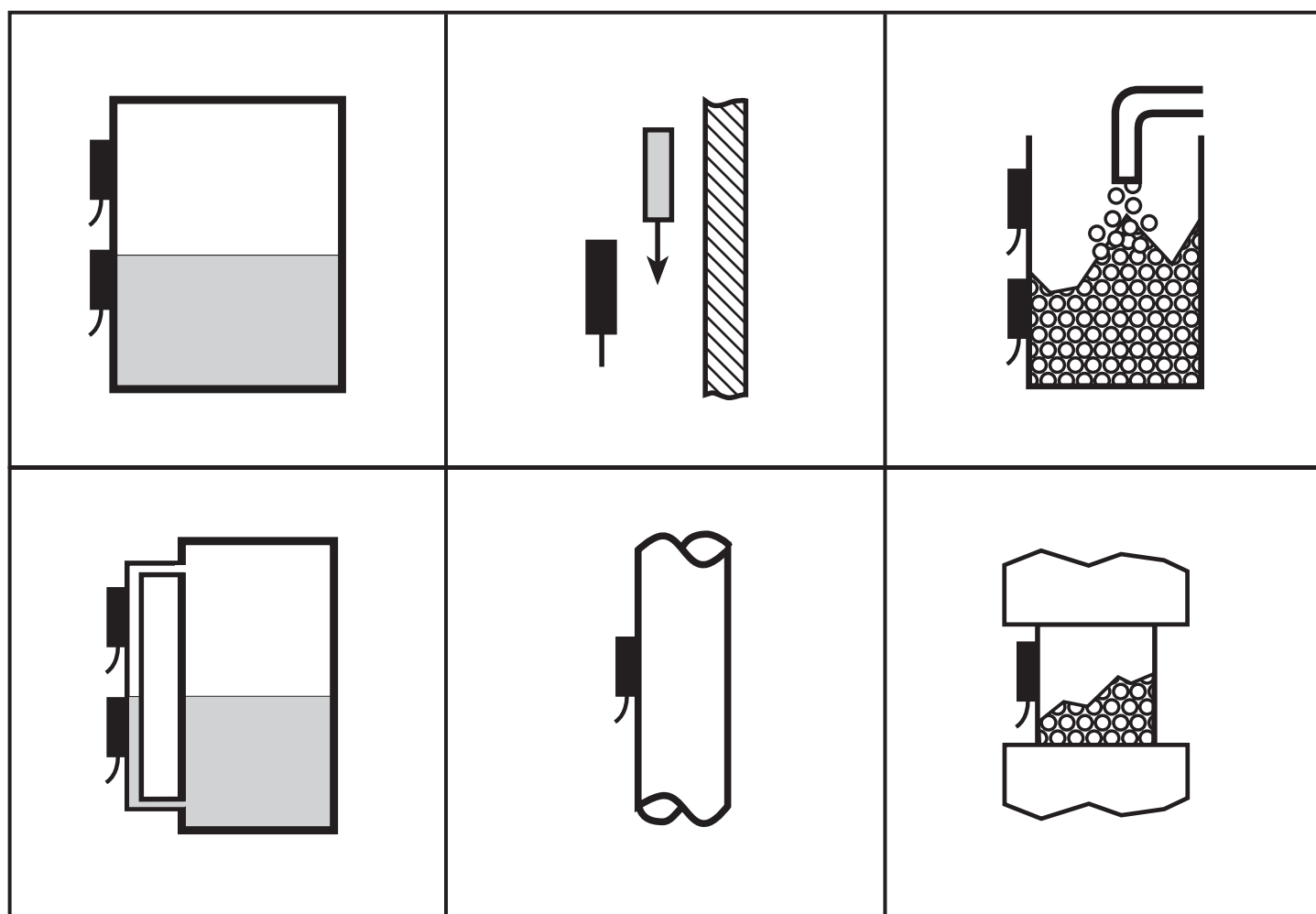

4 Installation

4.1 Use as a level sensor

4.1.1 Installation on flat tanks with a mounting adapter

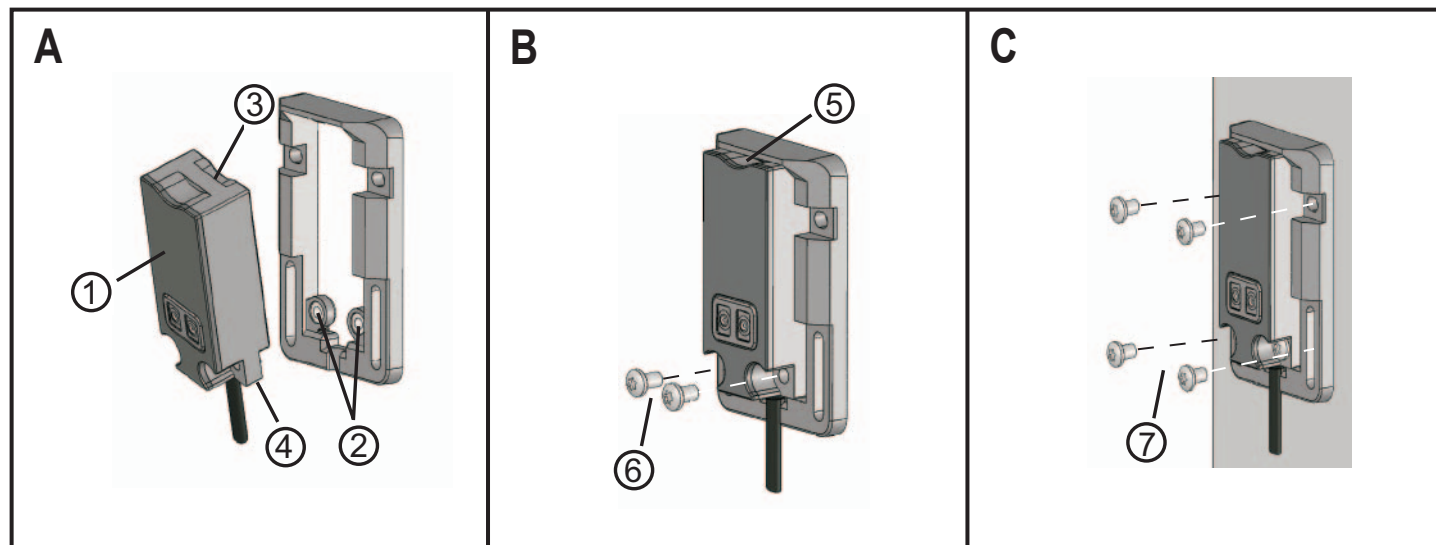

The mounting adapter is to be ordered separately (order no. E12153 pack quantity 1 piece or E12154 pack quantity 10 pieces).

Figure A

- ▶ Align the sensor (1), the cutouts (3) and (4) must show towards the mounting adapter.
- ▶ Place the sensor with the lower part into the mounting adapter. The sleeves of the mounting adapter (2) must engage with the lower cutouts of the sensor (4).
- ▶ First slightly press the lower part of the sensor.
- ▶ When the lower part of the sensor is well placed, completely press the sensor into the mounting adapter.
- > You can hear the sensor snap in.

Figure B

- > The catch of the mounting adapter (5) must engage with the sensor.
- ▶ Fix the sensor with the enclosed screws (6) to the adapter.

Figure C

- ▶ Fix the mounting adapter including the inserted sensor to the tank at the requested height using suitable screws (7).

4.1.2 Mounting adapter bore hole dimensions

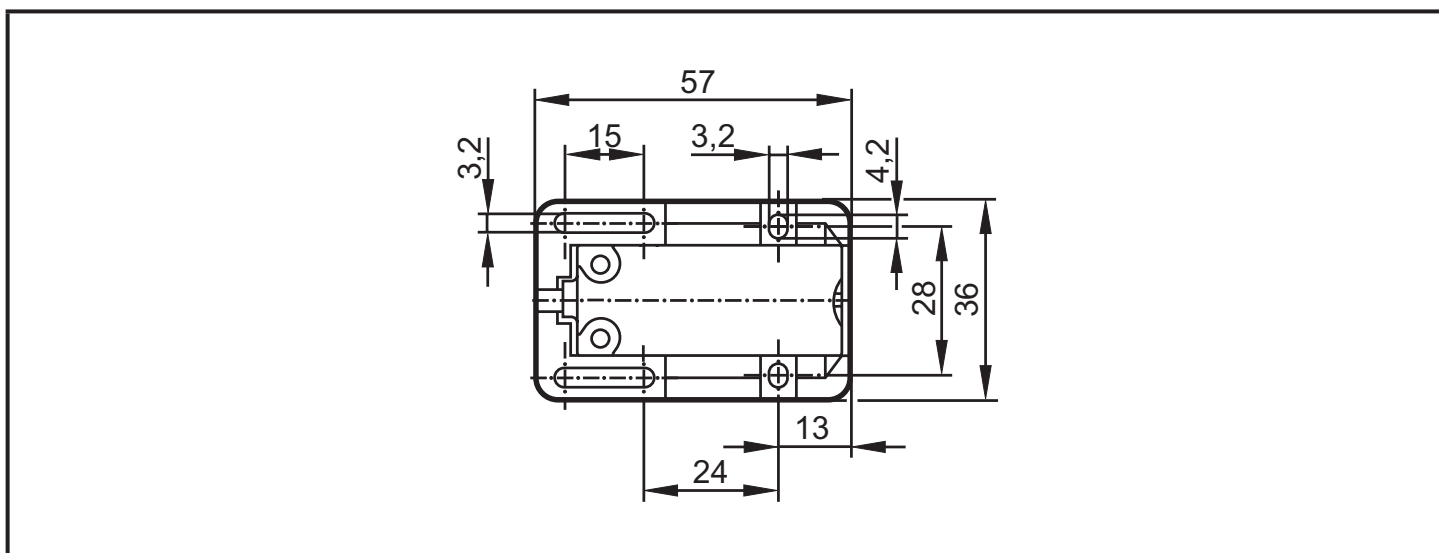

 Do not place the mounting adapter including inserted sensor in the immediate vicinity of metallic objects.

4.1.3 Installation on bypass pipes with a mounting adapter

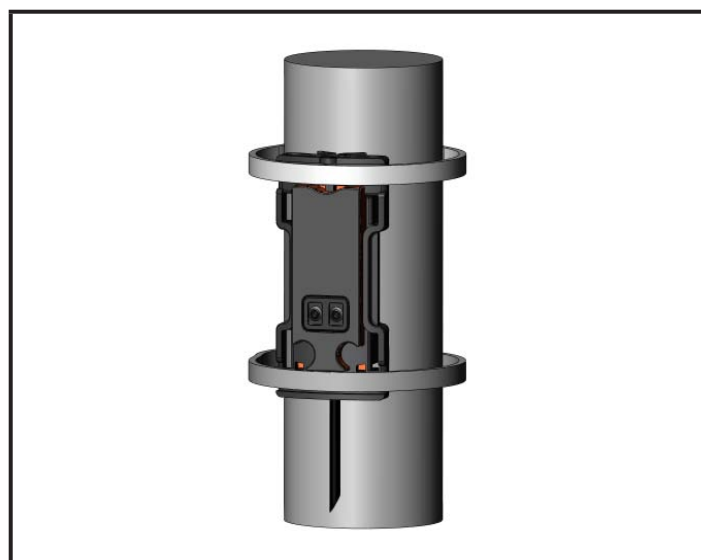

The mounting adapter is to be ordered separately (order no. E12163 pack quantity 1 piece).

- ▶ Fix the sensor to the bypass at the requested height with common cable ties.
- ▶ Insert the cable ties through the existing openings of the mounting adapter and tighten them firmly.

4.2 Use as proximity sensor

4.2.1 Installation and installation remarks

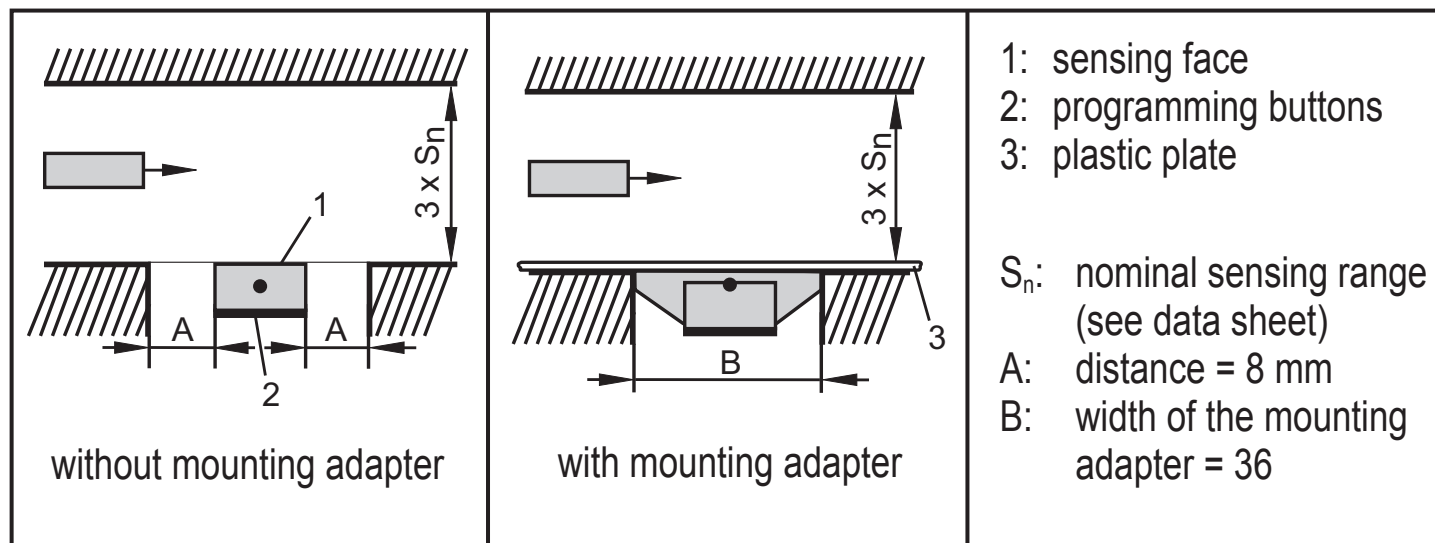

- ▶ Align the sensing face (1) to the object. Make sure that the programming buttons (2) remain accessible.
- ▶ Adhere to the indicated minimum distances to metallic objects opposite and beside the sensor (free space).
- ▶ Non-metallic objects (e.g. plastic fixtures) are allowed within the lateral free space.
- ▶ Fix the sensor with appropriate fixing screws to the designated location.
- ▶ If the sensor is installed behind a plastic plate (3), the object will be detected through the wall. Depending on the material used and the wall thickness the sensor characteristics might change slightly. Do not use conductive plastics! If possible, use thin walls.

4.2.2 Minimum distances

Installation of several sensors of the same type

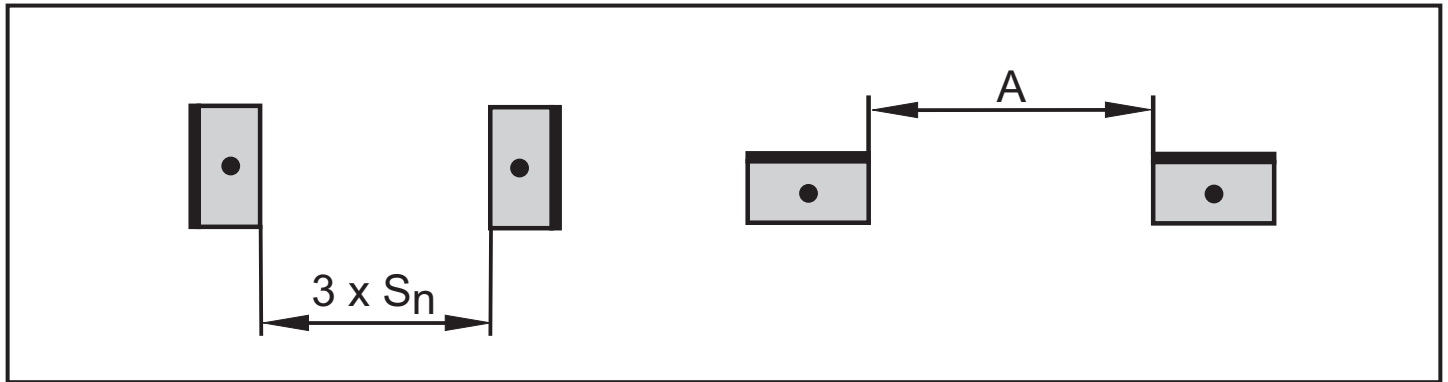

S_n : nominal sensing range (see data sheet)

A: sensor distance 50 mm

4.2.3 Sensor bore hole dimensions

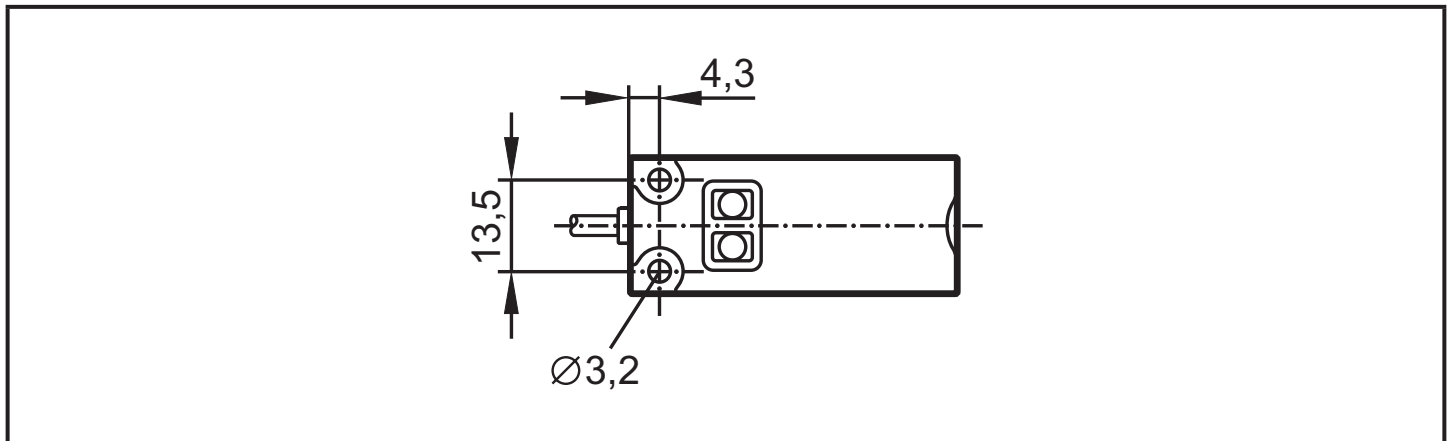

4.3 Notes on laying of the connection cable

- Lay the cable as straight as possible and do not coil it.
- If necessary, cut the cable to the required length.

5 Electrical connection



The unit must be connected by a qualified electrician.

The national and international regulations for the installation of electrical equipment must be adhered to.

- Disconnect power
- Connect the unit

5.1 Wiring

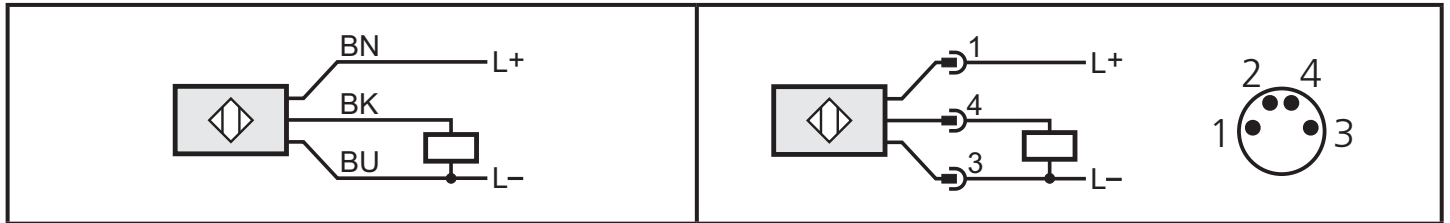

p-switching (type ...FPKG... or ...FPOG...)

BN = brown, BK = black, BU = blue

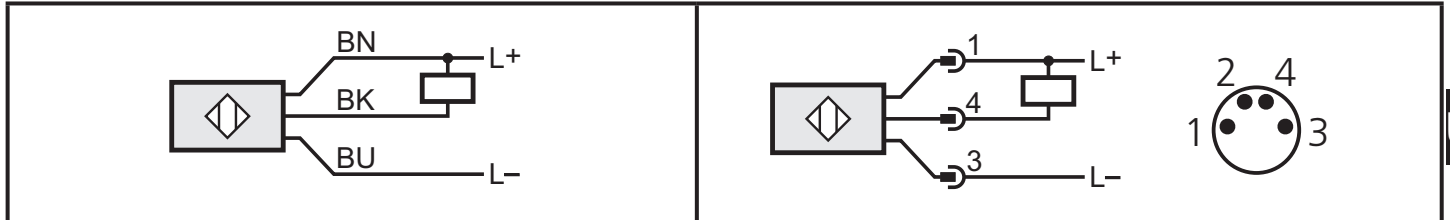

n-switching (type ...FNKG... or ...FNOG...)

BN = brown, BK = black, BU = blue

5.2 Unit versions with auto-detect

On power up, unit types with auto-detect (types ...FAKG or ...FAOG...) detect automatically if the output is connected to L- (p switching) or to L+ (n switching).

► Disconnect the unit to acknowledge a change of the load connection.



Automatic load detection is only ensured when a resistor is switched in series to a **closed** mechanical contact.



6 Operating and display elements

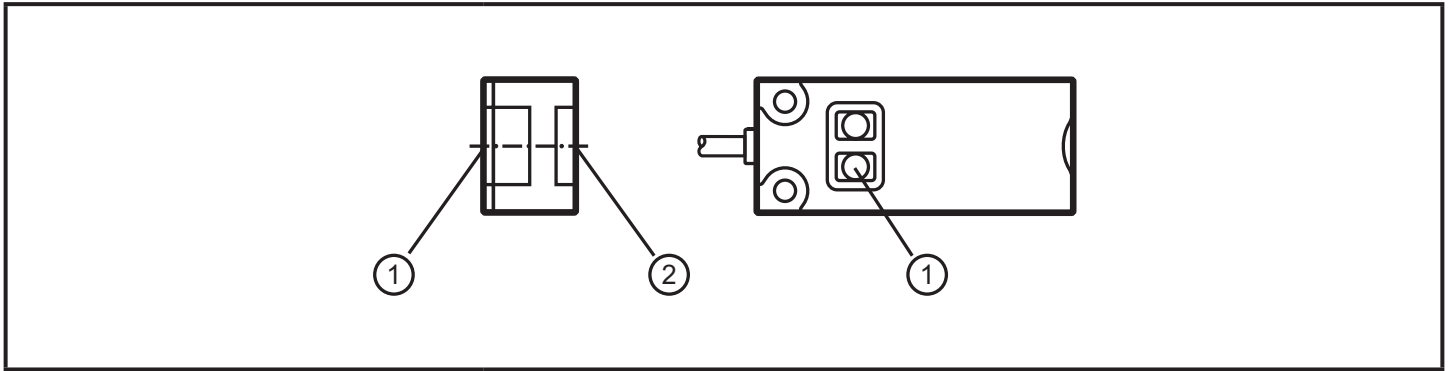

1: programming buttons

2: sensing face

7 Settings

7.1 Basic teach empty state

Using the basic teach empty state the unit suppresses the installation environment. The basic teach empty state resets the unit, an adjustment teach already carried out is deleted.

<p>▶ Empty the tank until the level is at least 20 mm below the sensor.</p>	
<p>Set the unit as normally open (output closes when the tank is full):</p> <p>▶ Press [OUT OFF] for min. 2 s (max. 6 s).</p> <p>> While pressing the pushbutton the LED flashes slowly. After releasing the pushbutton, the LED goes out.</p>	
<p>Set the unit as normally closed (output opens when the tank is full):</p> <p>▶ Press [OUT ON] for min. 2 s (max. 6 s).</p> <p>> While pressing the pushbutton the LED flashes slowly. After releasing the pushbutton, the LED lights continuously.</p>	

The unit is now ready for operation. For the detection of media with a low dielectric constant (e.g. plastic granulates or oils) no further setting is required.

7.2 Adjustment teach full state

Necessary for aqueous media. The sensitivity of the unit is optimised. Later on, the adjustment teach full state can be repeated at any time, an adjustment teach empty state already carried out is not affected.

A basic teach empty state must be carried out prior to the adjustment teach full state (→ chapter 7.1 Basic teach empty state)! If it is not possible to empty the tank, a basic teach empty state can be carried out by simulating the empty state (e.g. adjustment when not installed, adjustment at a higher position). For optimum function it is necessary to carry out the “modified basic teach empty state” (→ chapter 7.3 Modified basic teach empty state) when the tank is emptied the next time.

UK

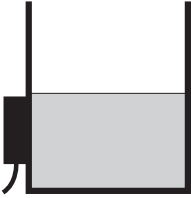
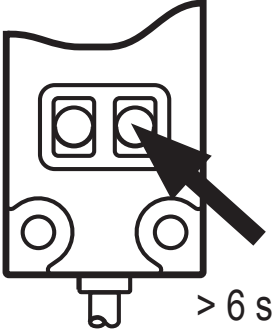
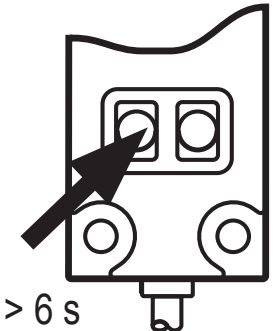
<ul style="list-style-type: none">▶ Fill the tank until the sensing face of the unit is covered.> For NO the LED lights, for NC it goes out.	
<p>Set the unit as normally open (output closes when the tank is full):</p> <ul style="list-style-type: none">▶ Press [OUT ON] for min. 6 s.> While pressing the pushbutton the LED first flashes slowly, after 6 s more quickly. After releasing the pushbutton, the LED lights continuously.	
<p>Set the unit as normally closed (output opens when the tank is full):</p> <ul style="list-style-type: none">▶ Press [OUT OFF] for min. 6 s.> While pressing the pushbutton the LED first flashes slowly, after 6 s more quickly. After releasing the pushbutton, the LED goes out.	

7.3 Modified basic teach empty state

Recommended for deposits in the tank. Deposits are largely suppressed. This is also recommended if it has not been possible to carry out a basic teach empty state (e.g. if the sensor is set up on a full tank; details: → chapter 7 Adjustment teach full state)

Later on, the modified basic teach empty state can be repeated at any time, an adjustment teach full state already carried out is not affected.

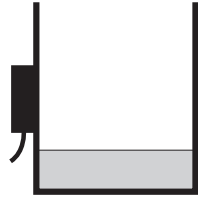
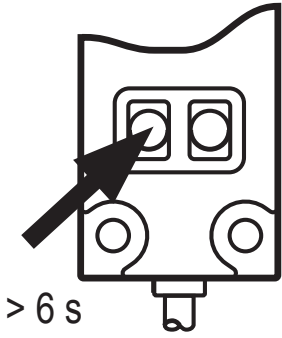
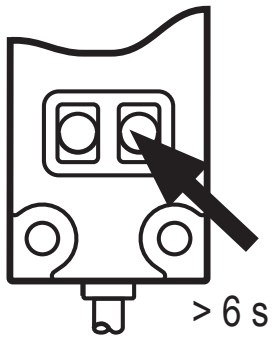
<ul style="list-style-type: none">▶ Empty the tank until the level is below the sensing face of the unit.> For NO the LED goes out, for NC the LED lights.	
<p>Set the unit as normally open (output closes when the tank is full):</p> <ul style="list-style-type: none">▶ Press [OUT OFF] for min. 6 s.> While pressing the pushbutton the LED first flashes slowly, after 6 s more quickly. After releasing the pushbutton, the LED goes out.	
<p>Set the unit as normally closed (output opens when the tank is full):</p> <ul style="list-style-type: none">▶ Press [OUT ON] for min. 6 s.> While pressing the pushbutton the LED first flashes slowly, after 6 s more quickly. After releasing the pushbutton, the LED lights continuously.	

7.4 Locking / unlocking

The unit can be electronically locked to protect it against unintentional setting.

- ▶ To lock press [**OUT ON**] and [**OUT OFF**] **simultaneously** for 10 s.
- > Acknowledgement: LED state (yellow) changes for a short time (the lit LED goes out briefly or the LED which is not lit lights briefly).
- ▶ To unlock repeat this step.

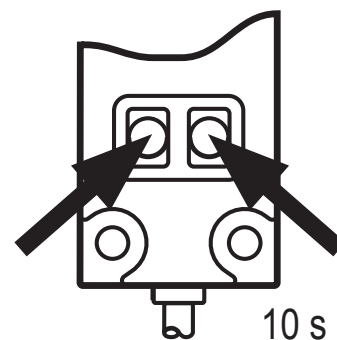

UK

If the unit does not react, it may be locked.

8 Operation

Check whether the unit operates correctly. Bring about a sensor response by taking suitable measures.

Display by LEDs (independent of the programmed output function):

LED yellow OFF:	switching output disabled
LED yellow ON:	switching output enabled

9 Maintenance, repair, disposal

The operation of the unit is maintenance-free. To ensure a correct function:

- Keep the sensing face and a clear space, if any, free from deposits and foreign bodies.

When replacing the sensor ensure that installation is done in the same way and a sensor with the same settings is used.

It is not possible to repair the unit.

After use dispose of the unit in an environmentally friendly way in accordance with the applicable national regulations.

10 Approvals

The device shall be supplied from an isolating transformer having a secondary Listed fuse rated 1.0 A.

11 Terms

Active zone

Area above the sensing face in which the sensor reacts to the approach of the target.

Output function

Normally open: object within the active zone - output switched.

Normally closed: object within the active zone - output blocked.

Programmable: Choice between normally closed or normally open.

Positive switching: positive output signal (to L-).

Negative switching: negative output signal (to L+).

Power-on delay time

The time the sensor needs to be ready for operation after application of the operating voltage (in the millisecond range).

Hysteresis

Difference between the switch-on and the switch-off point.

Leakage current

Current for the internal supply of 2-wire units, also flows through the load when the output is blocked.

Current consumption

Current for the internal supply of 3-wire DC units.

Switch point drift

Shifting of the switch point owing to changes of the operating conditions (e.g. temperature, pressure, air humidity).

Short-circuit protection

ifm sensors which are protected against excessive current by means of a pulsed short-circuit protection. The inrush current of incandescent lamps, electronic relays and low resistance loads may cause this protection to cut in and turn the sensor off!

Operating voltage

The voltage range in which the sensor functions safely. A stabilised and smoothed direct voltage should be used! Take into account residual ripple!

