



CE

Operating instructions
Pressure sensor

PN78xx
PY7809

UK

11450550 / 00 08 / 2020

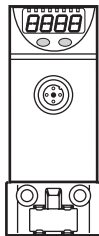

Contents

1	Preliminary note.....	3
1.1	Symbols used.....	3
2	Safety instructions	4
3	Functions and features	5
4	Function.....	6
4.1	Processing of the measured signals.....	6
4.2	Switching function.....	6
4.3	Diagnostic function	7
4.4	Differential pressure measurement.....	7
5	Mounting.....	8
5.1	Mounting accessories.....	8
5.2	Pressure connections for differential pressure measurement.....	8
5.3	DIN rail mounting.....	9
5.4	Rear panel mounting	9
5.5	Mounting on a pressure-carrying rear panel.....	10
5.6	Floor mounting.....	11
5.7	Mounting on a maintenance unit	12
6	Electrical connection.....	13
7	Operating and display elements	14
8	Menu.....	15
8.1	Menu structure.....	15
8.2	Explanation of the menu.....	16
9	Parameter setting	17
9.1	General parameter setting.....	17
9.2	Setting of the output signals	19
9.2.1	Setting of the unit of measurement for system pressure	19
9.2.2	Setting of the output function.....	19
9.2.3	Setting of the switching limits	19
9.3	User settings (optional)	19
9.3.1	Setting of a time delay for the switching signals.....	19
9.3.2	Setting of the output logic for the switching outputs.....	20

9.3.3	Setting of the damping for the switching outputs	20
9.3.4	Configuration of the display	20
9.3.5	Zero point calibration	21
9.4	Service functions	22
9.4.1	Reading of the min/max values for system pressure.....	22
9.4.2	Reset of all parameters to factory setting	22
10	Operation	22
10.1	Reading of the set parameters	22
10.2	Fault indication	22
10.3	Setting ranges	23
11	Factory setting	24

1 Preliminary note

1.1 Symbols used

▶ Instruction

> Reaction, result

[...] Designation of keys, buttons or indications

→ Cross-reference



Important note

Non-compliance may result in malfunction or interference



Information

Supplementary note

2 Safety instructions

- The device described is a subcomponent for integration into a system.
 - The manufacturer is responsible for the safety of the system.
 - The system manufacturer undertakes to perform a risk assessment and to create documentation in accordance with legal and normative requirements to be provided to the operator and user of the system. This documentation must contain all necessary information and safety instructions for the operator, the user and, if applicable, for any service personnel authorised by the manufacturer of the system.
- Read this document before setting up the product and keep it during the entire service life.
- The product must be suitable for the corresponding applications and environmental conditions without any restrictions.
- Only use the product for its intended purpose (→ Functions and features).
- Only use the product for permissible media (→ Technical data).
- If the operating instructions or the technical data are not adhered to, personal injury and/or damage to property may occur.
- The manufacturer assumes no liability or warranty for any consequences caused by tampering with the product or incorrect use by the operator.
- Installation, electrical connection, set-up, programming, configuration, operation and maintenance of the product must be carried out by personnel qualified and authorised for the respective activity.
- Protect units and cables against damage.

3 Functions and features

The unit monitors the system pressure in pneumatic and compressed air networks of machines and plants.

Applications

Compressed air (other media on request)

Type of pressure: relative pressure

Order no.	Measuring range		Permissible overpressure		Bursting pressure	
	bar	PSI	bar	PSI	bar	PSI
PN7834	-1...10	-14.5...145	20	290	30	435
	mbar	PSI	mbar	PSI	mbar	PSI
PN7809 PY7809	-1 000...1 000	-14.5...14.5	20 000	290	30 000	435

MPa = bar ÷ 10 / kPa = bar × 100



Avoid static and dynamic overpressure exceeding the given overload pressure by taking appropriate measures.

The indicated bursting pressure must not be exceeded.

Even if the bursting pressure is exceeded only for a short time, the unit may be destroyed. NOTE: Risk of injury!



Pressure Equipment Directive (PED):

The units comply with the Pressure Equipment Directive and are designed and manufactured for group 2 fluids in accordance with the sound engineering practice. Use of group 1 fluids on request!

If pressures might occur which are higher than the permissible overpressure, you should use other units of the PN70xx series. If you have any questions, please contact ifm electronic's sales specialists.

4 Function

4.1 Processing of the measured signals

- The unit displays the current system pressure.
- It generates 2 output signals according to the parameter setting.

OUT1	• Switching signal for system pressure limit value.
OUT2	2 options • Switching signal for system pressure limit value. • Diagnostic signal (output 1 is inactive in case of a fault).

4.2 Switching function

OUTx changes its switching state if it is above or below the set switching limits (SPx, rPx). The following switching functions can be selected:

- Hysteresis function / normally open: [OUx] = [Hno] (→ fig. 1).
- Hysteresis function / normally closed: [OUx] = [Hnc] (→ fig. 1).

First the set point (SPx) is set, then the reset point (rPx) with the requested difference.

- Window function / normally open: [OUx] = [Fno] (→ fig. 2).
- Window function / normally closed: [OUx] = [Fnc] (→ fig. 2).

The width of the window can be set by means of the difference between SPx and rPx. SPx = upper value, rPx = lower value.

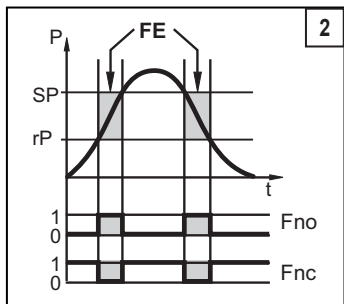
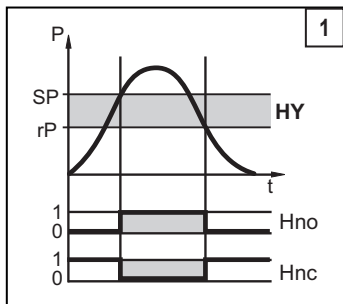

P = system pressure; HY = hysteresis; FE = window

4.3 Diagnostic function

Output 2 is used as diagnostic output based on the DESINA specification if [OU2] = [dESI].

- If there is no fault, the output is switched and carries UB+ (if P-n = PnP) or UB- (if P-n = nPn).
- In case of malfunctions in the following areas, the output is inactive:
 - short circuit in output 1.
 - EPROM function.
 - RAM function.
 - parameter setting.
 - processor function.

UK

4.4 Differential pressure measurement

Besides the main pressure connection (1) the unit provides a ventilation connection (2). If both connections are connected to the pressure system, the unit can work as a differential pressure sensor.

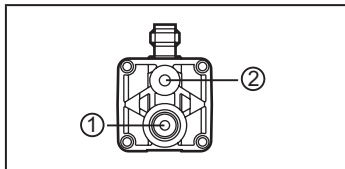

For proper function the following conditions must be met:

- The pressure at the main connection must always be greater than the pressure at the ventilation connection.
- However, the pressure at the ventilation connection must not exceed 10 bar.

Note:

For differential pressure measurement the measurement accuracy deviates from the specified accuracy (→ 12 Technical data). The deviation depends on the amount of system pressure. It is 3.5 to 8.3 mbar per 1 bar system pressure.

The deviation can be minimised by setting an offset value (→ 9.3.5 Zero point calibration).

5 Mounting



Before installing and removing the unit: make sure that no pressure is applied to the system.

- ▶ Screw the pressure connection or adapter $G\frac{1}{8}$ to the main pressure connection (1) and tighten. Maximum tightening torque: 8 Nm.

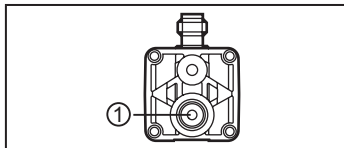

Further possibilities: → the following sections.

5.1 Mounting accessories

The following components are available as accessories:

	Order no.
Mounting set for DIN rail mounting (DIN rail TH 35-7.5 to EN 60715)	E37340
Adapter $R\frac{1}{8}$ to $R\frac{1}{8}$, can be aligned	E37350
T pipe mounting set, includes: <ul style="list-style-type: none">• T pipe with 3 connections $G\frac{1}{2}$• Reducer $G\frac{1}{2}$ to $G\frac{1}{8}$• Adapter $R\frac{1}{8}$ to $R\frac{1}{8}$	E37360
Thread extension $1/8"$ for flange mounting	E30075
Push-in air fitting for tube \varnothing 6 mm	E30076
Push-in air fitting for tube \varnothing 8 mm	E30077

5.2 Pressure connections for differential pressure measurement

- ▶ Remove the label from the ventilation connection M5 (2), connect to the pressure system. Maximum tightening torque: 2.5 Nm.
- ▶ Connect the main pressure connection $G\frac{1}{8}$ (1) to the pressure system. Maximum tightening torque: 8 Nm.

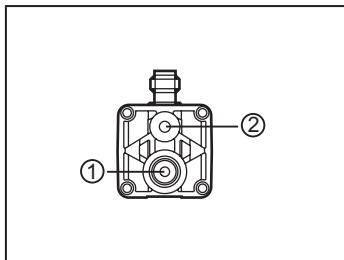

5.3 DIN rail mounting

DIN rail TH 35-7.5 to EN 60715

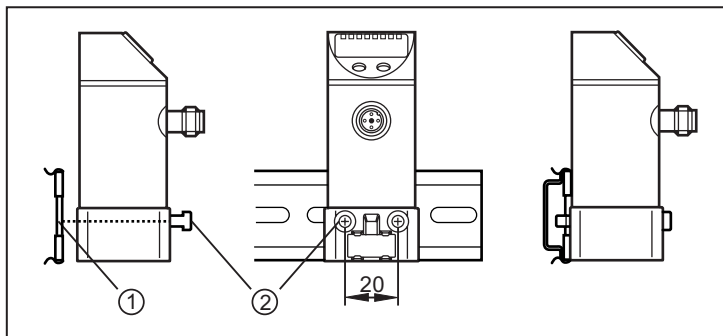

- ▶ Fix the mounting clip (1) with the screws M4 x 40 (2) to the flange. Maximum tightening torque: 2.5 Nm.
- ▶ Hook the unit into the DIN rail and clip it into place.

Removal:

- ▶ Lever out the mounting clip with a screwdriver at the top or at the bottom and remove the unit.

5.4 Rear panel mounting

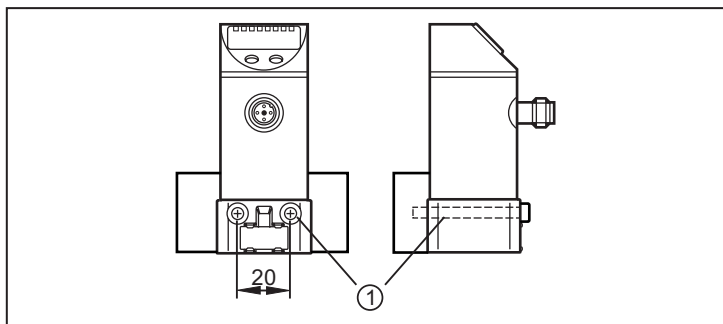

- ▶ Fix the unit with 2 screws M4 x 40 (1) (not included) to the rear panel. Maximum tightening torque: 2.5 Nm.

5.5 Mounting on a pressure-carrying rear panel

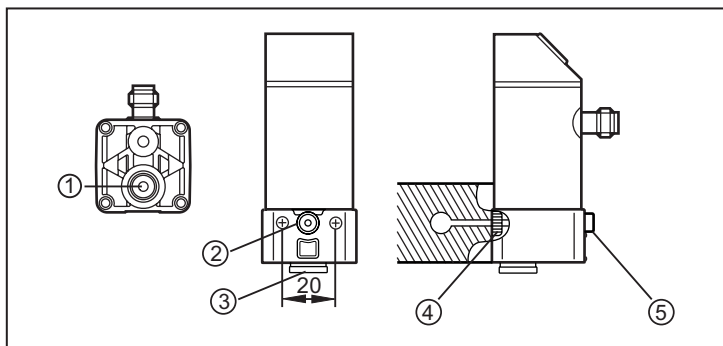

1: main pressure connection

2: gland for pressure connection 2 mm

3: adapter plug (not included)

4: O-ring (not included)

5: fixing screws (not included)

- ▶ Cover the main pressure connection with an adapter plug G $\frac{1}{8}$. Maximum tightening torque: 8 Nm.
- ▶ Remove the gland for pressure connection.
- ▶ Insert the O-ring 3 x 2 and connect the connection to the medium-carrying channel (diameter 2 mm).
- ▶ Fix the unit with 2 screws M4 x 40 to the rear panel. Maximum tightening torque: 2.5 Nm.

5.6 Floor mounting

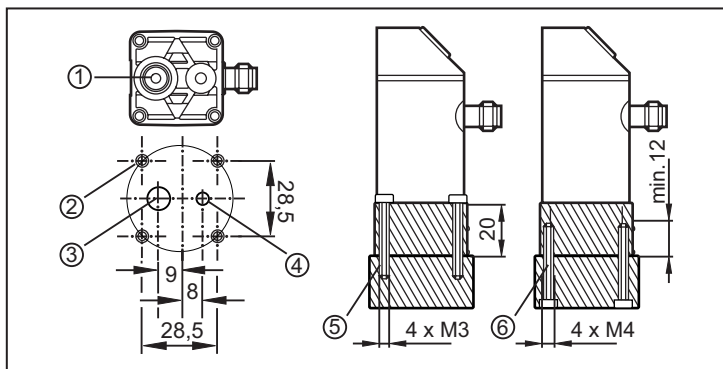

- 1: main pressure connection
2: fixing holes (4 threaded holes M3 or 4 bore holes with 4.5 mm diameter for fixing screws M4)
3: bore hole for G $\frac{1}{8}$ adapter
4: bore hole for ventilation connection
5: fixing screws M3 (not included)
6: fixing screws M4 (not included)

- ▶ Arrange for bore holes for fixing screws and pressure connections in the floor plate.
- ▶ Screw the pressure connection or adapter G $\frac{1}{8}$ to the main pressure connection (1) and tighten. Maximum tightening torque: 8 Nm.
- ▶ For mounting in a pressure-carrying floor plate: insert an O-ring for sealing (not included).
- ▶ Place the unit on the floor plate. Screw 4 screws M3 from the top through the flange into the floor plate. Maximum tightening torque: 1.5 Nm.

As an alternative:

- ▶ Place the unit on the floor plate. Screw 4 screws M4 from below through the floor plate into the flange. Maximum tightening torque: 2.5 Nm.



The ventilation connection must not be obstructed by mounting or soiling.

5.7 Mounting on a maintenance unit

The unit can be integrated in maintenance units by means of an adapter $R\frac{1}{8}$ to $R\frac{1}{8}$ (order no. E37350) or by means of the T pipe mounting set (order no. E37360). When using the indicated accessories the pressure sensor can be aligned.

Mounting with adapter

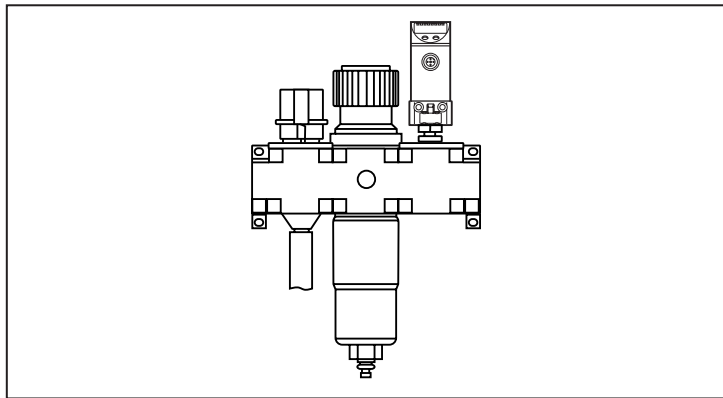

Mounting with T pipe mounting set

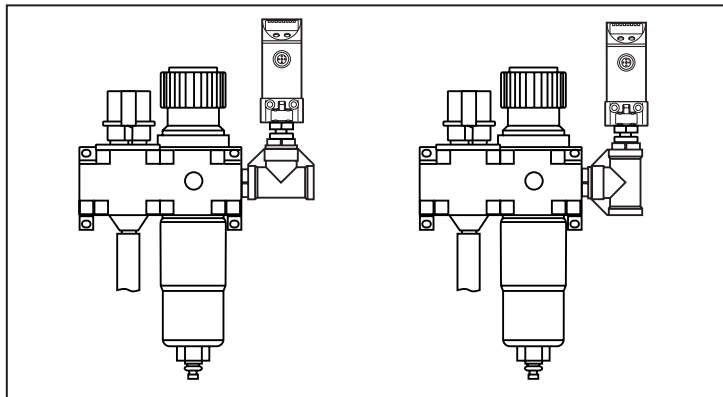

6 Electrical connection



The unit must be connected by a qualified electrician.

The national and international regulations for the installation of electrical equipment must be adhered to.

Voltage supply to SELV, PELV.

- ▶ Disconnect power.
- ▶ Connect the unit as follows:

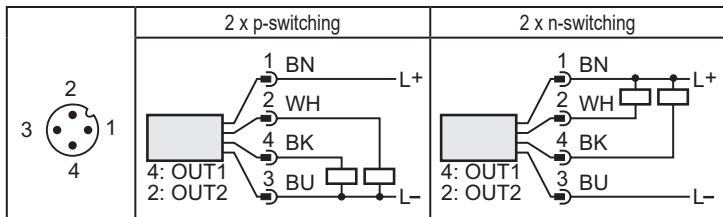

UK

Pin 1	Ub+
Pin 3	Ub-
Pin 4 (OUT1)	• binary switching output pressure monitoring
Pin 2 (OUT2)	• binary switching output if [OU2] = [Hno], [Hnc], [Fno] or [Fnc] • diagnostic output if [OU2] = [dESI]

Core colours of ifm sockets:

1 = BN (brown), 2 = WH (white), 3 = BU (blue), 4 = BK (black)

7 Operating and display elements

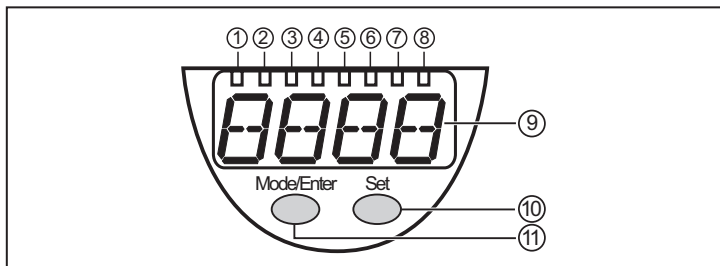

1 to 8: Indicator LEDs

- LED 1 to LED 3 = system pressure in the unit of measurement which is indicated on the label.
- LEDs 4 to 6: not used,
- LED 7, LED 8 = switching state of the corresponding output.

9: Alphanumeric display, 4 digits

- Indication of the current system pressure.
- Indication of the parameters and parameter values.

10: Set button

- Setting of the parameter values (scrolling by holding pressed; incrementally by pressing once).

11: Mode/Enter button

- Selection of the parameters and acknowledgement of the parameter values

8 Menu

8.1 Menu structure

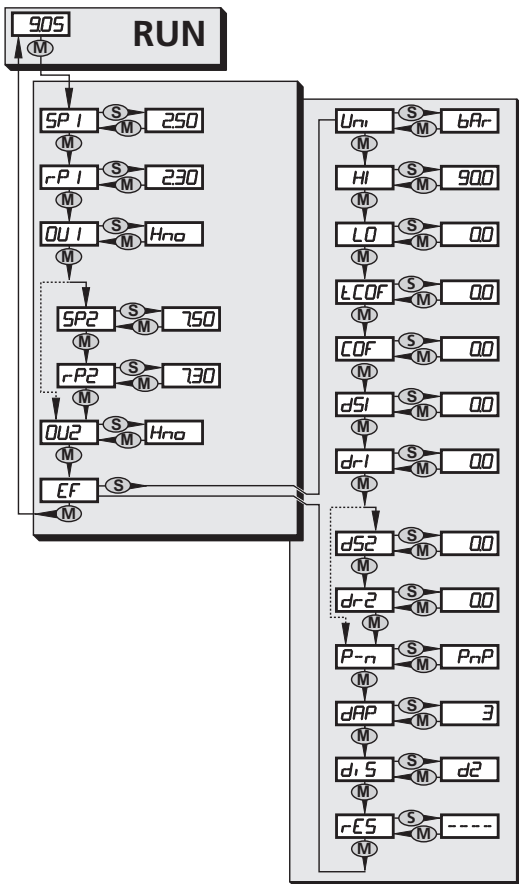

UK

8.2 Explanation of the menu



SP1/rP1	Upper / lower limit value for system pressure at which OUT1 switches.
SP2/rP2	Upper / lower limit value for system pressure at which OUT2 switches.
OU1	Output function for OUT1: <ul style="list-style-type: none">• Switching signal for the pressure limit values: hysteresis function [H ..] or window function [F ..], either normally open [. no] or normally closed [. nc].
OU2	Output function for OUT2: <ul style="list-style-type: none">• Switching signal for the pressure limit values: hysteresis function [H ..] or window function [F ..], either normally open [. no] or normally closed [. nc].• Diagnostic signal [OU2] = dESI.
EF	Extended functions / opening of menu level 2.
Uni	Standard unit of measurement for system pressure.
HI	Maximum value memory for system pressure.
LO	Minimum value memory for system pressure.
tCOF	Teach zero-point calibration.
COF	Manually enter the zero point calibration.
dS1/dS2	Switch-on delay for OUT1 / OUT2.
dr1/dr2	Switch-off delay for OUT1 / OUT2.
P-n	Output logic: pnp / npn.
dAP	Damping for the switching outputs.
diS	Update rate and orientation of the display.
rES	Restore factory settings.

9 Parameter setting

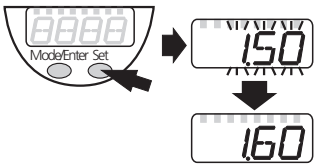

During parameter setting the unit remains in the operating mode. It continues its monitoring function with the existing parameters until the parameter setting has been completed.

9.1 General parameter setting

3 steps must be taken for each parameter setting:

1	Parameter selection ▶ Press [Mode/Enter] until the requested parameter is displayed.	
2	Setting of the parameter value ▶ Press [Set] and keep it pressed. > Current setting value of the parameter flashes for 5 s. > After 5 s: setting value is changed: incrementally by pressing the button once or continuously by keeping the button pressed.	
Numerical values are incremented continuously. To reduce the value: let the display move to the maximum setting value. Then the cycle starts again at the minimum setting value.		
3	Acknowledgement of the parameter value ▶ Press [Mode/Enter] briefly. > The parameter is displayed again. The new setting value is stored.	
Setting of other parameters: ▶ Start again with step 1.		
Finishing the parameter setting: ▶ Press [Mode/Enter] several times until the current measured value is displayed or wait for 15 s. > The unit returns to the operating mode.		

- Change from menu level 1 to menu level 2:

<p>▶ Press [Mode/Enter] until [EF] is displayed.</p> <p>If the submenu is protected with an access code, "Cod1" flashes in the display.</p> <p>▶ Press [Set] and keep it pressed until the valid code no. is displayed.</p> <p>▶ Press [Mode/Enter] briefly.</p> <p>On delivery by ifm electronic: no access restriction.</p>	
<p>▶ Press [Set] briefly.</p> <p>> The first parameter of the sub-menu is displayed (here: [Un]).</p>	

- Locking / unlocking

The unit can be locked electronically to prevent unintentional settings.

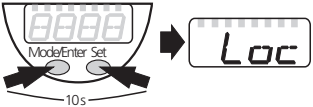
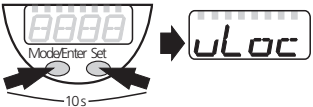
<p>▶ Make sure that the unit is in the normal operating mode.</p> <p>▶ Press [Mode/Enter] + [Set] for 10 s.</p> <p>> [Loc] is displayed.</p>	
<p>During operation: [Loc] is briefly displayed if you try to change parameter values.</p>	
<p>For unlocking:</p> <p>▶ Press [Mode/Enter] + [Set] for 10 s.</p> <p>> [uLoc] is displayed.</p>	

On delivery: unlocked.

- Timeout:

If no button is pressed for 15 s during parameter setting, the unit returns to the operating mode with unchanged values.

9.2 Setting of the output signals

9.2.1 Setting of the unit of measurement for system pressure

▶ Select [Uni] and set the unit of measurement: [bAr], [mbar], [MPa], [kPa], [PSI].	<i>Uni</i>
----------------------------------------------------------------------------------------	------------

9.2.2 Setting of the output function

▶ Select [OU1] and set the function: - [Hno] = hysteresis function / normally open - [Hnc] = hysteresis function / normally closed, - [Fno] = window function / normally open, - [Fnc] = window function / normally closed.	<i>OU 1</i>
▶ Select [OU2] and set the function: - [Hno] = hysteresis function / normally open, - [Hnc] = hysteresis function / normally closed, - [Fno] = window function / normally open, - [Fnc] = window function / normally closed, - [dES1] = output 2 is used as a diagnostic output.	<i>OU2</i>

UK

9.2.3 Setting of the switching limits

▶ Select [SP1] / [SP2] and set the value at which the output switches.	<i>SP 1</i> <i>SP2</i>
▶ Select [rP1] / [rP2] and set the value at which the output switches off. rPx is always smaller than SPx. The unit only accepts values which are lower than the value for SPx.	<i>rP 1</i> <i>rP2</i>

9.3 User settings (optional)

9.3.1 Setting of a time delay for the switching signals

[dS1] / [dS2] = switch-on delay for OUT1 / OUT2. [dr1] / [dr2] = switch-off delay for OUT1 / OUT2. ▶ Select [dS1], [dS2], [dr1] or [dr2] and set a value between 0.1 and 50 s (at 0.0 the delay time is not active).	<i>dS 1</i> <i>dS2</i> <i>dr 1</i> <i>dr2</i>
-------------------------------------------------------------------------------------------------------------------------------------------------------------------------------------------------------------------------------	--------------------------------------------------------

9.3.2 Setting of the output logic for the switching outputs

- Select [P-n] and set [PnP] or [nPn].

P-n

9.3.3 Setting of the damping for the switching outputs

- Select [dAP] and set a value.

dAP value = response time between pressure change and change of the switching status in milliseconds.

The following fix values can be set; they define the switching frequency (f) of the output:

dAP	3	6	10	17	30	60	125	250	500
f [Hz]	170	80	50	30	16	8	4	2	1

dAP

9.3.4 Configuration of the display

- Select [diS] and set the update rate and orientation of the display:

- [d1]: update of the measured values every 50 ms.
- [d2]: update of the measured values every 200 ms.
- [d3]: update of the measured values every 600 ms.
- [rd1], [rd2], [rd3]: display as for d1, d2, d3; rotated by 180°.
- [OFF]: the display is switched off in the operating mode.

d, S

9.3.5 Zero point calibration

Setting of an offset value for accuracy optimisation for differential pressure measurement.

- ▶ Select [COF] and set a value between -10 % and 10 % of the measuring span. The internal measured value "0" is shifted by this value.
- ▶ The following setting values improve the accuracy by 6 mbar per 1 bar system pressure:

For system pressure [bar]	Setting value for PN7809 / PY7809 in %	Setting value for PN7834 in %
1	-0.2	---
2	-0.6	---
3	-0.9	-0.1
4	-1.2	-0.1
5	-1.6	-0.2
6	-2.0	-0.2
7	-2.4	-0.2
8	-2.7	-0.3
9	-3.0	-0.3
10	-3.4	-0.4

As an alternative: automatic adjustment of the offset in the range 0 bar \pm 10 % of the measuring span.

- ▶ Make sure that the differential pressure is 0 bar or as close as possible to the 0 bar mark.
- ▶ Press [Mode/Enter] until [tCOF] appears.
- ▶ Press [Set] and keep it pressed.
 - > The current offset value (in %) briefly flashes.
- ▶ Release [SET].
- ▶ Press [Mode/Enter] briefly (= to confirm the new offset value).

Reset of the teached value:

- ▶ Select [COF] and set the value [0].

COF

UK

tCOF

9.4 Service functions

9.4.1 Reading of the min/max values for system pressure

<ul style="list-style-type: none">▶ Select [HI] or [LO], briefly press [Set]. [HI] = maximum value, [LO] = minimum value. Delete memory: <ul style="list-style-type: none">▶ Select [HI] or [LO].▶ Press [Set] and keep it pressed until [----] is displayed.▶ Press [Mode/Enter] briefly.	
----------------------------------------------------------------------------------------------------------------------------------------------------------------------------------------------------------------------------------------------------------------------------------------------------------------------------------------------	-----------------------------------------------------------------------------------

9.4.2 Reset of all parameters to factory setting

<ul style="list-style-type: none">▶ Select [rES].▶ Press [Set] and keep it pressed until [----] is displayed.▶ Press [Mode/Enter] briefly. We recommend taking down your own settings in the table before carrying out a reset (→ 13 Factory setting).	
----------------------------------------------------------------------------------------------------------------------------------------------------------------------------------------------------------------------------------------------------------------------------------------	-----------------------------------------------------------------------------------

10 Operation

After power on, the unit is in the Run mode (= normal operating mode). It carries out its measurement and evaluation functions and provides output signals according to the set parameters.

Operating indications → chapter 7 Operating and display elements.

10.1 Reading of the set parameters

- ▶ Press [Mode/Enter] until the requested parameter is displayed.
- ▶ Press [Set] briefly.
- > The unit displays the corresponding parameter value for about 15 s. After another 15 s the unit returns to the Run mode.

10.2 Fault indication

[OL]	Overload pressure (measuring range exceeded)
[UL]	Underload pressure (below measuring range)
[SC1]	Short circuit in OUT1*
[SC2]	Short circuit in OUT2*
[SC]	Short circuit in both outputs*
[Err]	Flashing: internal fault

*The output concerned is switched off as long as the short circuit exists.
The messages SC1, SC2, SC, and Err are shown even if the display is switched off.

10.3 Setting ranges

		SP1 / SP2		rP1 / rP2		ΔP
		min	max	min	max	
PN7834	bar	-0.90	10.00	-0.95	9.95	0.05
	PSI	-13	145	-14	144	1
	MPa	-0.090	1.000	-0.095	0.995	0.005
PN7809 PY7809	mbar	-975	1000	-980	995	5
	PSI	-14.1	14.5	-14.2	14.4	0.1
	kPa	-97.5	100.0	-98.0	99.5	0.5

ΔP = step increment

UK

11 Factory setting

	Factory setting	User setting
SP1	25% VMR *	
rP1	23% VMR *	
OU1	Hno	
OU2	Hno	
SP2	75% VMR *	
rP2	73% VMR *	
COF	0.0	
dS1	0.0	
dr1	0.0	
dS2	0.0	
dr2	0.0	
P-n	PnP	
dAP	6	
diS	d2	
Uni	bAr	

* = the indicated percentage of the final value of the measuring range (VMR) of the corresponding sensor in bar is set

More information at www.ifm.com