

CE

Operating instructions
Flow meter compressed air
SD6020

UK

80282583 / 01 03 / 2023

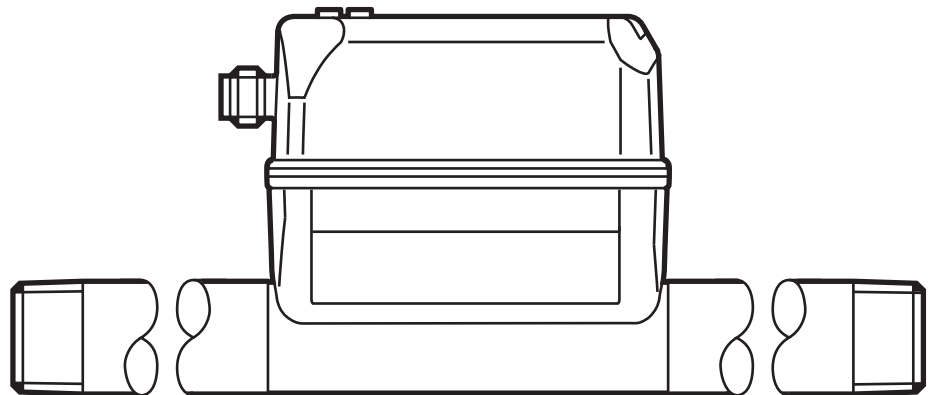

Contents

1	Preliminary note.....	4
1.1	Symbols used	4
1.2	Warnings used.....	4
2	Safety instructions	5
3	Functions and features	6
3.1	Pressure Equipment Directive (PED)	6
4	Function.....	7
4.1	Processing of the measured signals.....	7
4.2	Switching output	8
4.3	Analogue output.....	9
4.4	Consumed quantity monitoring [ImP]	11
4.4.1	Meter reading	11
4.4.2	Counter reset	11
4.4.3	Consumed quantity monitoring via pulse signals	12
4.4.4	Consumed quantity monitoring via preset counter	12
4.5	Measured value damping	13
4.6	Low flow cut-off	13
4.7	Simulation.....	13
4.8	Colour of the characters in the display	14
4.9	IO-Link.....	15
4.9.1	Additional functions via IO-Link	15
5	Installation.....	15
5.1	Installation location	16
5.2	Installation position	16
5.2.1	Inlet and outlet pipe lengths.....	16
5.2.2	Orientation	17
5.3	Installation in pipes	17
6	Electrical connection.....	18
7	Operating and display elements	20
8	Menu.....	21
8.1	Process value display (RUN).....	21
8.2	Main menu.....	22
8.3	Extended functions (EF).....	23

8.4 Submenu OUT1.....	24
8.5 Submenu OUT2.....	26
8.6 Submenu CFG.....	28
8.7 Submenus MEM, DIS	30
8.8 Submenus COLR, SIM	32
9 Set-up.....	34
10 Parameter setting	34
10.1 Parameter setting in general	35
10.1.1 Select submenu.....	35
10.1.2 Change to the process value display (RUN mode)	35
10.1.3 Lock / unlock.....	35
10.1.4 Timeout.....	36
10.2 Settings for volumetric flow monitoring.....	36
10.2.1 Limit monitoring OUT1 or OUT2 / hysteresis function	36
10.2.2 Limit monitoring OUT1 or OUT2 / window function	36
10.2.3 Analogue signal volumetric flow OUT2.....	36
10.3 Settings for consumed quantity monitoring	37
10.3.1 Quantity monitoring by pulse signal OUT1 or OUT2	37
10.3.2 Quantity monitoring by preset counter OUT1 or OUT2	37
10.3.3 Manual counter reset.....	37
10.3.4 Time-controlled counter reset.....	37
10.3.5 Deactivation of the counter reset.....	37
10.3.6 Counter reset using an external signal	38
10.4 Settings for temperature monitoring	38
10.4.1 Limit monitoring OUT1 or OUT2 / hysteresis function	38
10.4.2 Limit monitoring OUT1 or OUT2 / window function	38
10.4.3 Analogue signal temperature OUT2	38
10.5 User settings (optional).....	39
10.5.1 Standard display.....	39
10.5.2 Standard unit of measurement for volumetric flow	39
10.5.3 Standard unit of measurement for temperature.....	39
10.5.4 Measured value damping	39
10.5.5 Output logic	40
10.5.6 Low flow cut-off.....	40
10.5.7 Standard conditions.....	40
10.5.8 System pressure.....	40

10.5.9	Colour of the characters in the display	41
10.5.10	Switch-on /switch-off delay	41
10.5.11	Error behaviour of the outputs	42
10.5.12	Restore factory setting.....	42
10.6	Diagnostic functions	43
10.6.1	Read min/max values	43
10.6.2	Simulation.....	43
11	Operation	44
12	Error correction.....	44
13	Maintenance, repair and disposal.....	46
14	Factory setting	47

1 Preliminary note



Detailed instructions, technical data, approvals and other information via the QR code on the unit / on the packaging or at www.ifm.com.

1.1 Symbols used

- ▶ Instructions
- > Reaction, result
- [...] Designation of keys, buttons or indications
- Cross-reference



Important note
Non-compliance may result in malfunction or interference.



Information
Supplementary note.

1.2 Warnings used



CAUTION!

Warning of personal injury.
Slight reversible injuries may result.

2 Safety instructions

- The device described is a subcomponent for integration into a system.
 - The manufacturer is responsible for the safety of the system.
 - The system manufacturer undertakes to perform a risk assessment and to create a documentation in accordance with legal and normative requirements to be provided to the operator and user of the system. This documentation must contain all necessary information and safety instructions for the operator, the user and, if applicable, for any service personnel authorised by the manufacturer of the system.
- Read this document before setting up the product and keep it during the entire service life.
- The product must be suitable for the corresponding applications and environmental conditions without any restrictions.
- Only use the product for its intended purpose (→ Functions and features).
- Only use the product for permissible media (→ Technical data).
- If the operating instructions or the technical data are not adhered to, personal injury and/or damage to property may occur.
- The manufacturer assumes no liability or warranty for any consequences caused by tampering with the product or incorrect use by the operator.
- Installation, electrical connection, set-up, operation and maintenance of the unit must be carried out by qualified personnel authorised by the machine operator.
- Protect units and cables against damage.

3 Functions and features

The unit monitors the standard volume flow of compressed air in industrial use.

It detects the 4 process variables flow velocity, volumetric flow quantity, consumed quantity and medium temperature.

All indications apply to standard volume flow to DIN ISO 2533, i.e. volume flow at 1013 mbar, 15 °C and 0 % relative air humidity. The unit can be set to different standard conditions (→ 10.5.7).



This is a class A product. This product may cause radio interference in domestic areas.

► If required, take appropriate EMC screening measures.

3.1 Pressure Equipment Directive (PED)

The units comply with the Pressure Equipment Directive. They are designed for stable gases of group 2 fluids and manufactured in accordance with sound engineering practice.

4 Function

- The volumetric flow is monitored by a calorimetric measuring system, the measured signals are evaluated by the electronics.
- The unit detects the media temperature of the volumetric flow as additional process value.
- The unit features an IO-Link interface
- The unit displays the current process values.
- The unit has many self-diagnostic options.
- A simulation mode allows simplified set-up of the sensor.

UK

4.1 Processing of the measured signals

The unit generates 2 output signals according to the parameter setting:

OUT1: 6 selection options

- switching signal for volumetric flow quantity limit
- switching signal for temperature limit
- switching signal for preset counter
- pulse signal for quantity meter
- IO-Link
- OFF (output switched to high impedance)

OUT2: 8 selection options

- switching signal for volumetric flow quantity limit
- switching signal for temperature limit
- switching signal for preset counter
- switching signal for quantity meter
- analogue signal for volumetric flow quantity
- analogue signal for temperature
- input for external counter reset signal (InD)
- OFF (output switched to high impedance)

4.2 Switching output

OUTx changes its switching status if it is above or below the set switching limits (flow or temperature). Hysteresis or window function can be selected.

Example of volumetric flow monitoring:

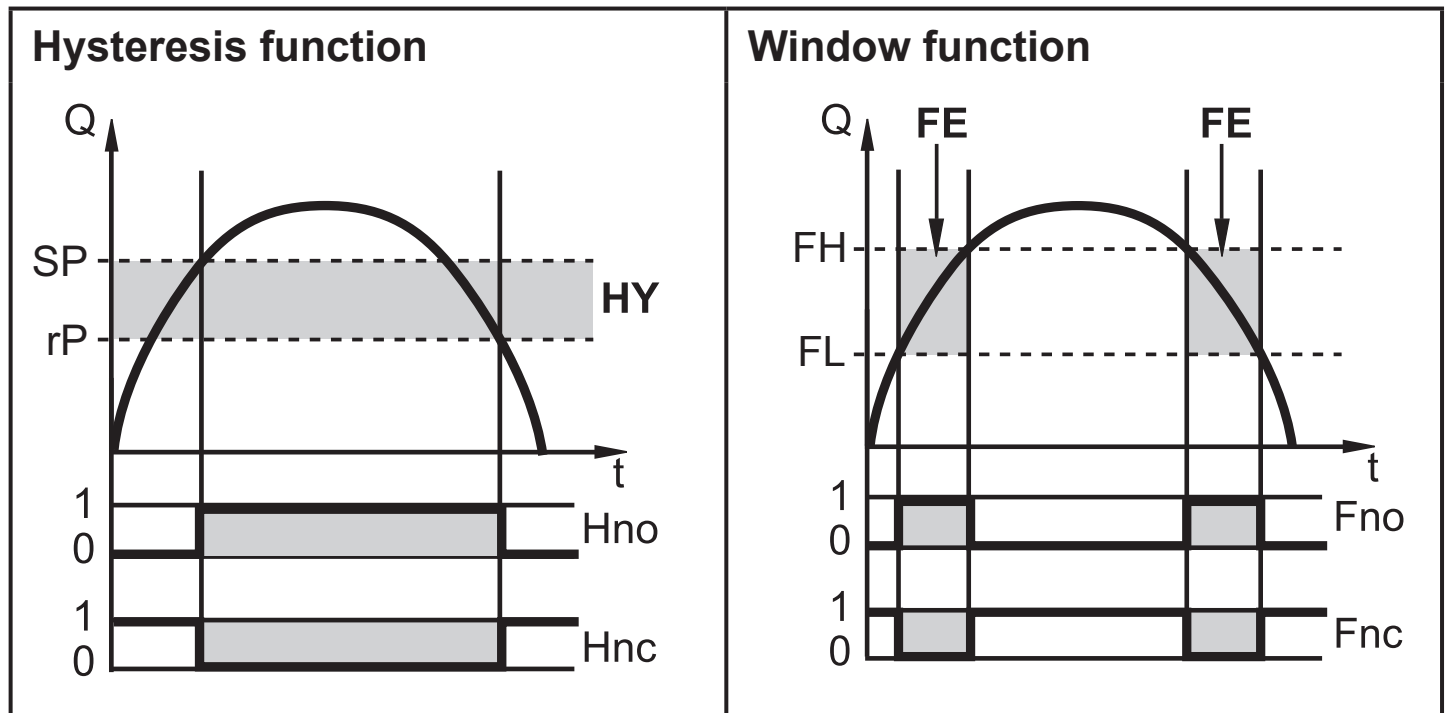

SP = set point

rP = reset point

HY = hysteresis

Hno / Fno = NO (normally open)

FH = upper limit

FL = lower limit

FE = window

Hnc / Fnc = NC (normally closed)



When the hysteresis function is set, the set point (SP) is defined first and then the reset point (rP) which must have a lower value. If only the set point is changed, the reset point is changed automatically; the difference remains constant.



When set to the window function, the upper limit value (FH) and the lower limit value (FL) have a fixed hysteresis of 0.25 % of the final value of the measuring range. This keeps the switching status of the output stable if the volumetric flow varies slightly.

4.3 Analogue output

The unit provides an analogue signal that is proportional to the volumetric flow quantity or the medium temperature.

Within the measuring range the analogue signal is 4...20 mA.

The measuring range is scalable:

- [ASP2] determines at which measured value the output signal is 4 mA.
- [AEP2] determines at which measured value the output signal is 20 mA.



Minimum distance between [ASP2] and [AEP2] = 20 % of the final value of the measuring range.

UK

If the measured value is outside the measuring range or in the event of an internal error, the current signal indicated in Fig. 1 is provided.

For measured values outside the display range or in case of a fault, messages are displayed (cr.UL, UL, OL, cr.OL, Err; → 12).

The analogue signal in case of a fault is adjustable (→ 10.5.11):

- [FOU] = On determines that the analogue signal goes to the upper final value (21.5 mA) in case of an error.
- [FOU] = OFF determines that the analogue signal goes to the lower final value (3.5 mA) in case of an error.
- [FOU] = OU defines that in case of a fault the analogue signal reacts as defined by the current parameters.

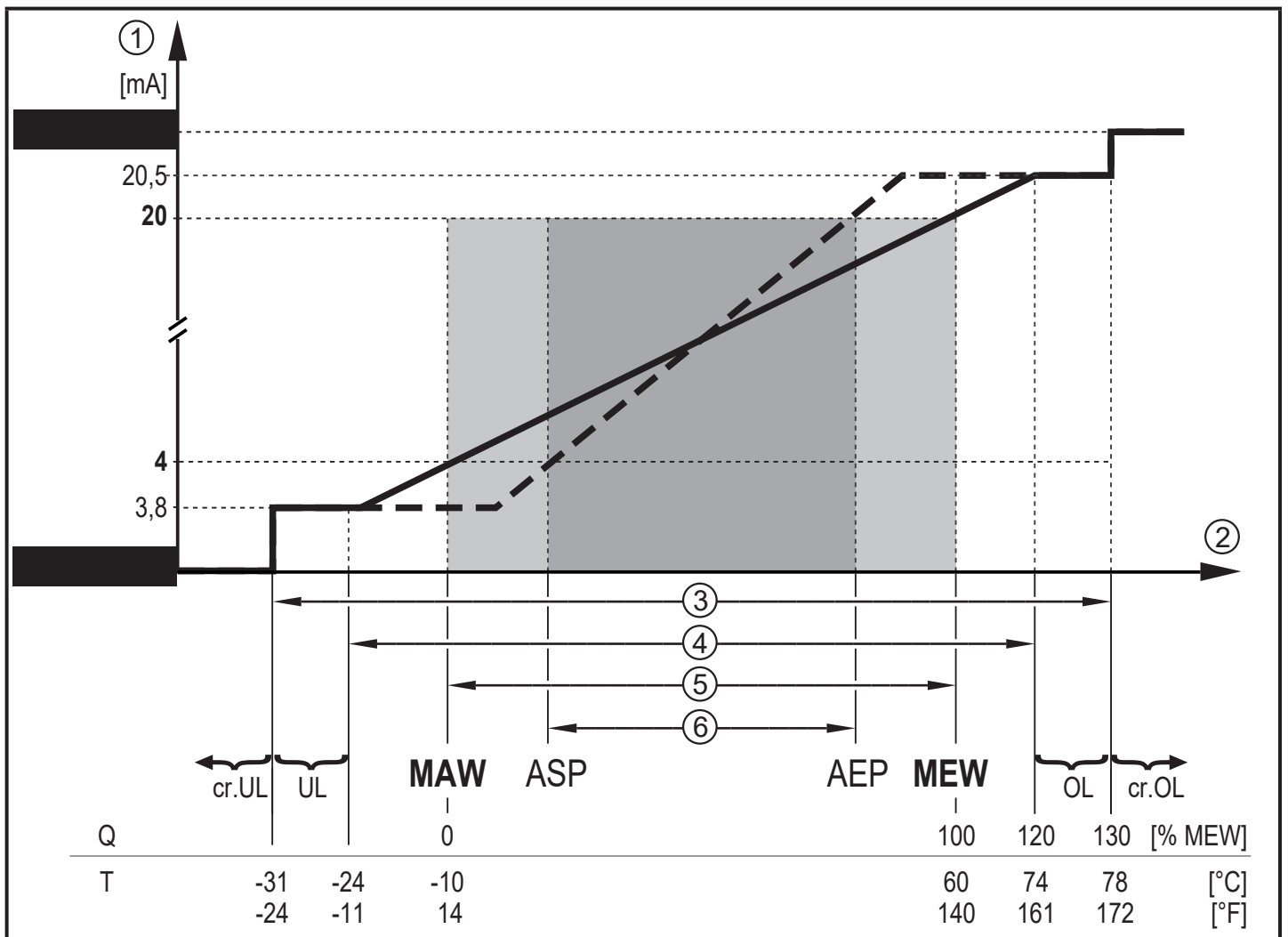

Fig. 1: Characteristics of the analogue output according to the standard IEC 60947-5-7.

- ① analogue signal
- ② measured value (volumetric flow or temperature)
- ③ detection zone
- ④ display range
- ⑤ measuring range
- ⑥ scaled measuring range

Q: flow

T: temperature

MAW: initial value of the measuring range for non-scaled measuring range (With setting of a low-flow cut for Q: signal output starting at MAW + LFC → 4.6.)

MEW: final value of the measuring range for non-scaled measuring range

ASP: analogue start point with scaled measuring range

AEP: analogue end point with scaled measuring range

UL: below the display range

OL: above the display range

cr.UL: below the detection zone (error)

cr.OL: above the detection zone (error)

4.4 Consumed quantity monitoring [ImP]

The unit has an internal quantity meter (totaliser). It continuously sums up the consumed quantity and provides this process value both on the display and via the IO-Link interface.

Pulse signals or a switching signal (preset counter) can be used to monitor the consumed quantity.

→ 4.4.3 Consumed quantity monitoring via pulse signals

→ 4.4.4 Consumed quantity monitoring via preset counter

4.4.1 Meter reading

The current quantity meter count can be indicated (→ 8.1).

In addition, the value before the last reset is saved. This value and the time since the last reset can also be displayed (→ 8.1).



The meter saves the totalled volumetric flow quantity every 10 minutes. After a power failure this value is available as the current meter reading. If a time-controlled reset is set, the elapsed time of the set reset interval is also saved. So the possible data loss can be at most 10 minutes.

4.4.2 Counter reset

There are different ways to reset the quantity meter.

→ 10.3.3 Manual counter reset

→ 10.3.4 Time-controlled counter reset

→ 10.3.6 Counter reset using an external signal

→ Counter reset via the IO-Link interface

If the quantity meter is not reset by applying one of the above-mentioned methods, an automatic reset takes place when the maximum volumetric flow quantity that can be displayed is exceeded (overflow).



OUT1 and OUT2 cannot be used simultaneously for the consumed quantity monitoring.



The accuracy of the consumed quantity measurement depends on the accuracy of the flow measurement.

4.4.3 Consumed quantity monitoring via pulse signals

Every time the flow rate set with [ImPS] has been reached (pulse value), the output provides a pulse signal.



OUT1 and OUT2 cannot be used simultaneously for the pulse output.

4.4.4 Consumed quantity monitoring via preset counter

When the flow rate set under [ImPS] has been reached, the output provides a switching signal.

The setting of the parameter [rTo] defines if the volumetric flow quantity has to be reached irrespective of the time (1) or within a set time (2) so that the output switches:

	[rTo]	Output	Counter reset
(1)	OFF (→ 10.3.5)	<ul style="list-style-type: none"> The output switches when the volumetric flow quantity set with [ImPS] has been reached. The output remains switched until the counter reset. 	<ul style="list-style-type: none"> The preset counter is only reset <ul style="list-style-type: none"> - when a manual reset is made (→ 10.3.3) or - when the maximum display range has been exceeded (overflow).
(2)	1, 2,... h 1, 2,... d 1, 2,... w (→ 10.3.4)	<ul style="list-style-type: none"> The output switches only when the volumetric flow quantity set with [ImPS] is reached within the set time. The output remains switched until the counter reset. 	<ul style="list-style-type: none"> If the output is not switched, the preset counter is automatically reset when the time has elapsed and the count starts again (→ 10.3.4 Time-controlled counter reset) If the output is switched, the preset counter is only reset. <ul style="list-style-type: none"> - when a manual reset is made (→ 10.3.3) or - when the maximum display range has been exceeded (overflow).

4.5 Measured value damping

The damping time [dAP.F] allows to set after how many seconds the output signal has reached 63 % of the final value if the flow value changes suddenly. The set damping time stabilises the switching outputs, the display and the process value transfer via the IO-Link interface.

The damping time is added to the response time of the sensor (→ Technical data).

The signals [UL] and [OL] (→ 12) are defined under consideration of the damping time.

4.6 Low flow cut-off

With the function low flow cut-off [LFC] it is possible to suppress small volumetric flow quantities. Flows below the LFC value are evaluated by the sensor as standstill ($Q = 0$).

4.7 Simulation

With this function, the process values flow, temperature and meter reading of the totaliser are simulated and their signal chain is reviewed.

When the parameters cr.UL, UL, OL und cr.OL are set, the process values that lead to an error message or warning can be simulated (→ 12).

When the simulation is started, the values of the totaliser are frozen and the simulated totaliser is set to 0. The simulated flow value then has an effect on the simulated totaliser. When the simulation is ended, the initial totaliser values are restored.



The simulation does not have any effect on the currently existing process values. The outputs operate as previously set.



During the simulation the original totaliser value remains saved without any changes even if there is a real flow.



During the simulation operation, no error message of the currently real application is available. They are suppressed by the simulation.

4.8 Colour of the characters in the display

The colour of the characters in the display can be set via the parameter [coL.x]:

- Permanent definition of the display colour:
 - bk/wh (black/white)
 - yellow
 - green
 - red
- Colour change from red to green or vice versa (Fig. 2):
 - r-cF (red display colour between the limits cFL...cFH)
 - G-cF (green display colour between the limits cFL...cFH)

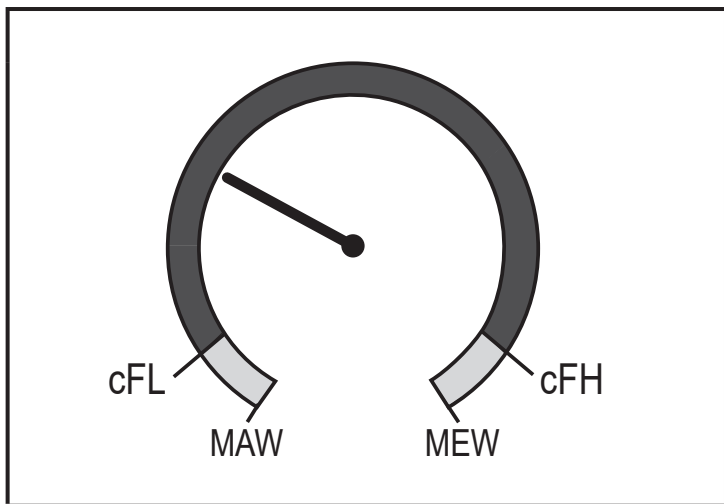

cFL = lower limit
cFH = upper limit

MAW = initial value of the measuring range
MEW = final value of the measuring range

Fig. 2: Colour setting window function



The limits can be freely selected within the measuring range and are independent of the output function set for OUT1 and OUT2.

4.9 IO-Link

This unit has an IO-Link communication interface which enables direct access to process and diagnostic data. In addition it is possible to set the parameters of the unit while it is in operation. Operation of the unit via an IO-Link interface requires an IO-Link master.

With a PC, suitable IO-Link software and an IO-Link adapter cable communication is possible when the system is not in operation.

The IO-DDs necessary for the configuration of the unit, detailed information about process data structure, diagnostic information, parameter addresses and the necessary information about the required IO-Link hardware and software can be found at www.ifm.com.

UK

4.9.1 Additional functions via IO-Link

The following functions are only available via the IO-Link interface by means of a parameter setting software:

Flash on / Flash off	Standard command for localising the sensor in the system. When activated: > switching status indicating LEDs are flashing > display: "IO-Link" (green, flashes)
-------------------------	--

5 Installation



CAUTION!

If the medium temperature is above 50 °C (122 °F), parts of the housing can increase in temperature to over 65 °C (149 °F).

- > Risk of burns.
- ▶ Protect the housing against contact with flammable substances and unintentional contact.
- ▶ Apply the supplied warning label to the sensor cable.



- ▶ Ensure that the system is free of pressure during installation.
- ▶ The rules and regulations for the installation and operation of compressed air equipment must be observed.

5.1 Installation location



- ▶ Install the unit downstream of the cold dryer.
- ▶ Install the unit near the load.
- ▶ The unit can be installed downstream of a maintenance unit.
- ▶ If oil is used for the loads: install the unit upstream of the oiler.

5.2 Installation position

5.2.1 Inlet and outlet pipe lengths

Structures in the pipe, bends, valves, reducing pieces and the like affect the function of the unit.

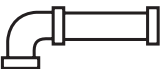
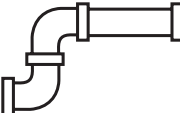
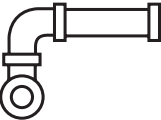
- ▶ Adhere to the distances between sensor and interference:

Interference		Distance to the sensor
	changes to the pipe diameter	10 x pipe diameter
	90° elbow	10 x pipe diameter
	two 90° elbows, one plane	15 x pipe diameter
	two 90° elbows, two planes	25 x pipe diameter
	valve, slide	40 x pipe diameter



Shut-off valves and control devices are not allowed directly in front of the unit.

- ▶ Avoid diameter changes between the inlet pipe length and the unit.

If a diameter change cannot be prevented, make sure that the diameter of the inlet pipe length is greater than the diameter at the unit.

5.2.2 Orientation

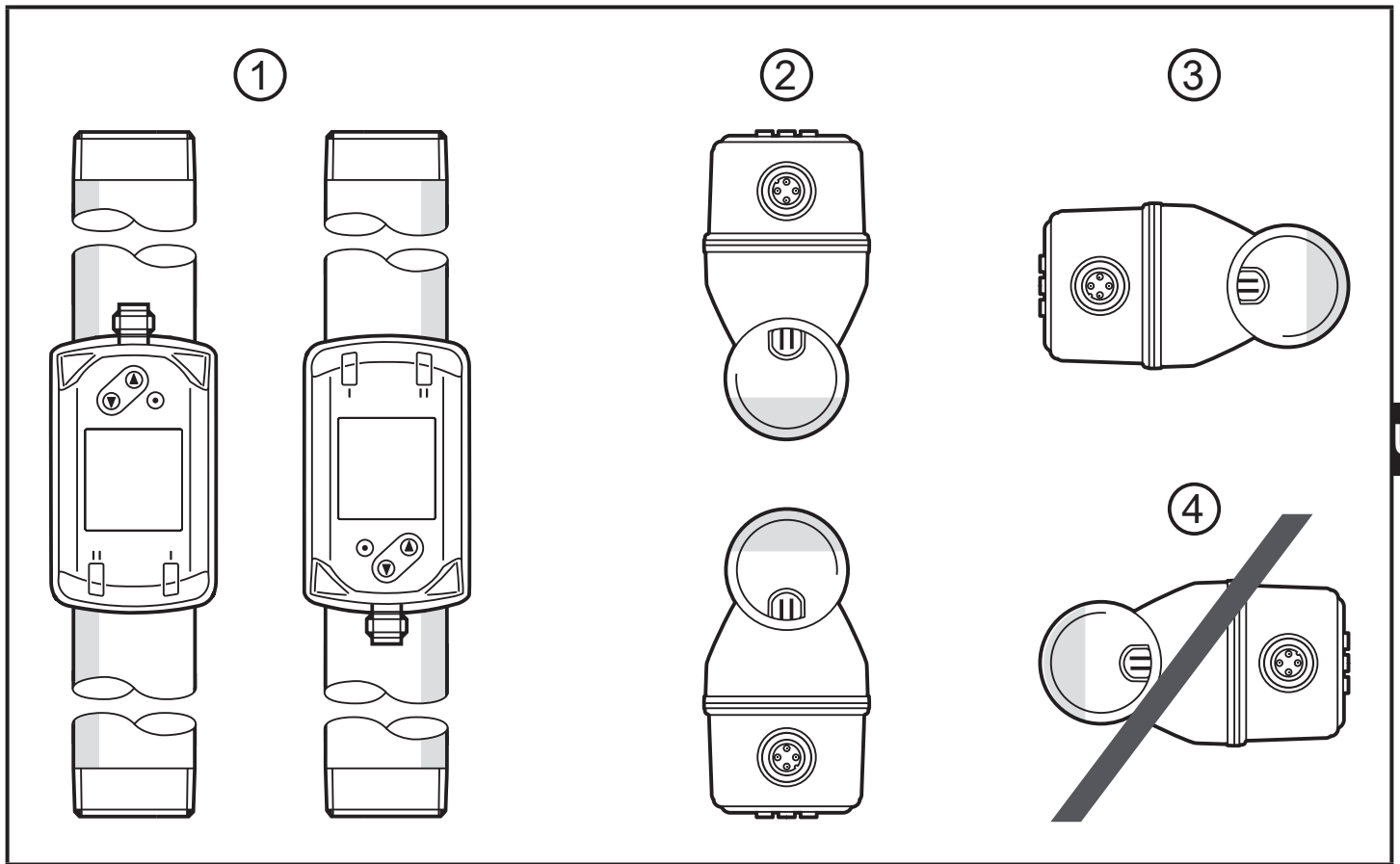
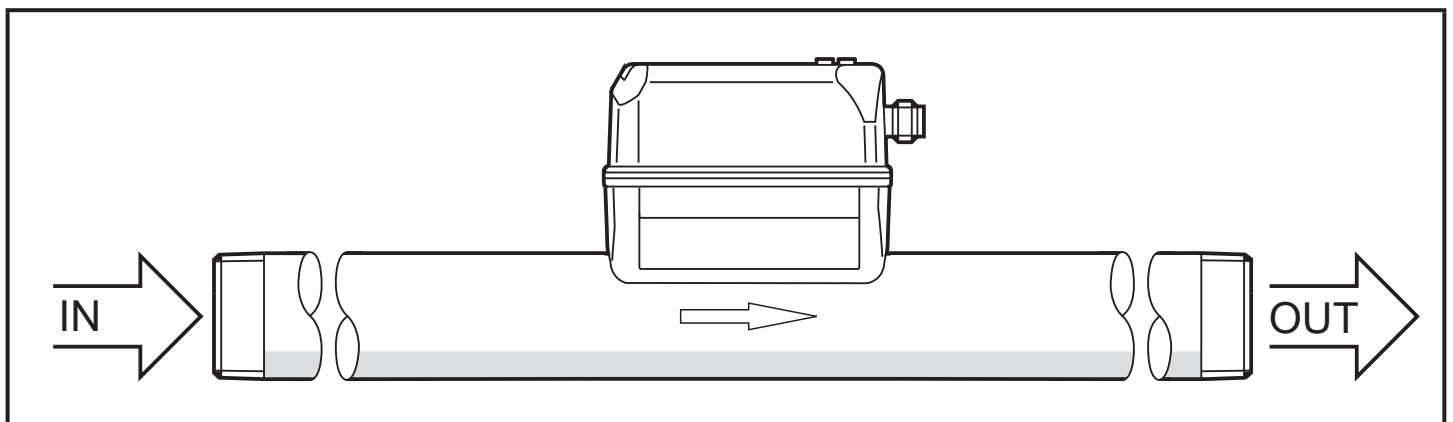

Fig. 1: Orientation of the pipe length and the unit

- 1: pipe length vertical, unit any
- 2: pipe length horizontal, unit vertical
- 3: pipe length right, unit on side
- 4: avoid: pipe length left, unit on side

5.3 Installation in pipes

- Fit the unit in the pipe in accordance with the flow direction (arrow on the unit):



- Tighten both adapters in opposite direction by applying the defined tightening torque. Tightening torque: 100 Nm

6 Electrical connection



The device must be connected by a qualified electrician. Voltage supply according to EN 50178, SELV, PELV.

- ▶ Disconnect power.
- ▶ Connect the unit as follows:

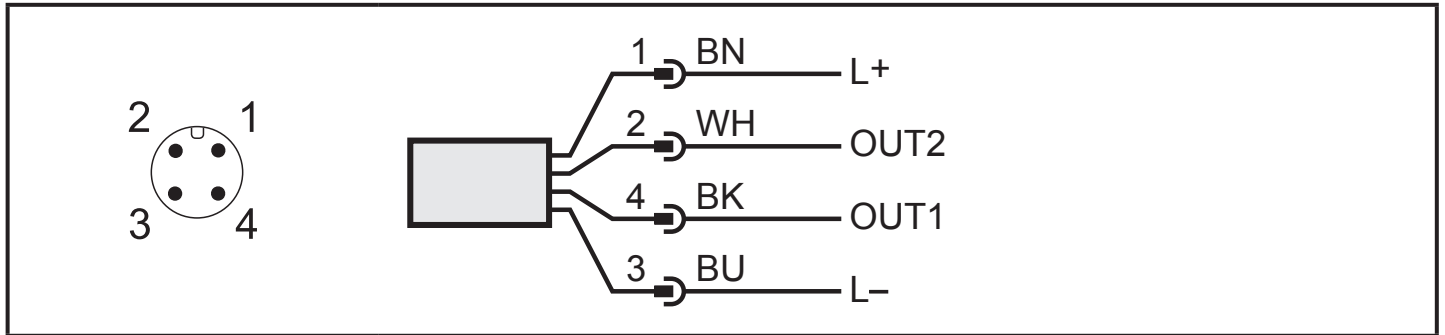

Colours to DIN EN 60947-5-2

BK: black; BN: brown; BU: blue; WH: white

Pin	Connection
4 (OUT1)	<ul style="list-style-type: none"> • switching signal for volumetric flow • switching signal for temperature • switching signal for preset counter • pulse signal for quantity meter • IO-Link • OFF
2 (OUT2/InD)	<ul style="list-style-type: none"> • switching signal for volumetric flow • switching signal for temperature • switching signal for preset counter • pulse signal for quantity meter • analogue signal for volumetric flow • analogue signal for temperature • input for external counter reset signal (InD) • OFF

Circuit examples:

2 x positive switching

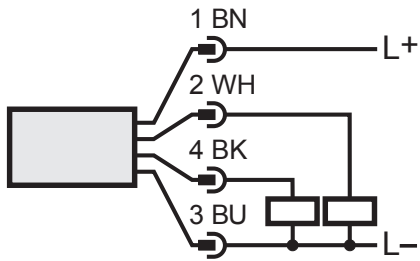

2 x negative switching

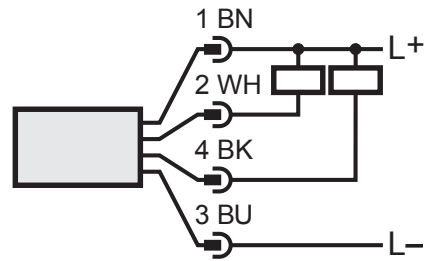

1 x positive switching / 1 x analogue

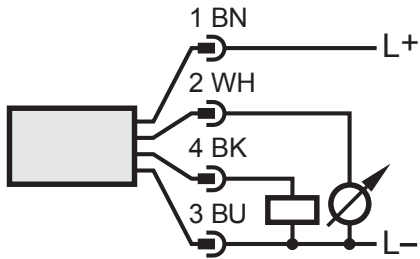

1 x negative switching / 1 x analogue

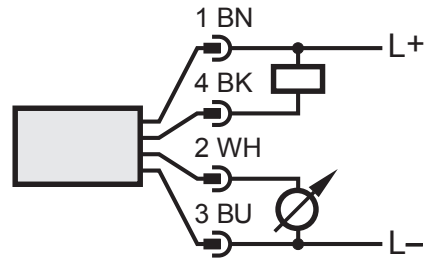

UK

7 Operating and display elements

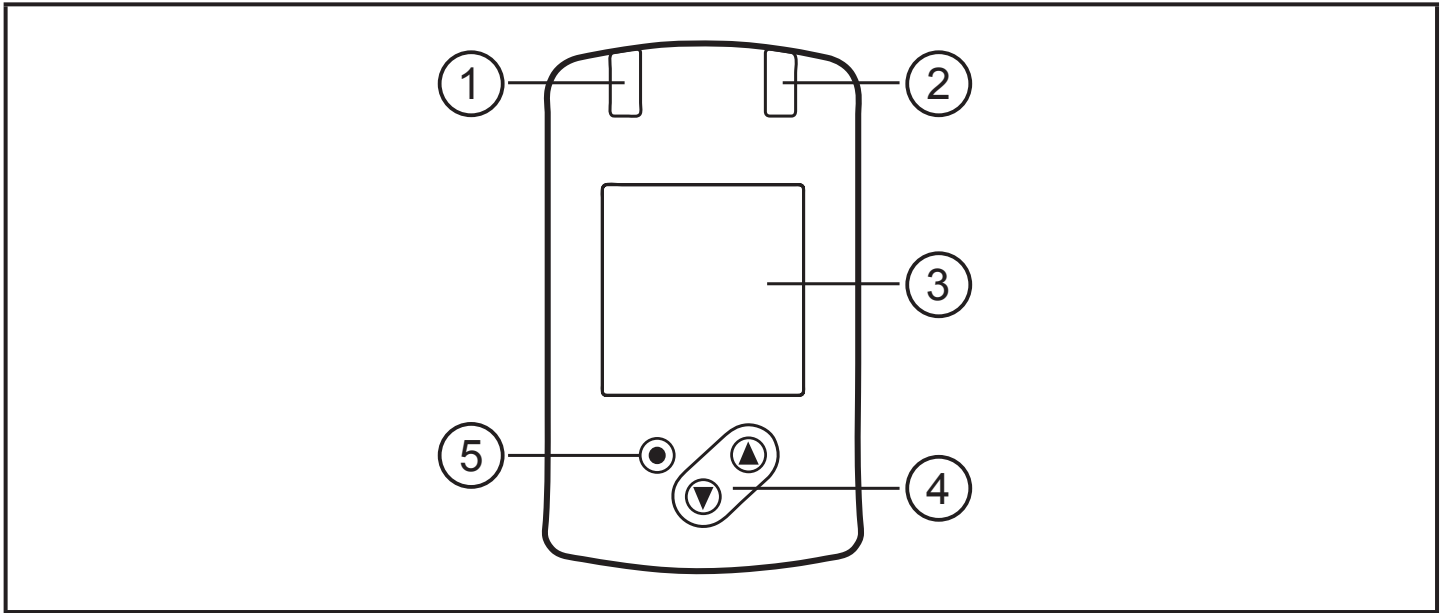

1 and 2: Switching status LEDs

- LED 1 = switching status OUT1 (on if output 1 is switched)
- LED 2 = switching status OUT2 (on if output 2 is switched)

3: TFT display

- Display of the current process values (volumetric flow quantity, temperature, totaliser)
- Display of the parameters and parameter values

4: [▲] and [▼] buttons

- Select parameter
- Change parameter value (hold button pressed)
- Change of the display unit in the normal operating mode (RUN mode)
- Lock / Unlock (buttons pressed simultaneously > 10 seconds)

5: [●] = Enter button

- Change from the RUN mode to the main menu
- Change to the setting mode
- Acknowledge the set parameter value



Display illumination:

- unit temperature > 70°C: brightness automatically reduced.
- unit temperature ≥ 100°C: display automatically switched off.

8 Menu

8.1 Process value display (RUN)

It is possible to select three process value indications during operation:

- ▶ Press [▲] or [▼].
- > The display changes between the standard indication and two other views.
- > After 30 s, the device returns to the standard display.

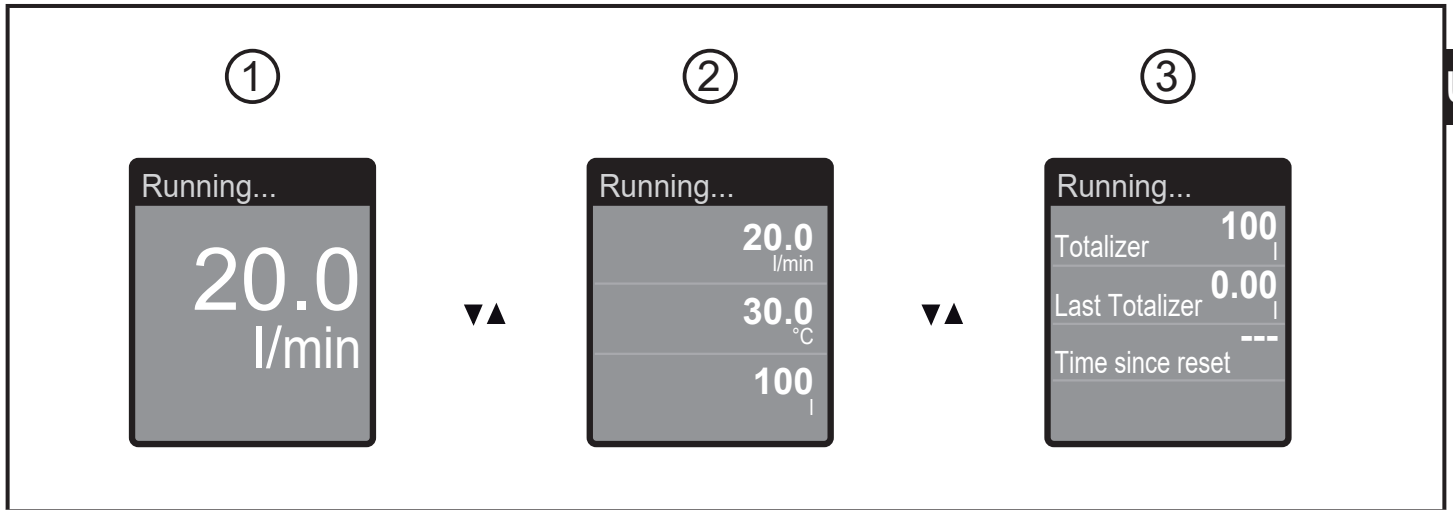

- 1: standard display as set under [diS.L] (→ 10.5.1)
- 2: overview of all process values
- 3: overview totaliser values

8.2 Main menu

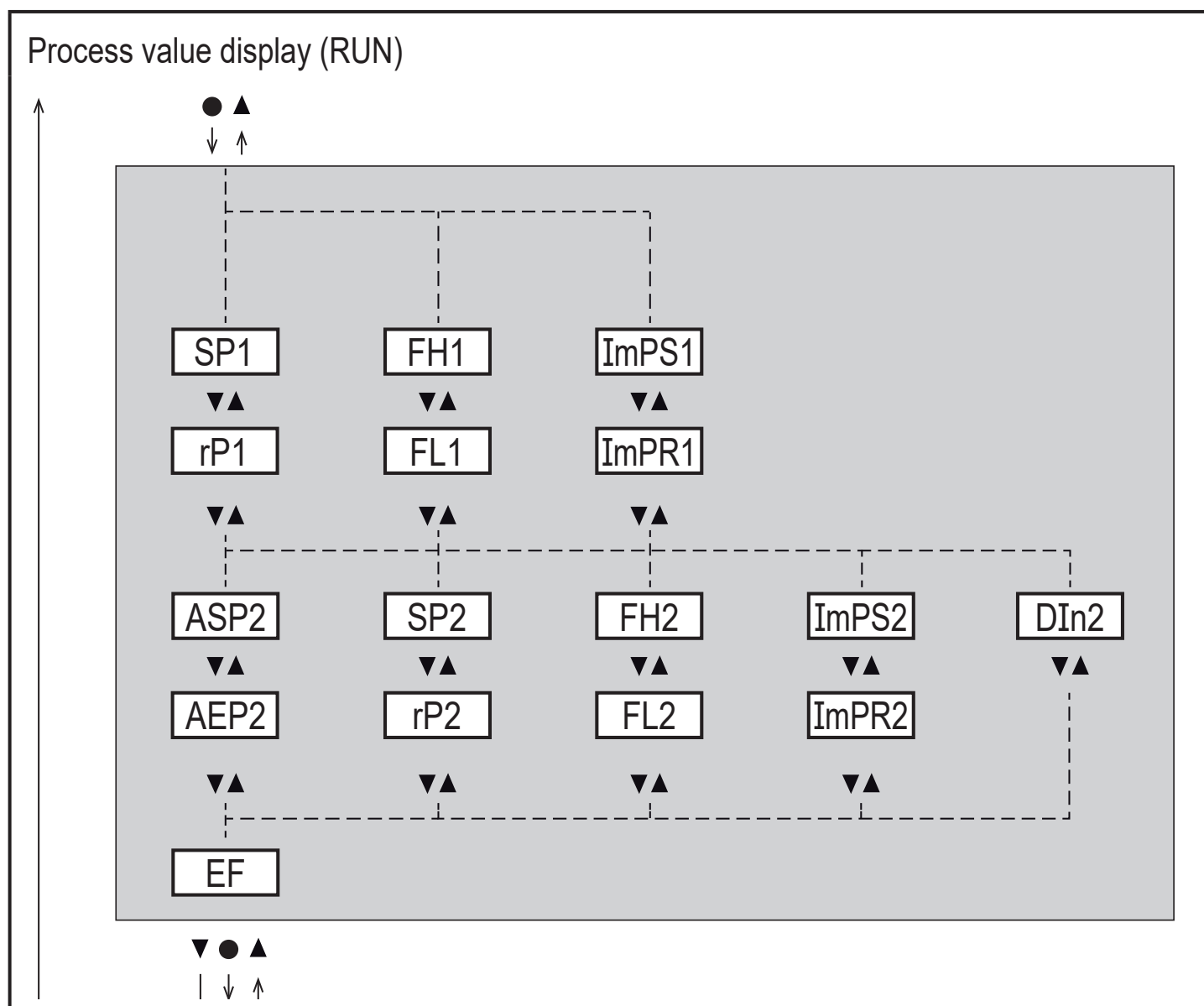

Explanation of the parameters → 8.4 Submenu OUT1 and → 8.5 Submenu OUT2



The displayed parameters change when the factory setting in submenu OUT1 and OUT2 is changed.

8.3 Extended functions (EF)

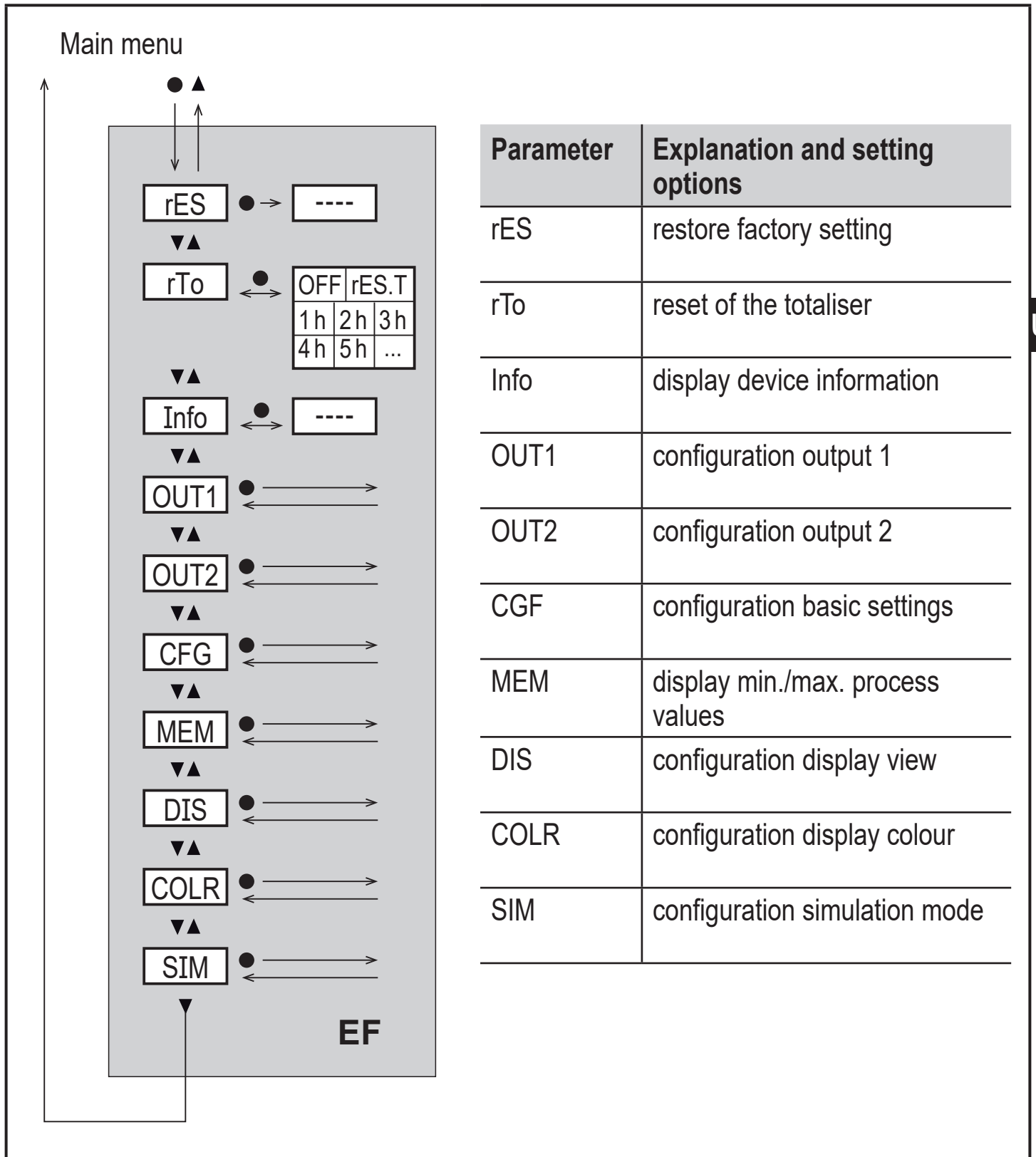

UK

8.4 Submenu OUT1

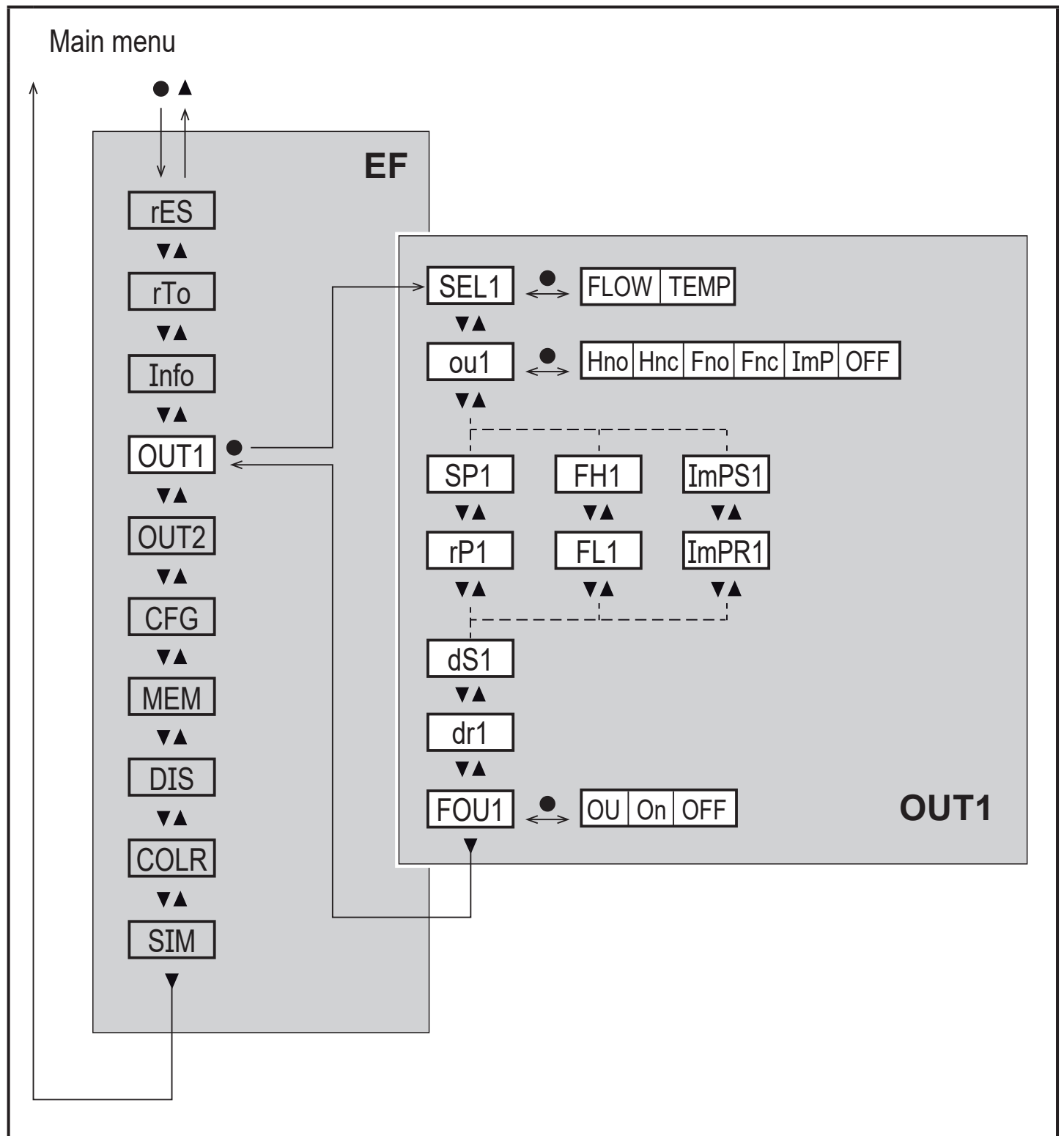

Explanations submenu OUT1

Parameter	Explanation and setting options
SEL1	standard unit of measurement for evaluation by OUT1: FLOW (volumetric flow) or TEMP (temperature)
ou1	output function for OUT1: <ul style="list-style-type: none"> • flow Hno, Hnc, Fno, Fnc, ImP • temperature: Hno, Hnc, Fno, Fnc <p>Hno = switching signal with hysteresis function normally open Hnc = switching signal with hysteresis function normally closed Fno = switching signal with window function normally open Fnc = switching signal with window function normally closed ImP = consumed quantity monitoring (totaliser function) OFF = output OFF (of high impedance)</p>
SP1	set point for OUT1
rP1	reset point for OUT1
FH1	upper limit value for OUT1
FL1	lower limit for OUT1
ImPS1	pulse value = volumetric flow quantity at which 1 pulse is delivered.
ImPR1	configuration of OUT1 for consumed quantity monitoring: YES (pulse signal), no (switching signal).
dS1	switching delay on OUT1
dr1	switch-off delay on OUT1
FOU1	response of OUT1 / OUT2 in case of an internal fault: OU = output reacts as in normal case On = output switches ON / analogue signal goes to 21.5 mA. OFF = output switches OFF / analogue signal goes to 3.5 mA.  FOU1 is not available if ou1 = ImP was selected.

UK

8.5 Submenu OUT2

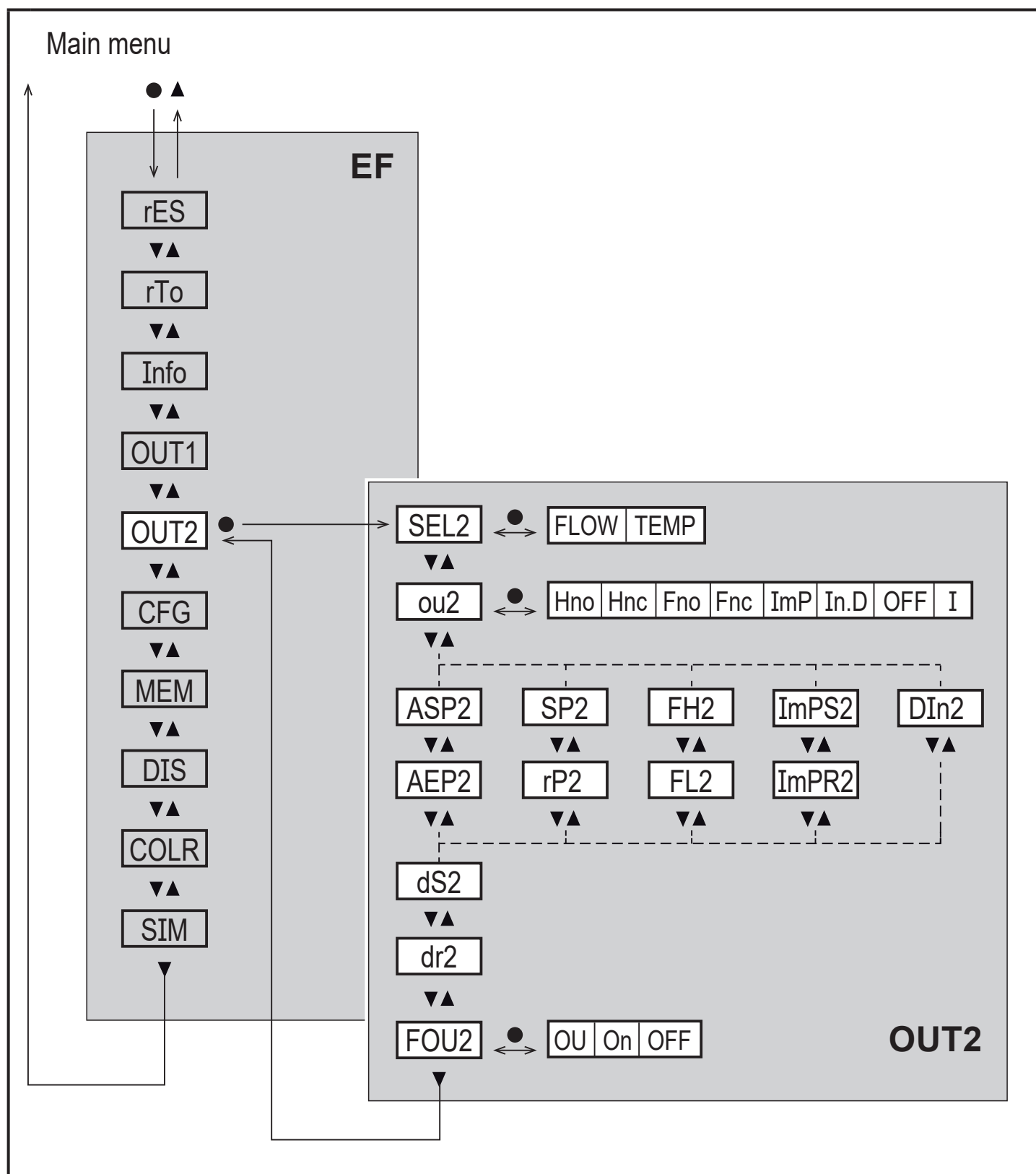

Explanation submenu OUT2

Parameter	Explanation and setting options
SEL2	standard measured variable for evaluation by OUT2: FLOW (volumetric flow) or TEMP (temperature)
ou2	output function for OUT2: <ul style="list-style-type: none"> • flow Hno, Hnc, Fno, Fnc, I, ImP • temperature: Hno, Hnc, Fno, Fnc, I <p>Hno = switching signal with hysteresis function normally open Hnc = switching signal with hysteresis function normally closed Fno = switching signal with window function normally open Fnc = switching signal with window function normally closed ImP = consumed quantity monitoring (totaliser function) I = analogue signal 4...20 mA. In.D = input for external counter reset signal OFF = output OFF (of high impedance)</p>
ASP2	analogue start point for OUT2
AEP2	analogue end point for OUT2
SP2	set point for OUT2
rP2	reset point for OUT2
FH2	upper limit value for OUT2
FL2	lower limit for OUT2
ImPS2	pulse value = volumetric flow quantity at which 1 pulse is provided.
ImPR2	configuration of OUT2 for consumed quantity monitoring: YES (pulse signal), no (switching signal).
DIn2	reset of the totaliser via external signal: +EDG, -EDG, HIGH, LOW
dS2	switching delay on OUT2
dr2	switch-off delay on OUT2
FOU2	response of OUT2 in case of an internal fault: OU = output reacts as in normal case On = output switches ON / analogue signal goes to 21.5 mA. OFF = output switches OFF / analogue signal goes to 3.5 mA.  FOU2 is not available if ou2 = ImP was selected.

8.6 Submenu CFG

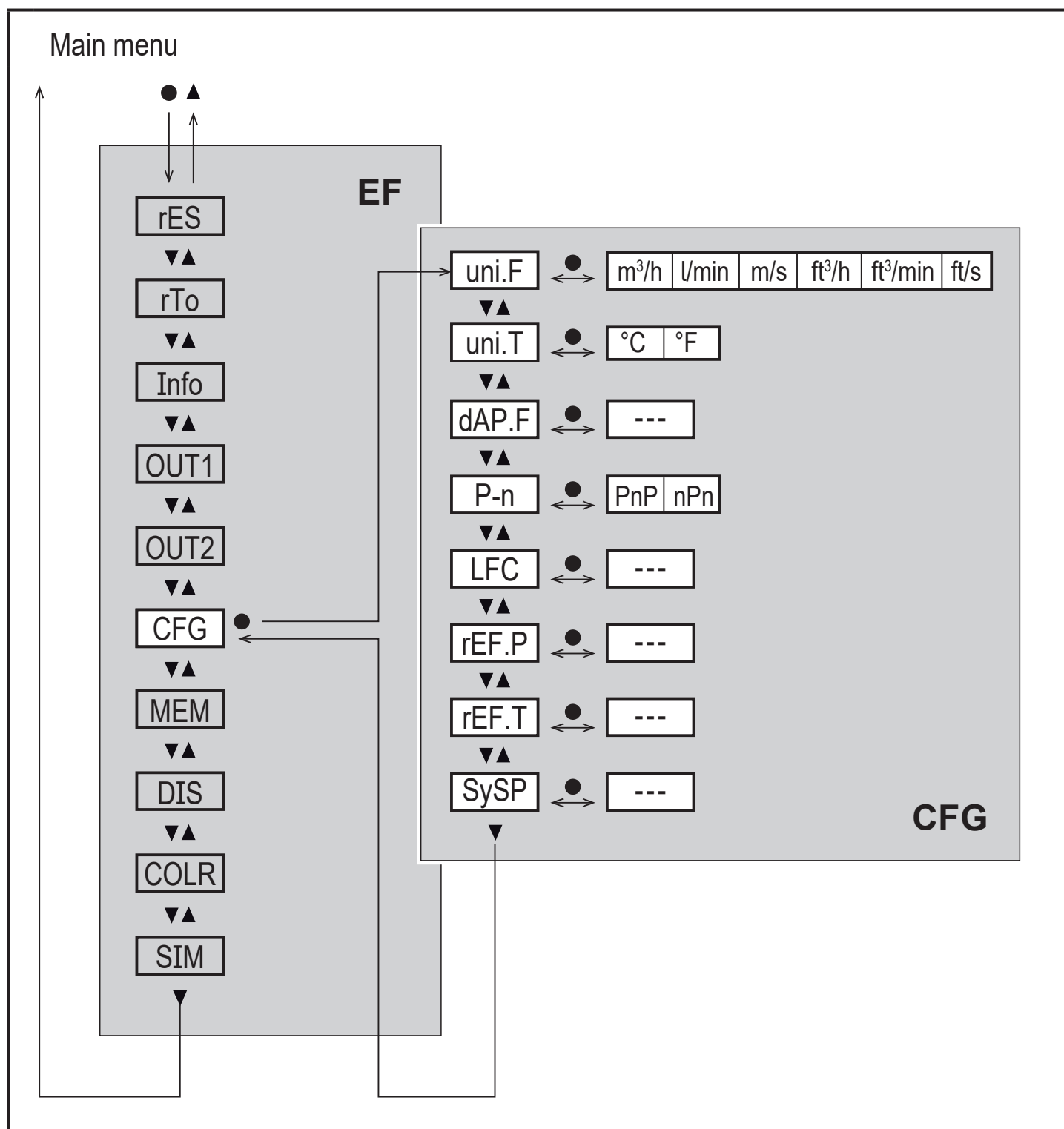

Explanation submenu CFG

Parameter	Explanation and setting options
uni.F	standard unit of measurement for volumetric flow
uni.T	standard unit of measurement for temperature
dAP.F	measured value damping for volumetric flow
P-n	output logic
LFC	low flow cut-off
rEF.P	standard pressure to which the measured and display values for volumetric flow refer
rEF.T	standard temperature to which the measured and display values for volumetric flow refer
SySP	system pressure in the plant

UK

8.7 Submenus MEM, DIS

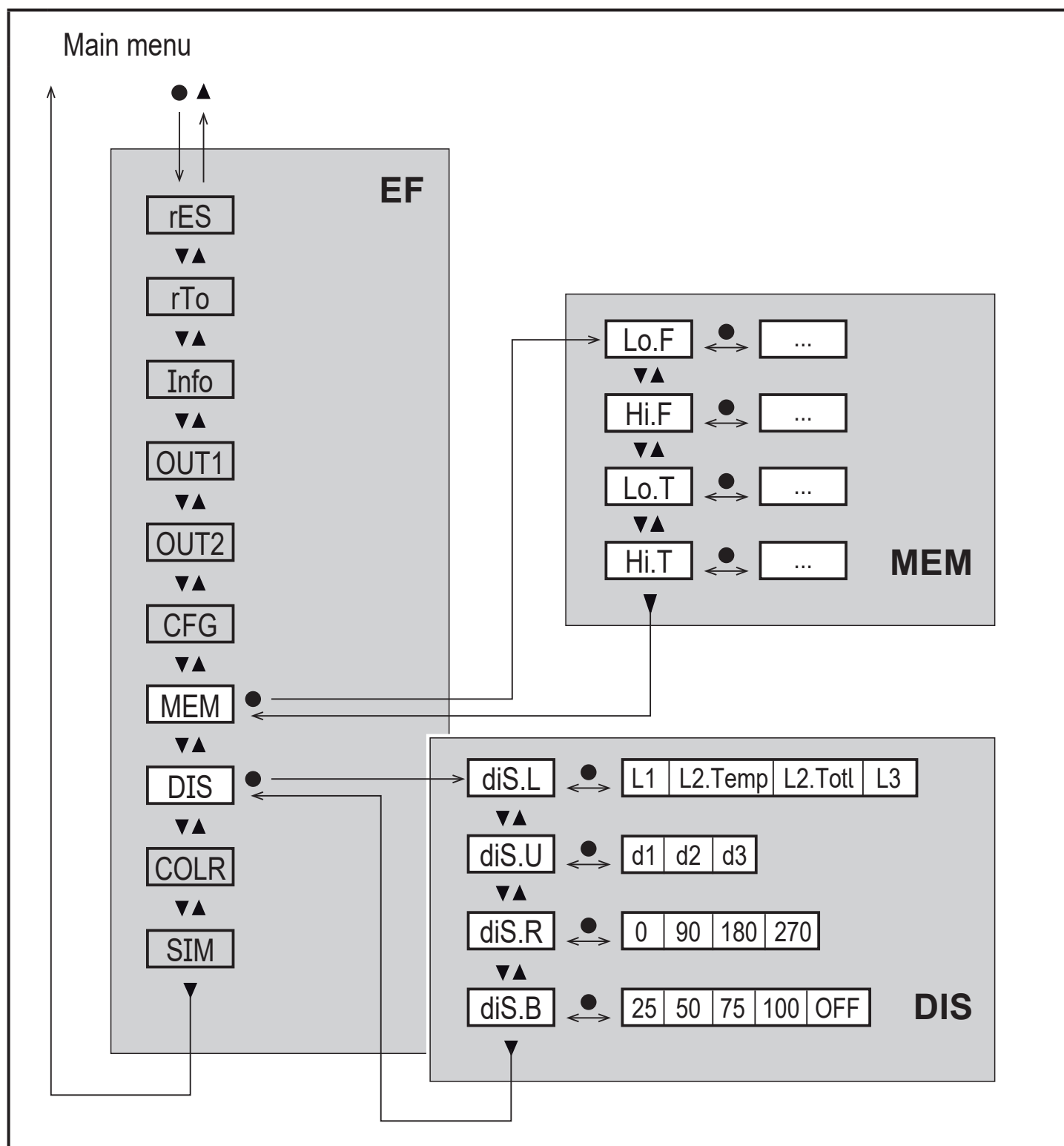

Explanation submenu MEM

Parameter	Explanation and setting options
Lo.F	min. value of the flow volume measured in the process
Hi.F	max. value of the flow volume measured in the process
Lo.T	min. value of the temperature measured in the process
Hi.T	max. value of the temperature measured in the process

Explanation submenu DIS

Parameter	Explanation and setting options
diS.L	standard process value display L1 = current process value for volumetric flow L2.Temp = current process value for flow and temperature L2.Totl = current process value for volumetric flow and totaliser L3 = current process value for volumetric flow and temperature and current totaliser value
diS.U	update rate of display d1 = high d2 = medium d3 = low
diS.R	display rotation: 0°, 90°, 180°, 270°
diS.B	display brightness: 25 %, 50 %, 75 %, 100 %, OFF (measured value display in the RUN mode switched off)

UK

8.8 Submenus COLR, SIM

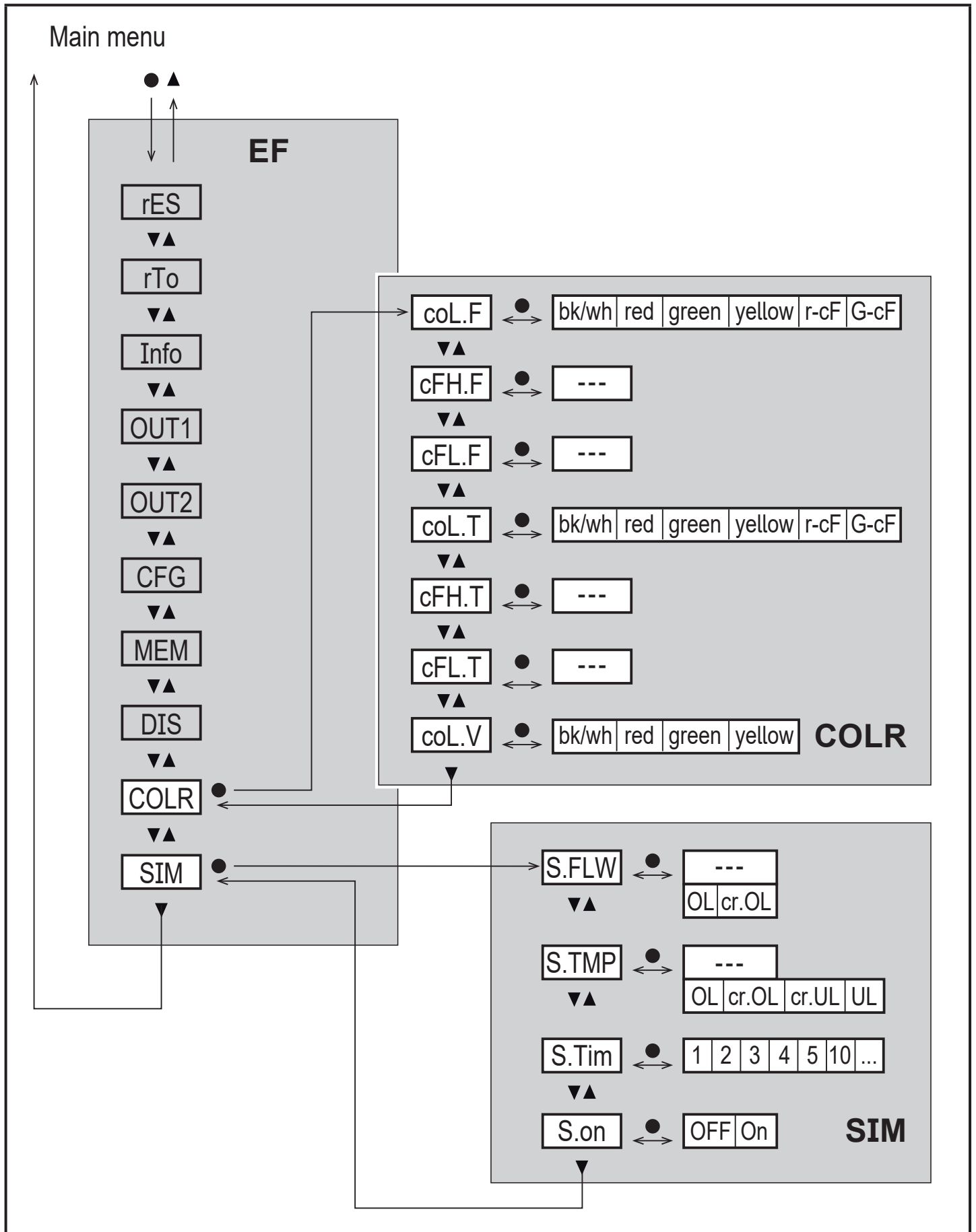

Explanation submenu COLR



The displayed parameters change when the factory setting in submenu OUT1 and OUT2 is changed.

Parameter	Explanation and setting options
coL.F	colour of the characters in the display for the flow rate value
cFH.F	upper limit of the colour change for flow rate measurement
cFL.F	lower limit of the colour change for flow rate measurement
coL.T	colour of the characters in the display for the temperature value
cFH.T	upper limit of the colour change for temperature measurement
cFL.T	lower limit of the colour change for temperature measurement
coL.V	colour of the characters in the display for the totaliser value
bk/wh	permanently black/white
yellow	permanently yellow
green	permanently green
red	permanently red
r-cF	display colour between limits cFL...cFH red, outside green.
G-cF	display colour between limits cFL...cFH green, outside red.

UK

Explanation submenu SIM

Parameter	Explanation and setting options
S.FLW	simulated flow coefficient
S.TMP	simulated temperature value
cr.UL	measured value below the detection zone → error message
UL	measured value below the display range → warning
OL	measured value above the display range → warning
cr.OL	measured value above the detection zone → error message
S.Tim	simulation time in minutes
S.On	simulation status: OFF, On

9 Set-up

After power on and expiry of the power-on delay time of approx. 1 s, the unit is in the Run mode (= normal operating mode). It carries out its measurement and evaluation functions and generates output signals according to the set parameters.

- During the power-on delay time the outputs are switched as programmed:
 - ON with normally open function (Hno / Fno)
 - OFF with normally closed function (Hnc / Fnc)
 - OFF for consumed quantity monitoring (ImP)
- If output 2 is configured as analogue output, the output signal is at 20 mA during the power-on delay time.

10 Parameter setting



CAUTION!

The housing can heat up considerably.

> Risk of burns

- ▶ Do not touch the device with your hands.
- ▶ Use another object (e.g. a ballpoint pen) to carry out settings on the unit.

Parameters can be set before installation and set-up of the unit or during operation.



If you change parameters during operation, this will influence the function of the plant.

- ▶ Ensure that there will be no malfunctions in your plant.

During parameter setting the unit remains in the operating mode. It continues to monitor with the existing parameter until the parameter setting has been completed.



The parameters can also be set via the IO-Link interface.



Functions which can only be set via the IO-Link interface: → 4.9.1.

10.1 Parameter setting in general

1. Change from the RUN mode to the main menu	[●]
2. Select the requested parameter	[▲] or [▼]
3. Change to the setting mode	[●]
4. Change the parameter value	[▲] or [▼] > 1 s
5. Acknowledge the set parameter value	[●]
6. Return to the RUN mode	> 30 seconds (timeout)

UK



If [🔒 Locked via Communication] is displayed when an attempt is made to modify a parameter value, an IO-Link communication is active (temporary locking).



If [🔒 Locked via system] is displayed, the sensor is permanently locked via software. This locking can only be removed with a parameter setting software.

10.1.1 Select submenu

1. Press [●] to change from the process value display to the main menu.
2. Press [▼] to select the menu EF and press [●].
3. Press [▼] to select the submenu and press [●].

10.1.2 Change to the process value display (RUN mode)

There are 2 possibilities:

1. Wait for 30 seconds (→ 10.1.4 Timeout).
2. Press [▲] or [▼] to go to the end of the menu and change to the next higher menu.

10.1.3 Lock / unlock

The unit can be locked electronically to prevent unintentional settings. On delivery: not locked.

Locking:

- ▶ Make sure that the unit is in the normal operating mode.
- ▶ Press [▲] and [▼] simultaneously for 10 s until [🔒 Set Menu lock] is displayed.



During operation: [🔒 Lock via key] is displayed if you try to change parameter values.

Unlocking:

- ▶ Make sure that the unit is in the normal operating mode.
- ▶ Press [▲] and [▼] simultaneously for 10 s until [Reset menu lock] is displayed.

10.1.4 Timeout

If no button is pressed for 30 s during parameter setting, the unit returns to the operating mode with unchanged values.

10.2 Settings for volumetric flow monitoring

10.2.1 Limit monitoring OUT1 or OUT2 / hysteresis function

<ul style="list-style-type: none"> ▶ Select [uni.F] and set the unit of measurement. ▶ Select [SELx] and set FLOW. ▶ Select [oux] and adjust the switching signal: <ul style="list-style-type: none"> - Hno = hysteresis function / normally open - Hnc = hysteresis function / normally closed ▶ Select [SPx] and set the value at which the output is set. ▶ Select [rPx] and set the value at which the output is reset. 	Menu OUTx: [SELx] [oux] [SPx] [rPx]
---	---

10.2.2 Limit monitoring OUT1 or OUT2 / window function

<ul style="list-style-type: none"> ▶ Select [uni.F] and set the unit of measurement. ▶ Select [SELx] and set FLOW. ▶ Select [oux] and adjust the switching signal: <ul style="list-style-type: none"> - Fno = window function / normally open - Fnc = window function / normally closed ▶ Select [FHx] and set the upper limit of the window section. ▶ Select [FLx] and set the lower limit for the window section. 	Menu OUTx: [SELx] [oux] [FHx] [FLx]
--	---

10.2.3 Analogue signal volumetric flow OUT2

<ul style="list-style-type: none"> ▶ Select [uni.F] and set the unit of measurement. ▶ Select [SEL2] and set FLOW. ▶ Select [ou2] and select analogue signal: I (4...20 mA) ▶ Select [ASP2] and set the value at which 4 mA is provided. ▶ Select [AEP2] and set the value at which 20 mA is provided. 	Menu OUT2: [SEL2] [ou2] [ASP2] [AEP2]
---	---

10.3 Settings for consumed quantity monitoring

10.3.1 Quantity monitoring by pulse signal OUT1 or OUT2

<ul style="list-style-type: none">▶ Select [uni.F] and set the unit of measurement.▶ Select [SELx] and set FLOW.▶ Select [oux] and adjust the pulse output: ImP▶ Select [ImPSx] and set pulse value (= volumetric flow quantity at which a pulse is provided):<ol style="list-style-type: none">1. Press [▲] or [▼] to select the setting range.2. Briefly press [●] to confirm the setting range.3. Press [▲] or [▼] to set the requested numeric value.4. Briefly press [●] to apply the value.▶ Select [ImPRx] and set YES.	Menu OUTx: [SELx] [oux] [ImPSx] [ImPRx]
---	---

UK

10.3.2 Quantity monitoring by preset counter OUT1 or OUT2

<ul style="list-style-type: none">▶ Select [uni.F] and set the unit of measurement.▶ Select [SELx] and set FLOW.▶ Select [oux] and adjust the pulse output: ImP▶ Select [ImPSx] and set the volumetric flow quantity at which output x switches.▶ Select [ImPRx] and set NO.	Menu OUTx: [SELx] [oux] [ImPSx] [ImPRx]
--	---

10.3.3 Manual counter reset

<ul style="list-style-type: none">▶ Select [rTo] and set rES.T.<ul style="list-style-type: none">> The totaliser is reset to zero.	Menu EF: [rTo]
---	-------------------

10.3.4 Time-controlled counter reset

<ul style="list-style-type: none">▶ Select [rTo] and set the requested value (intervals of hours, days or weeks).<ul style="list-style-type: none">> The totaliser is reset automatically with the value now set.	Menu EF: [rTo]
--	-------------------

10.3.5 Deactivation of the counter reset

<ul style="list-style-type: none">▶ Select [rTo] and set OFF.<ul style="list-style-type: none">> The totaliser is only reset after overflow.	Menu EF: [rTo]
---	-------------------

10.3.6 Counter reset using an external signal

<ul style="list-style-type: none">▶ Select [ou2] and set In.D.▶ Select [DIn2] and set counter reset signal:<ul style="list-style-type: none">- HIGH = reset for high signal- LOW = reset for low signal- +EDG = reset for rising edge- -EDG = reset for falling edge> The totaliser is reset to zero.	Menu OUT2: [ou2] [DIn2]
---	-------------------------------

10.4 Settings for temperature monitoring

10.4.1 Limit monitoring OUT1 or OUT2 / hysteresis function

<ul style="list-style-type: none">▶ Select [uni.T] and set the unit of measurement.▶ Select [SELx] and set TEMP.▶ Select [oux] and adjust the switching signal:<ul style="list-style-type: none">- Hno = hysteresis function / normally open- Hnc = hysteresis function / normally closed▶ Select [SPx] and set the value at which the output is set.▶ Select [rPx] and set the value at which the output is reset.	Menu OUTx: [SELx] [oux] [SPx] [rPx]
--	---

10.4.2 Limit monitoring OUT1 or OUT2 / window function

<ul style="list-style-type: none">▶ Select [uni.T] and set the unit of measurement.▶ Select [SELx] and set TEMP.▶ Select [oux] and adjust the switching signal:<ul style="list-style-type: none">- Fno = window function / normally open- Fnc = window function / normally closed▶ Select [FHx] and set the upper limit of the window section.▶ Select [FLx] and set the lower limit of the window sector.	Menu OUTx: [SELx] [oux] [FHx] [FLx]
---	---

10.4.3 Analogue signal temperature OUT2

<ul style="list-style-type: none">▶ Select [uni.T] and set the unit of measurement.▶ Select [SEL2] and set TEMP.▶ Select [ou2] and select analogue signal: I (4...20 mA)▶ Select [ASP2] and set the value at which 4 mA is provided.▶ Select [AEP2] and set the value at which 20 mA is provided.	Menu OUT2: [SEL2] [ou2] [ASP2] [AEP2]
---	---



10.5 User settings (optional)

10.5.1 Standard display

<ul style="list-style-type: none">▶ Select [diS.L] and set process value display:<ul style="list-style-type: none">- L1 = current process value for volumetric flow- L2.Temp = current process value for flow and temperature- L2.Totl = current process value for volumetric flow and totaliser- L3 = current process value for volumetric flow and temperature and current totaliser value▶ Select [diS.U] and set refresh rate of the display:<ul style="list-style-type: none">- d1 = high- d2 = medium- d3 = low▶ Select [diS.R] and set the orientation of the display: 0°, 90°, 180°, 270°▶ Select [diS.B] and set the brightness of the display: 25 %, 50 %, 75 %, 100 % or OFF (= energy-saving mode. The display is switched off in the operating mode. Error messages are displayed even if the display is deactivated. Display activation by pressing any key.)	Menu DIS: [diS.L] [diS.U] [diS.R] [diS.B]
---	---

UK

10.5.2 Standard unit of measurement for volumetric flow

<ul style="list-style-type: none">▶ Select [uni.F] and set unit of measurement for standard display (→ 8.1): l/min, m³/h, m/s, ft³/min, ft³/h, ft/s. <p> Set [uni.F] prior to configuring the outputs.</p> <p> The consumed quantity (meter reading) is automatically displayed in the unit of measurement providing the highest accuracy.</p>	Menu CFG: [uni.F]
---	----------------------

10.5.3 Standard unit of measurement for temperature

<ul style="list-style-type: none">▶ Select [uni.T] and set unit of measurement for standard display (→ 8.1): °C or °F. <p> Set [uni.T] prior to configuring the outputs.</p>	Menu CFG: [uni.T]
--	----------------------

10.5.4 Measured value damping

<ul style="list-style-type: none">▶ Select [dAP.F] and set damping constant in seconds (τ value 63 %).	Menu CFG: [dAP.F]
--	----------------------

10.5.5 Output logic

▶ Select [P-n] and set PnP or nPn.	Menu CFG: [P-n]
------------------------------------	--------------------

10.5.6 Low flow cut-off

▶ Select [LFC] and set limit, below which a current is evaluated as standstill.	Menu CFG: [LFC]
---	--------------------

10.5.7 Standard conditions

▶ Select [rEF.P] and set the standard pressure.	Menu CFG: [rEF.P] [rEF.T]
▶ Select [rEF.T] and set the standard temperature.	

10.5.8 System pressure

▶ Select [SySP] and set the system pressure.	Menu CFG: [SySP]
--	---------------------

10.5.9 Colour of the characters in the display

<ul style="list-style-type: none">▶ Select [coL.F] for volumetric flow or [coL.T] for temperature and set the colour of the characters for the process value in the standard display:<ul style="list-style-type: none">- bk/wh = permanently black/white- yellow = permanently yellow- green = permanently green- red = permanently red- r-cF = display colour red between the limits cFL...cFH, outside colour change to green- G-cF = display colour green between the limits cFL...cFH, outside colour change to red▶ Select [cFH.x] and [cFL.x] and set the limits for the colour window:<ul style="list-style-type: none">- cFH.F = upper limit for volumetric flow- cFL.F = lower limit value for volumetric flow- cFH.T = upper limit value for temperature- cFL.T = lower limit value for temperature▶ Select [coL.V] and set the colour of the characters for totaliser:<ul style="list-style-type: none">- bk/wh = permanently black/white- yellow = permanently yellow- green = permanently green- red = permanently red	Menu COLR: [coL.x] [cFH.x] [cFL.x] [coL.V]
--	--

UK

10.5.10 Switch-on /switch-off delay

<ul style="list-style-type: none">▶ Select [dSx] and set the delay for setting OUTx in seconds.▶ Select [drx] and set the delay for resetting OUTx in seconds.	Menu OUTx: [dSx] [drx]
---	------------------------------

10.5.11 Error behaviour of the outputs

<p>▶ Select [FOU1] and set error behaviour for output 1: switching output</p> <ul style="list-style-type: none">- On = output 1 switches ON in case of an error- OFF = output 1 switches OFF in case of an error- OU = output 1 switches irrespective of the error as defined with the parameters <p>▶ Select [FOU2] and set error behaviour for output 2: switching output</p> <ul style="list-style-type: none">- On = output 1 switches ON in case of an error- OFF = output 1 switches OFF in case of an error- OU = output 1 switches irrespective of the error as defined with the parameters <p>Analogue output</p> <ul style="list-style-type: none">- On = the analogue signal goes to the upper error value (→ 4.3)- OFF = the analogue value goes to the lower error value (→ 4.3)- OU = the analogue signal corresponds to the measured value <p> The parameter [FOUx] is not available if [ou] = Imp (consumed quantity monitoring) was selected. The pulses are provided independent of the fault.</p>	<p>Menu OUT1: [FOU1]</p> <p>Menu OUT2: [FOU2]</p>
---	---

10.5.12 Restore factory setting

<p>▶ Select [rES].</p> <p>▶ Briefly press [●].</p> <p>▶ Keep [▲] or [▼] pressed.</p> <p>> [----] is displayed.</p> <p>▶ Briefly press [●].</p> <p>> The device carries out a reboot.</p> <p> → 14 Factory setting. We recommend taking down your own settings in that table before carrying out a reset.</p>	<p>Menu EF: [rES]</p>
--	---------------------------

10.6 Diagnostic functions

10.6.1 Read min/max values

<p>▶ Select [Lo.x] or [Hi.x] to display the highest or lowest process value measured:</p> <ul style="list-style-type: none">- [Lo.F] = min. value of the flow volume measured in the process- [Hi.F] = max. value of the flow volume measured in the process- [Lo.T] = min. value of the temperature measured in the process- [Hi.T] = max. value of the temperature measured in the process <p>Delete memory:</p> <p>▶ Select [Lo.x] or [Hi.x].</p> <p>▶ Keep [▲] and [▼] pressed.</p> <p>> [----] is displayed.</p> <p>▶ Briefly press [●].</p> <p> It is recommended to delete the memories as soon as the unit operates under normal operating conditions for the first time.</p>	Menu MEM: [Lo.x] [Hi.x]
---	-------------------------------

UK

10.6.2 Simulation

<p>▶ Select [S.FLW] and set the flow value to be simulated.</p> <p>▶ Select [S.TMP] and set the temperature value to be simulated.</p> <p>▶ Select [S.Tim] and set the time of the simulation in minutes.</p> <p>▶ Select [S.On] and set the function:</p> <ul style="list-style-type: none">- On = The simulation starts. The values are simulated for the time set with [S.Tim]. Cancel by pressing any button.- OFF = The simulation is not active.	Menu SIM: [S.FLW] [S.TMP] [S.Tim] [S.On]
---	--

11 Operation

The process values to be displayed permanently can be preset (→ 10.5.1 Standard display). A standard unit measurement can be defined for the flow rate measurement and the temperature measurement (→ 10.5.2 and → 10.5.3).

In addition to the preset standard display, the display can be changed by pressing [▲] or [▼] → 8.1 Process value display (RUN).

12 Error correction

The unit has many self-diagnostic options. It monitors itself automatically during operation.

Warnings and error states are displayed, even when the display is switched off. Error indications are also available via IO-Link.

The status signals are classified according to NAMUR recommendation NE107.

If several diagnostic events occur simultaneously, only the diagnostic message of the result with the highest priority is displayed.

If one process value fails, the other process values continue to be available.



Additional diagnostic functions are available via IO-Link → IODD interface description at www.ifm.com

Process value line	Title line	Status LED	Type	Description	Output response	Error correction
ERROR	ERROR	--	⊗	Unit faulty / malfunction	FOU	Replace device.
Off	Off	--	⊗	Supply voltage too low	Off	Check the supply voltage. Change [diS.B] setting (→ 10.5.1).
PArA	Parameter Error	---	⊗	Parameter setting outside the valid range	FOU	Repeat parameter setting.
ERROR	Flow Error	---	⊗	Error in flow measurement	FOU	Check flow measurement. Replace device.

Process value line	Title line	Status LED	Type	Description	Output response	Error correction
ERROR	Temp Error	---	⊗	Error in temperature measurement	FOU	Check temperature measurement. Replace device.
cr.OL	Critical over limit	---	⊗	Detection zone* exceeded	FOU	Check flow range / temperature range.
cr.UL	Critical under limit	---	⊗	Detection zone* not reached	FOU	Check temperature range.
---	Short circuit OUT1/OUT2	OUT1 ✖ OUT2 ✖	⚠	Short circuit OUT1 and OUT2	---	Check switching outputs OUT1 and OUT2 for short-circuit or excessive current.
---	Short circuit OUT1	OUT1 ✖	⚠	Short circuit OUT1	---	Check switching output OUT1 for short-circuit or excessive current.
---	Short circuit OUT2	OUT2 ✖	⚠	Short circuit OUT2	---	Check switching output OUT2 for short-circuit or excessive current.
OL	Over limit	---	⚠	Detection zone* exceeded.	OU	Check flow range / temperature range.
UL	Under limit	---	⚠	Detection zone* not reached	OU	Check flow range / temperature range.
Lock via key	---	---	⚠	Setting buttons on the unit locked, parameter change rejected	OU	Unlock unit → 10.1.3
Lock via communication	---	---	⚠	Parameter setting locked via push-buttons, parameter setting is active via IO-Link communication	OU	Finish parameter setting via IO-Link communication.

UK

Process value line	Title line	Status LED	Type	Description	Output response	Error correction
Lock via system	---	---		Setting buttons locked via parameter software, parameter change rejected	OU	Unlock the unit via IO-Link interface using the parameter setting software.
IO-Link	IO-Link flash	OUT1 OUT2		IO-Link function for optical identification of the unit active	OU	Deactivate IO-Link function.

* Detection zone → 4.3, Figure 1.

Error In the event of an error, the outputs react according to the setting under [FOU1] and [FOU2] (→ 10.5.11).

Warning

LED flashes

LED flashes quickly

13 Maintenance, repair and disposal

As a rule, no measures for maintenance are necessary.

- ▶ Define regular calibration intervals according to the process requirements.
Recommendation: every 12 months.

Only the manufacturer is allowed to repair the unit.

- ▶ After use dispose of the unit in an environmentally friendly way in accordance with the applicable national regulations.

14 Factory setting

Menu	Parameter	Factory setting	User setting
EF	rTo	OFF	
OUT1	SEL1	FLOW	
	ou1	Hno	
	SP1 / FH1	20 %	
	rP1 / FL1	19 %	
	ImPS1	0.0001 m ³	
	ImPR1	YES	
	dS1	0	
	dr1	0	
	FOU1	OFF	
OUT2	SEL2	FLOW	
	ou2	I	
	ASP2	0 %	
	AEP2	100 %	
	SP2 / FH2	40 %	
	rP2 / FL2	39 %	
	ImPS2	0.0001 m ³	
	ImPR2	YES	
	DIn2	+EDG	
	dS2	0	
	dr2	0	
	FOU2	OFF	

UK

Menu	Parameter	Factory setting	User setting
CFG	uni.F	m ³ /h	
	uni.T	°C	
	dAP.F	0,6 s	
	P-n	PnP	
	LFC	0.1 m ³ /h	
	rEF.T	15 °C	
	SySP	6 bar	
DIS	diS.L	L3	
	diS.U	d3	
	diS.R	0	
	diS.B	75	
COLR	coL.F	bk/wh	
	coL.T	bk/wh	
	coL.V	bk/wh	

The percentage values refer to the final value of the measuring range.