



CE

Operating instructions
Oil humidity sensor
LDH100

UK

706104 / 02 03 / 2022

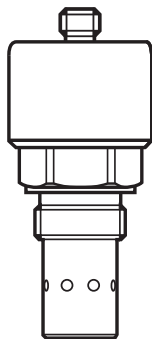

Contents

1 Preliminary note.....	3
1.1 Symbols used.....	3
2 Safety instructions	3
3 Functions and features	4
3.1 Applications	4
4 Function.....	5
4.1 Measuring principle	5
4.1.1 Temperature measurement	5
4.1.2 Humidity measurement.....	5
4.1.3 Relative and absolute humidity.....	5
4.2 Processing of the measured signals.....	6
5 Installation.....	7
5.1 Typical measuring system	7
5.2 Installation location / environment	8
5.3 Installation procedure	10
6 Electrical connection.....	11
7 Operation.....	12
7.1 Reference values for the assessment of the measured values.....	12
8 Maintenance, repair, disposal.....	13

1 Preliminary note

1.1 Symbols used

► Instructions

→ Cross-reference



Important note

Non-compliance can result in malfunction or interference.



Information

Supplementary note.

2 Safety instructions

- The device described is a subcomponent for integration into a system.
 - The manufacturer of the system is responsible for the safety of the system.
 - The system manufacturer undertakes to perform a risk assessment and to create a documentation in accordance with legal and normative requirements to be provided to the operator and user of the system. This documentation must contain all necessary information and safety instructions for the operator, the user and, if applicable, for any service personnel authorised by the manufacturer of the system.
- Read this document before setting up the product and keep it during the entire service life.
- The product must be suitable for the corresponding applications and environmental conditions without any restrictions.
- Only use the product for its intended purpose (→ Functions and features).
- Only use the product for permissible media (→ Technical data).
- If the operating instructions or the technical data are not adhered to, personal injury and/or damage to property may occur.
- The manufacturer assumes no liability or warranty for any consequences caused by tampering with the product or incorrect use by the operator.
- Installation, electrical connection, set-up, operation and maintenance of the unit must be carried out by qualified personnel authorised by the machine operator.
- Protect units and cables against damage.
- The unit complies with the standard EN 61000-6-4. In domestic areas (EN 61000-6-3) the unit must be installed in closed metal tanks / pipes.

3 Functions and features

The unit continuously measures the relative water content and the temperature of hydraulics and lubricants.

3.1 Applications

The unit is suitable for mineral oils, synthetic esters and bio oils. It covers the following measuring ranges:

- Relative humidity: 0...100 %
- Temperature: -20...+120 °C

4 Function

4.1 Measuring principle

4.1.1 Temperature measurement

The unit measures the oil temperature by means of a platinum measuring resistor (Pt1000).



Since the sensor is located directly in the oil, the conductivity of the surrounding medium must not exceed a value of 3 ms/m. Too high a conductivity deteriorates the measurement accuracy; the sensor will, however, not be damaged.

4.1.2 Humidity measurement

The unit measures the relative water content by means of a capacitive transducer. The oil's water saturation level is indicated in the range of 0...100 %:

0 %	dry oil
100 %	oil is fully saturated with water

(→ 7.1 Reference values for the assessment of the measured values)

4.1.3 Relative and absolute humidity

The relative humidity (φ) is the ratio of the amount of dissolved water actually contained in the oil (ρ_w) and the maximum possible amount of the saturation limit ($\rho_{w, \max}$):

$$\varphi = \frac{\rho_w}{\rho_{w, \max}} \times 100 \%$$

ρ_w	Absolute humidity or the amount of dissolved water actually contained in the oil. Is typically indicated in ppm (parts per million).
$\rho_{w, \max}$	Absolute humidity at the saturation limit (in ppm).

UK

In contrast, the absolute water content is not a physically measured value. It is determined on the basis of the relative humidity and the saturation limit using the formula below.

$$\rho_w = \frac{\varphi \times \rho_{w, \max}}{100 \%}$$

The saturation limit $\rho_{w, \max}$ depends first of all on the type of oil. For further information about the type of oil please contact the manufacturer of the oil.

Secondly the saturation limit is very dependant on the temperature. Therefore the relative humidity changes with the temperature. The same applies when the absolute humidity remains constant. Usually oils absorb more water with increasing temperature.

4.2 Processing of the measured signals

The unit detects the measured values continuously and outputs them as analogue signals. It has two 4...20 mA current outputs with the following fixed measurement limits:

	Measured value	Output signal
OUT 1	-20...120 °C (oil temperature)	4...20 mA linear
OUT 2	0...100 % rel. humidity	4...20 mA linear

5 Installation

5.1 Typical measuring system

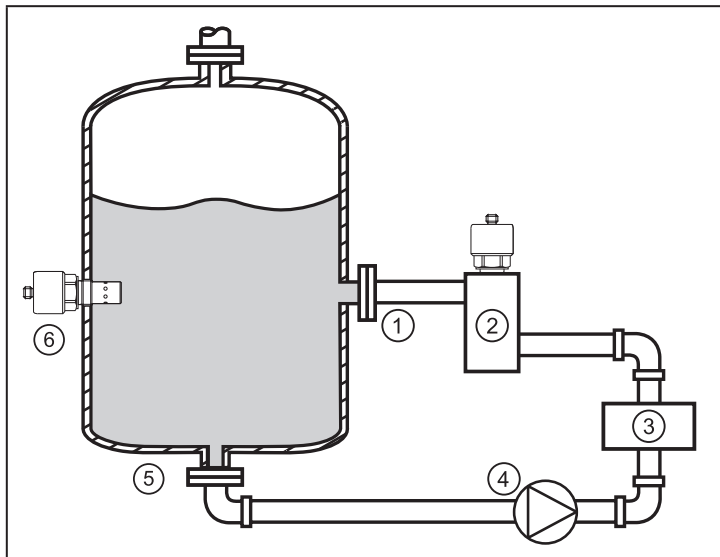

- 1: Connection of the return pipe
- 2: Pipe adapter with unit
- 3: Consumer
- 4: Pump
- 5: Connection of the rinse pipe
- 6: Unit directly screwed into the tank wall

5.2 Installation location / environment

- Install the unit according to the specification (max. 50 bar).
- Do not install the unit in the direct vicinity of hot components (e.g. motors) to avoid thermal effects.
- The installation position shall be representative for the condition of the oil.
- The unit shall be installed at a point where the medium is sufficiently mixed.
- The probe must be completely covered by the measured medium and be below the minimum oil level in any operating situation. Please note in particular the level variations in the tank or a possible tilted position (fig. 2 on the next page).
- Preferred location in hydraulic circuits: in the tank close to the return pipe.
- In case of gears with forced rinsing the unit may also be installed in the rinse pipe.
- If the unit is installed in a return pipe or a rinse pipe: make sure that the pipe does not run dry in any operating situation.
- If the oil in the tank is not sufficiently mixed, it is possible that free water settles on the bottom. In this case two layers form: the upper one consists of oil, the lower one of free water. Should the measurements be made in the upper level, the horizontal installation according to number 6 in figure 1 on the next page is recommended. Should the measurement be made in the lower layer, the vertical installation according to number 5 is recommended.
- When the sensor is installed vertically into the bottom make sure that the sensor is above the decoction level. Otherwise measurement may be affected by build-up of dirt.
- The max. installation angle (fig. 2 on the next page, position number 7) depends on the installation height and the min. level. The probe must again be completely covered by the measured medium and be below the minimum oil level in any operating situation.

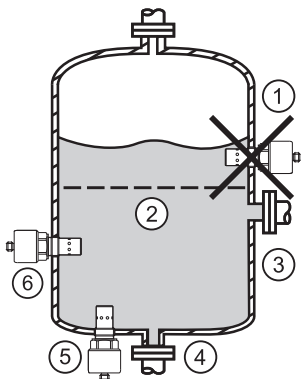
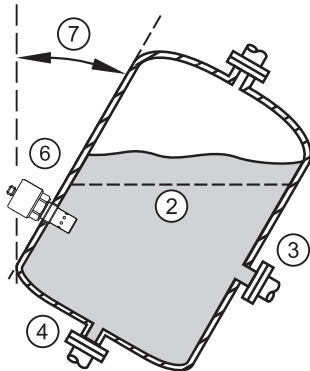
Fig. 1**Fig. 2**

- 1: Wrong installation position
- 2: Minimum oil level in the tank
- 3: Connection of the return pipe
- 4: Connection of the rinse pipe
- 5: Sensor vertically installed in the bottom
- 6: Horizontally installed sensor
- 7: Installation angle

5.3 Installation procedure



- ▶ Ensure that the system is free of pressure during installation.
- ▶ Ensure that no media can leak at the mounting location during installation.
- ▶ The sealing area on the process connection must be flush and free of unevenness and dirt. Max. roughness value $R_{\max} = 16$.
- ▶ Check profile sealing ring (A) for correct position (in a groove).
- ▶ Screw the unit into the G $\frac{3}{4}$ process connection (B) and tighten firmly. Max. tightening torque $45 \text{ Nm} \pm 4.5 \text{ Nm}$.

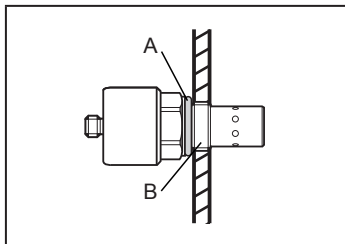

The unit can also be installed in the pipe by means of a pipe adapter. The following accessories are available:

Adapter block to install the sensor in a pipe; pipe connections $\frac{3}{4}$ "; max. pressure $p_{\max} = 50 \text{ bar}$	Order number E43400
--	---------------------

6 Electrical connection



- The unit must be connected by a qualified electrician.
- The national and international regulations for the installation of electrical equipment must be adhered to.
- Voltage supply to SELV, PELV.
- Use a screened sensor cable.

- ▶ Disconnect power.
- ▶ Connect the unit as follows:

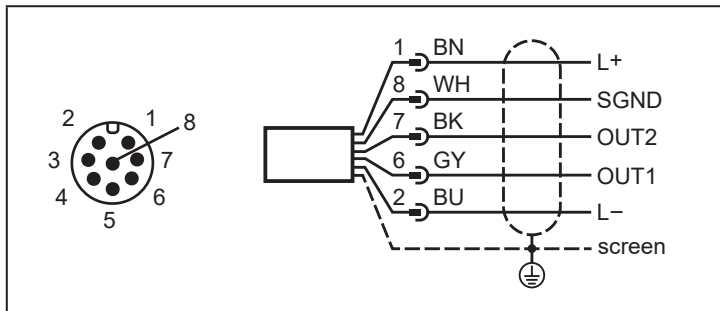

The following sockets are available as accessories:

8-pole, screened M12 socket; straight	E80021
8-pole, screened M12 socket; angled	E80022

7 Operation

When the supply voltage has been applied, the unit is in the operating mode. It performs its evaluation function and provides analogue signals.

- ▶ Check the proper functioning of the sensor.
- ▶ Check analogue current outputs (the current must not be below $4 \text{ mA} \pm 0.2 \text{ mA}$ and not above $20 \text{ mA} \pm 0.2 \text{ mA}$).

7.1 Reference values for the assessment of the measured values

0...40 % r. h.	no action required (oil is dry)
40...60 % r. h.	watch the oil / installation
60...100 % r. h.	take action
General conditions for reference values	air temperature 20...25 °C air humidity approx. 20...70 % oil temperature approx. 45 °C

r.h. = relative humidity

8 Maintenance, repair, disposal

- ▶ From time to time check the sensor for build-up and damage. If there are any deposits, carefully clean it by rinsing with isopropanol or fresh oil. After cleaning the unit must dry for a few minutes before it delivers correct measurements. In case of damage replace the unit.
- ▶ It is not possible to repair the unit.
- ▶ After use dispose of the unit in an environmentally friendly way in accordance with the applicable national regulations.
- ▶ In case of returns ensure that the unit is free from soiling, especially of dangerous and toxic substances. For transport only use appropriate packaging to avoid damage of the unit.